

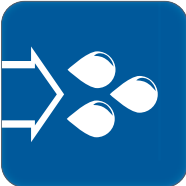

USER MANUAL

HIGH PRESSURE WATER PUMPS



HPW 90
HPW 130
HPW 180
HPW 200

HPW 220
HPW 300
HPW 320
HPW 360

HPW 420
HPW 460
HPW 520
HPW 800

HPW 1000
HPW 1200
HPW 1600

Download PDF version from www.Dynaset.com/manuals

Keycode: DM4YRG



Congratulations!





You have just purchased DYNASET hydraulic equipment!

The equipment allows you to maximize the productivity and efficiency of your mobile machine. Read this User Manual before using your new equipment. It contains important information that will help you to take the full advance of the technical features available in your equipment.

Please contact us for any feedback you might have on our products. Your feedback is important to us for improving our products and customer service.

We are constantly developing and releasing new innovations. Please visit on our website and social media channels for the latest news and updates.

www.dynaset.com
info@dynaset.com

 www.facebook.com/dynaset
 www.youtube.com/dynasetoy
 www.twitter.com/Dynaset_ofcl
 www.instagram.com/dynaset_official

Subscribe to our newsletter. Follow the QR code!





1. GENERAL	7
1.1. PRODUCT INFORMATION.....	7
1.2. PRODUCT IDENTIFICATION KEY.....	8
1.3. TYPE PLATE.....	9
1.4. HPW PUMP LINE-UP.....	10
1.5. MAIN COMPONENTS OF HPW PUMP.....	11
2. SAFETY	13
2.1. SAFETY PRECAUTIONS.....	13
2.2. SAFETY EQUIPMENT.....	13
2.3. OPERATING SAFETY.....	14
2.4. MAINTENANCE SAFETY.....	15
2.5. WARNING LABELS.....	15
3. OPERATING PRINCIPLES	17
3.1. OPERATING DESCRIPTION.....	17
3.2. HYDRAULIC CONNECTION IN PARALLEL AND SERIES.....	19
3.3. PUMPING FLUID CONNECTION IN PARALLEL AND SERIES.....	20
4. INSTALLATION	21
4.1. BEFORE INSTALLATION.....	21
4.1.1. HYDRAULIC SYSTEM OF A BASE MACHINE.....	21
4.1.2. DYNASET VALVES.....	28
4.2. INSTALLING DYNASET HYDRAULIC PRODUCT.....	29
4.2.1. PLACING DYNASET HYDRAULIC PRODUCT.....	29
4.2.2. INSTALLING DYNASET VALVES.....	29
4.2.3. CONNECTING HYDRAULIC HOSES.....	30
4.2.4. HYDRAULIC FLUIDS.....	31
4.3. INSTALLING HPW-PUMP.....	31
4.3.1. MAXIMUM INCLINATIONS.....	31
4.3.2. CONNECTION TO THE PUMPING FLUID INTAKE.....	32
4.3.3. CONNECTION TO THE PUMPING FLUID OUTPUT.....	33



HIGH PRESSURE WATER PUMPS

TABLE OF CONTENTS

5. OPERATION	35
5.1. STARTING THE HPW PUMP.....	35
5.2. ADJUSTING FLOW RATE AND PRESSURE OF PUMPING FLUID.....	36
5.3. PUMPING FLUIDS.....	37
5.4. WORKING IN COLD TEMPERATURES.....	38
5.5. STOPPING THE HPW PUMP.....	38
6. MAINTENANCE	39
6.1. MAINTENANCE INTERVAL.....	39
6.2. HYDRAULIC FLUIDS.....	40
6.3. CLEANING THE HPW PUMP.....	40
6.4. REPLACING WATER VALVES.....	41
6.5. REPLACING PUMP SEALS.....	43
6.6. BOLT TIGHTENING TORQUES.....	49
6.7. TROUBLESHOOTING.....	50
7. MANUFACTURER'S LIMITED WARRANTY	53
8. PRODUCT DISPOSAL	55
9. DECLARATION OF CONFORMITY	57
10. TECHNICAL SPECIFICATIONS	59

Picture 1: Identification key for HPW pumps	8
Picture 2: Type plate	9
Picture 3: HPW pump line-up.....	10
Picture 4: Main components of HPW pump.....	11
Picture 5: Operating description of HPW pump 1	17
Picture 6: Operating description of HPW pump 2	18
Picture 7: Relation of pumping fluid's flow rate and pressure.....	19
Picture 8: HPW hydraulic line connection in parallel	19
Picture 9: HPW hydraulic line connection in series	20
Picture 10: Open centre hydraulic system with Load Sensing variable displacement pump	22
Picture 11: Connection figure for open centre hydraulic system with Load Sensing variable displacement pump.....	23
Picture 12: Closed centre hydraulic system with Load Sensing variable displacement pump	24
Picture 13: Connection figure for closed centre hydraulic system with Load Sensing variable displacement pump.....	25
Picture 14: Hydraulic system with fixed displacement pump	26
Picture 15: Connection figure for hydraulic system with fixed displacement pump	27
Picture 16: Load sensing valve LSV	28
Picture 17: Priority valve PV-SAE	28
Picture 18: Placing HPW high pressure water pumps	29
Picture 19: Connecting hydraulic hoses	30
Picture 20: Base machine's pumps	30
Picture 21: Return line connection	31
Picture 22: Leakage detecting holes.....	31
Picture 23: Connection to the pumping fluid intake	32
Picture 24: Installation into pumping fluid line	32
Picture 25: Connection to the pumping fluid output	33
Picture 26: Starting the HPW pump	35
Picture 27: HPW pump with water pressure unloader valve.....	36
Picture 28: HPW pump without water pressure unloader valve.....	36
Picture 29: Stopping the HPW pump.....	38
Picture 30: Stopping procedure of the HPW pump	38

1. GENERAL

This manual contains general information about assembly, installation, operation and maintenance of DYNASET HPW high pressure water pumps.

 **ATTENTION!**

Read this user manual before installation, use or maintenance of the HPW pump to ensure proper handling, operation and maintenance right from the beginning. Pay attention to warnings and safety instructions. READ CHAPTER "2. SAFETY" for more information.

1.1. PRODUCT INFORMATION

DYNASET HPW pump converts the hydraulic oil flow of a base machine into high pressure water. HPW pumps are used for pumping water and other fluids depending on a model. The power of the pump is defined by flow rate and pressure. Actuating power is supplied from the hydraulic system of the base machine or other hydraulic installation. Pumping fluid can be taken from reservoir or pressurized supply network. Water can also be taken from natural source such as lake or river.

The relationship between hydraulic oil flow and pressure to pumping fluid flow and pressure is linear. HPW pumps can be safely operated in power range of 0-100%.

Most of HPW pumps are self-priming. READ CHAPTER "10. TECHNICAL SPECIFICATIONS" for specific characteristics of any pump.

 **NOTE!**

The design of HPW pump is protected with an international patent.

1.2. PRODUCT IDENTIFICATION KEY

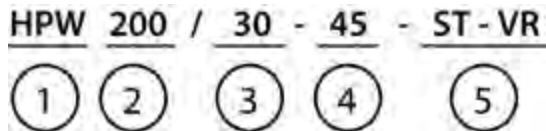

Picture 1: Identification key for HPW pumps

- 1.Product Group HPW Hydraulic Power Washers
- 2.Maximum water pressure that HPW pump can produce (40-1600 bar).
- 3.Maximum water flow or other pumping fluid flow that moves through HPW pump (15-300l/min).
- 4.Maximum hydraulic oil flow from the base machine required to run HPW pump (8-350 l/min).
- 5.Options (listed below)

Water unloader valve (ST/PA)

The unloader valve directs water flow into bypass when the high pressure water output is closed or not needed. In HPW200 pumps water unloader valve is ST-model, other HPW pumps has PA-model.

Flow limiter (VR)

Limits the oil flow from the base machine. This function allows to use the HPW pump with partial load instead of maximum flow.

Pressure reducing valve (PA)

Reduces the oil pressure from the base machine. This function gives possibilities to drive HPW pump with partial load instead of maximum pressure.

Load Sensing (LS)

Load Sensing on PT-flange. Senses and provides only the pressure and flow required by the HPW pump. This function saves significantly energy and customer's expenses preventing excessive part wear in long term.

Marine (M)

For marine use. Pipes of unloader valve and all bolts are made of stainless steel.

Center body and heads stainless steel (AIS)

The center body and the heads of the pump are made of stainless steel.

Center body and heads aluminium bronze (AB)

The center body and the heads of the pump are made of aluminium bronze.

Under water use (SUB)

For under water use. The center body and the heads are made of stainless steel or aluminium. Plugs are made of stainless steel, bolts are made of stainless steel or with special coating.

Seals for hot fluids and specific chemicals (HOT)

Seals are made to tolerate hot fluids and some specific chemicals.

Load Sensing Control (LSC)

Automatic Load Sensing Control on PT-flange. It is useful when hydraulic flow and pressure is occasionally needed. Off-state drives main hydraulic pump via LS-line to 0° angle and on-state drives hydraulic pump to full angle, producing maximum oil flow to the HPW pump. This function saves significantly energy and customer's expenses preventing excessive part wear in long term.

1.3. TYPE PLATE



Picture 2: Type plate

The products type plate shows the following information.

1. Product identification key
2. Product code
3. Serial number
4. Maximum hydraulic flow
5. Maximum hydraulic pressure
6. Production month / year
7. Output water flow rate and pressure.
8. Manufacturer's contact information

1.4. HPW PUMP LINE-UP

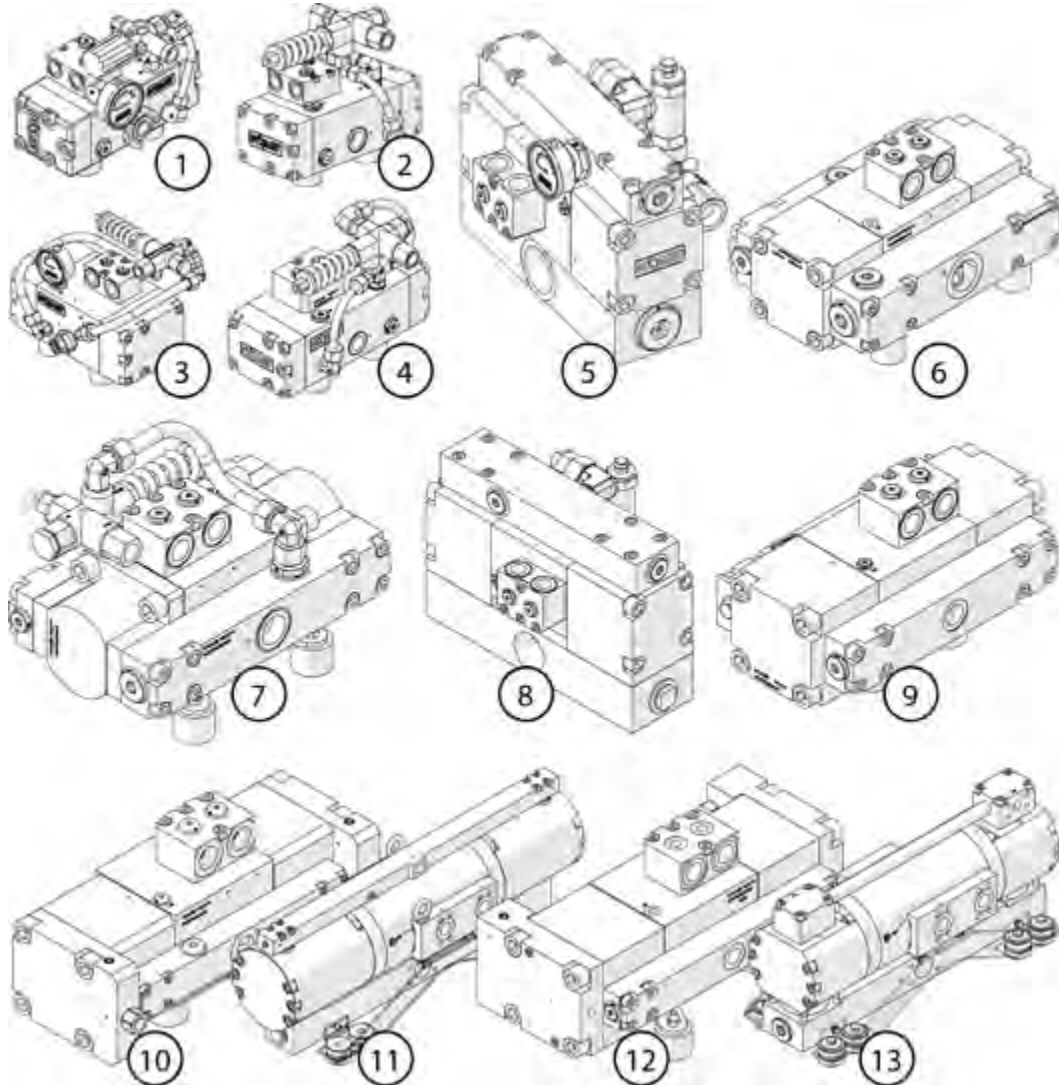

Picture 3: HPW pump line-up

- | | |
|----------------------|--------------|
| 1. HPW 200 | 8. HPW 130 |
| 2. HPW 420 | 9. HPW 800 |
| 3. HPW 220 | 10. HPW 1000 |
| 4. HPW 520 | 11. HPW 1200 |
| 5. HPW 90 | 12. HPW 1600 |
| 6. HPW 180 | 13. HPW 300 |
| 7. HPW 460 / HPW 320 | |

1.5. MAIN COMPONENTS OF HPW PUMP

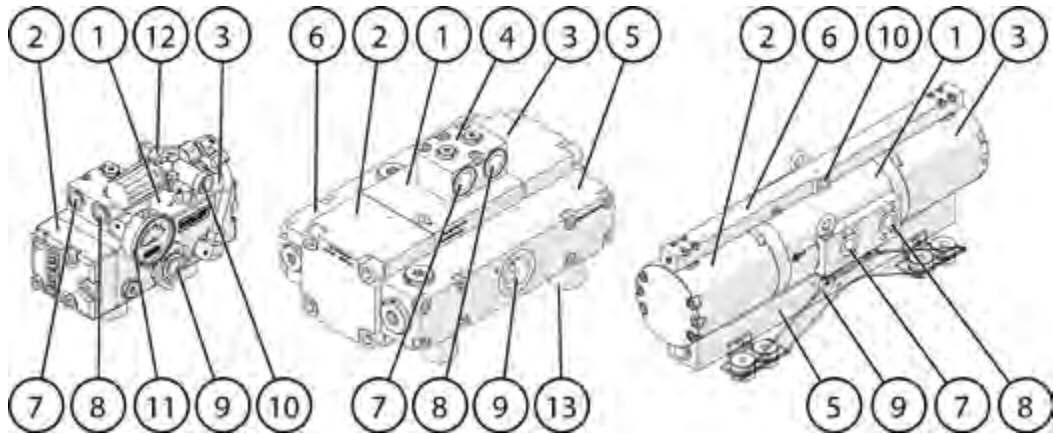

Picture 4: Main components of HPW pump

- | | |
|-----------------------|--------------------------------|
| 1. Body | 7. Hydraulic pressure line (P) |
| 2. Head right | 8. Hydraulic tank line (T) |
| 3. Head left | 9. Pumping fluid intake (S) |
| 4. PT-flange | 10. Pumping fluid outlet (WP) |
| 5. Suction manifold | 11. Pressure gauge |
| 6. Discharge manifold | 12. Water unloader valve |

2. SAFETY

2.1. SAFETY PRECAUTIONS

 **ATTENTION!**



Operators and maintenance personnel must always comply with local safety regulations and precautions in order to close out the possibility of damages and accidents.

The pressure in both hydraulic oil and water circuits of HPW pump is considerably high. Keep the condition of your equipment and hydraulic system under constant observation.

 **WARNING**

HIGH PRESSURE WATER AND OIL!

Can cause severe injuries.
Always wear appropriate clothing
and safety equipment.



Couplings, valves and hoses need to be kept tight and clean to avoid possible leakages. Leaks in the hydraulic system must be repaired immediately to avoid injuries caused by high pressure blowouts.

In order to avoid accidents, it is not allowed to clean or inspect HPW unit when hydraulic fluid circuit is pressurized. Prior to any cleaning, inspection and service, hydraulic system of your base machine must be stopped and all hydraulic fluid circuits must be depressurized.

Prevent nozzles, water circuit and pipeline from freezing. Draining and air flushing of the water circuit have to be performed before ambient temperature reaches 0°C or lower.

2.2. SAFETY EQUIPMENT

Always wear appropriate clothing and safety equipment such as safety goggles, safety shoes and ear protection when operating the HPW pump.



2.3. OPERATING SAFETY

When operating the HPW pump, beware of the unit parts warmed by hot hydraulic oil.

 **WARNING**

RISK OF BURNS!

The unit parts and hydraulic oil can be hotter than 80 °C!

Wear personal safety equipment!



Never aim high pressure water at a person.

 **WARNING**

HIGH PRESSURE WATER!

Never aim high pressure water at a person. This can cause severe injuries.



 **ATTENTION!**

Do not exceed the maximum pressure, temperature or load.

2.4. MAINTENANCE SAFETY

 **ATTENTION**

Installation and service of hydraulic equipment must be performed by qualified and experienced personnel only.

 **NOTE!**

When carrying out any maintenance to HPW pump keep the components of the system clean. This is to ensure safe, reliable and longlife operation of your equipment.

Hydraulic system of the base machine should be maintained according to the service program.

2.5. WARNING LABELS

Product recipient is obligated to place warning labels on the DYNASET product. Attach labels to visible and appropriate place onto or close to DYNASET product where it's easily seen. Clean surface with solvent detergent before attaching labels.



LUE
KÄYTTÖOHJEET.



VARO
KORKEAPAINESIA
ROISKEITA.



ESTÄ
JÄÄTYMINEN.



KÄYTÄ
KUULONSUOJAIMIA
JA SUOJALASEJA.

3. OPERATING PRINCIPLES

3.1. OPERATING DESCRIPTION

The patented HPW-pump utilizes the reciprocal motion of the hydraulic piston.

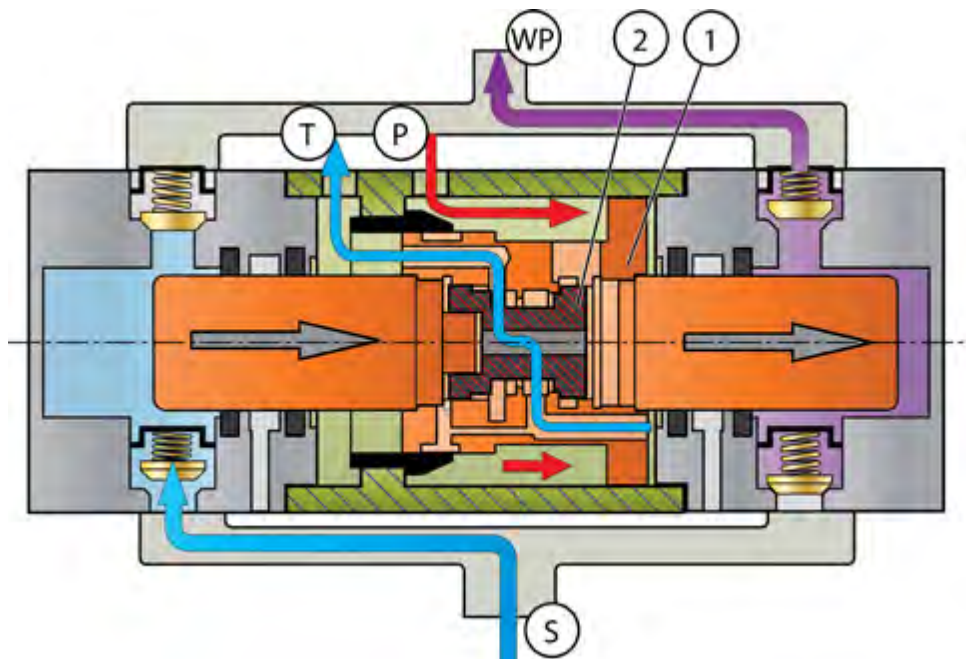

Picture 5: Operating description of HPW pump 1

HPW-pump is driven by hydraulic flow through the hydraulic ports (P) and (T). Hydraulic flow moves the piston assembly (1) into its extreme position. After extreme position reached, reversal valve (2) inside the piston assembly changes the direction of hydraulic flow and the piston assembly starts to move into the opposite direction.

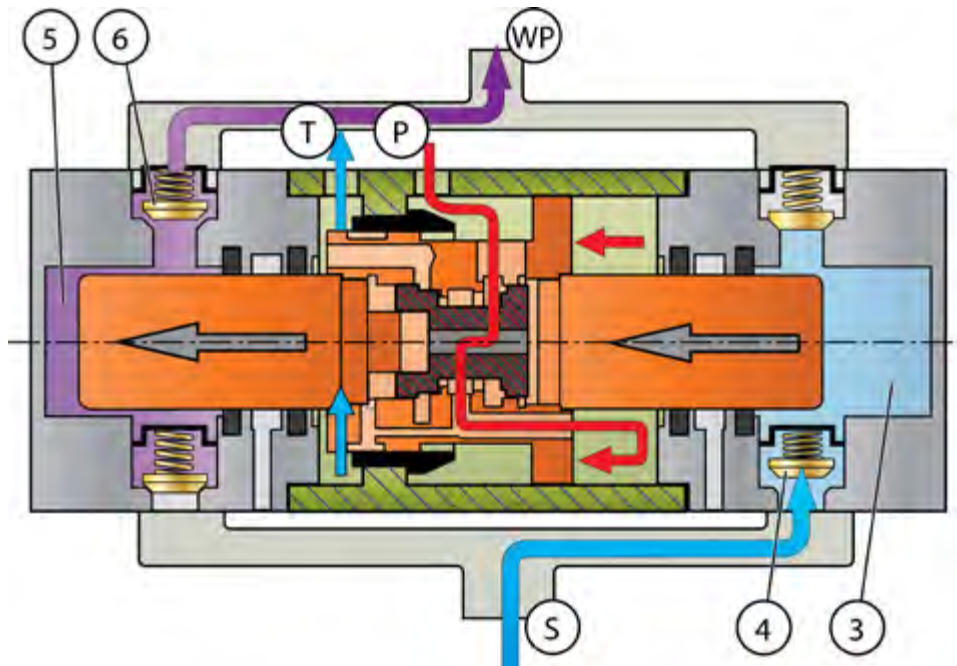

Picture 6: Operating description of HPW pump 2

Move of the piston assembly creates pressure and suction. Pump self-priming from water supply line (S) and generates pressure into pressure line (WP). When piston assembly moves away from head it creates underpressure (3) and water (or other pumping fluid) is sucked through intake valve (4) into head.

When water piston moves towards the head, it creates pressure (5) and water is pushed through pressure valve (6) into pumping fluid outlet (WP).

! NOTE !

Most of HPW-pumps are self-priming. Specific characteristics of any pump can be verified according to parameters, READ CHAPTER „10. TECHNICAL SPECIFICATIONS“.

The relationship between hydraulic oil flow and pressure to pumping fluid flow and pressure is linear.

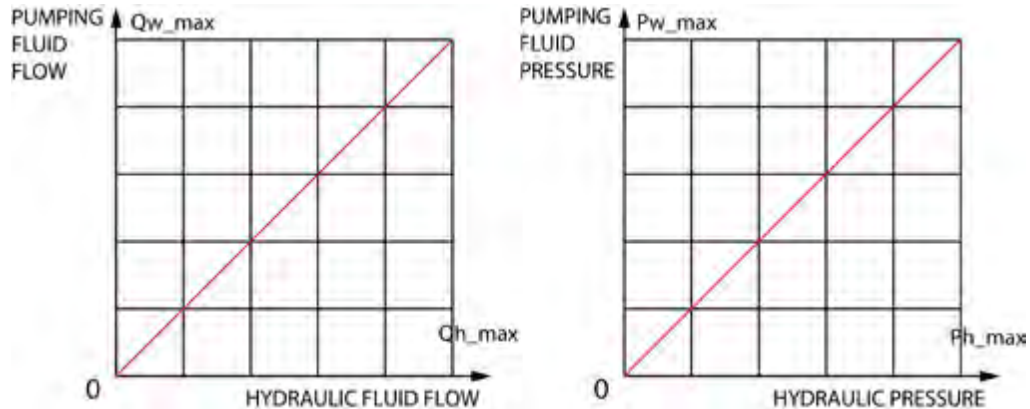

Picture 7: Relation of pumping fluid's flow rate and pressure.

HPW pumps can be safely operated in power range of 0-100%.

3.2. HYDRAULIC CONNECTION IN PARALLEL AND SERIES

Hydraulic lines of multiple HPW pumps can be connected in parallel to get maximum output pressure and double the output flow. Use flow controller valves when high pressure water pumps are connected in parallel.

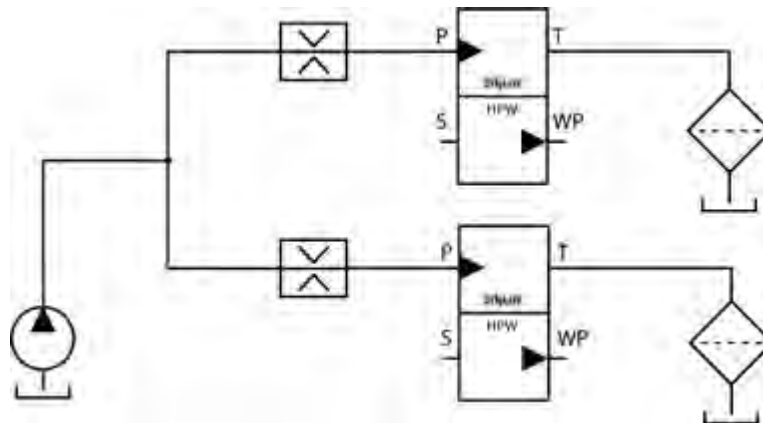

Picture 8: HPW hydraulic line connection in parallel

! NOTE!

Hydraulic oil flow required in parallel connection is the maximum hydraulic oil flow of the HPW pump multiplied by the count of the pumps.

Hydraulic lines of multiple HPW pumps can be connectec in series to get higher output flow in small hydraulic flow. Maximum output pressure is divided by the count of the pumps in series connction.

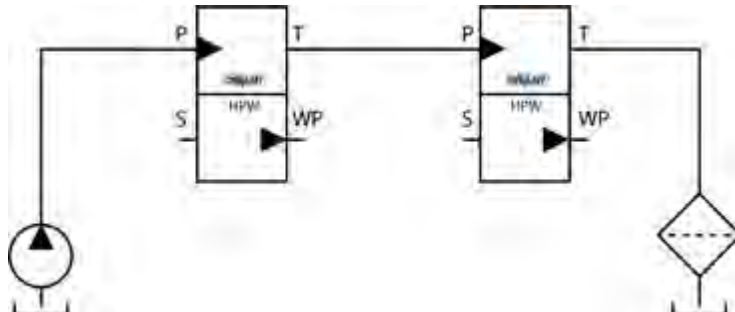

Picture 9: HPW hydraulic line connection in series

3.3. PUMPING FLUID CONNECTION IN PARALLEL AND SERIES

Pumping fluid lines of multiple HPW pumps can also be connected in parallel or in series.

! NOTE!

If pumps with different pressure level is used, the pump which has lower nominal pressure, must be protected with for example check valve.

4. INSTALLATION

4.1. BEFORE INSTALLATION

 **ATTENTION!**

Read the instructions before installing the DYNASET product!

4.1.1. HYDRAULIC SYSTEM OF A BASE MACHINE

Base machines have different type of hydraulic systems. Most common hydraulic systems in mobile machinery are:

- Open centre hydraulic system with Load Sensing variable displacement pump
- Closed centre hydraulic system with Load Sensing variable displacement pump
- Hydraulic system with fixed displacement pump

Before installing the DYNASET product, find out the type of the hydraulic system of your machine.



If you are unsure of the hydraulic system, please contact the base machine manufacturer.

Next three paragraphs describe the hydraulic systems in more detail.

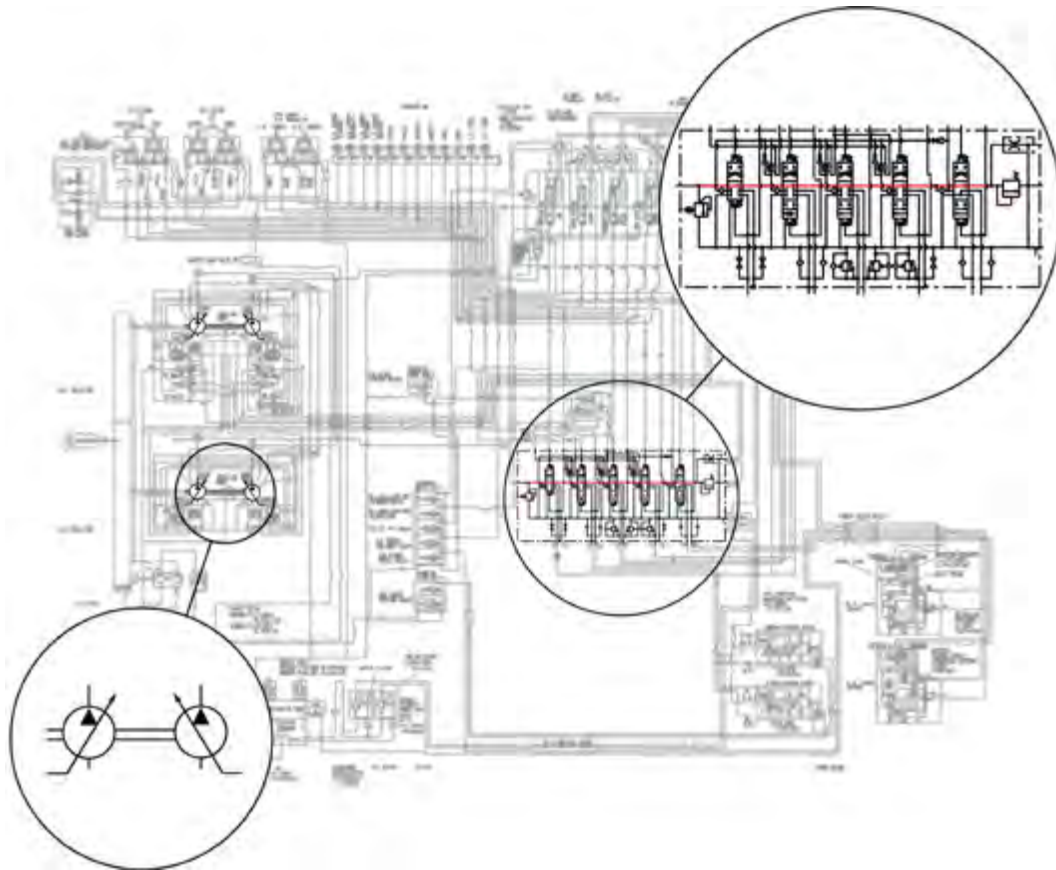
OPEN CENTRE HYDRAULIC SYSTEM WITH LOAD SENSING VARIABLE DISPLACEMENT PUMP

Picture 10: OpencentrehydraulicsystemwithLoadSensingvariabledisplacementpump

In open centre hydraulic system the flow is returned to tank through the control valves open centre; that is, when the control valve is centered. It provides an open return path to tank and the fluid is not pumped into a high pressure. In Load Sensing variable-displacement pump, the flow rate and output pressure adjusts automatically based on the load of the hydraulic system.

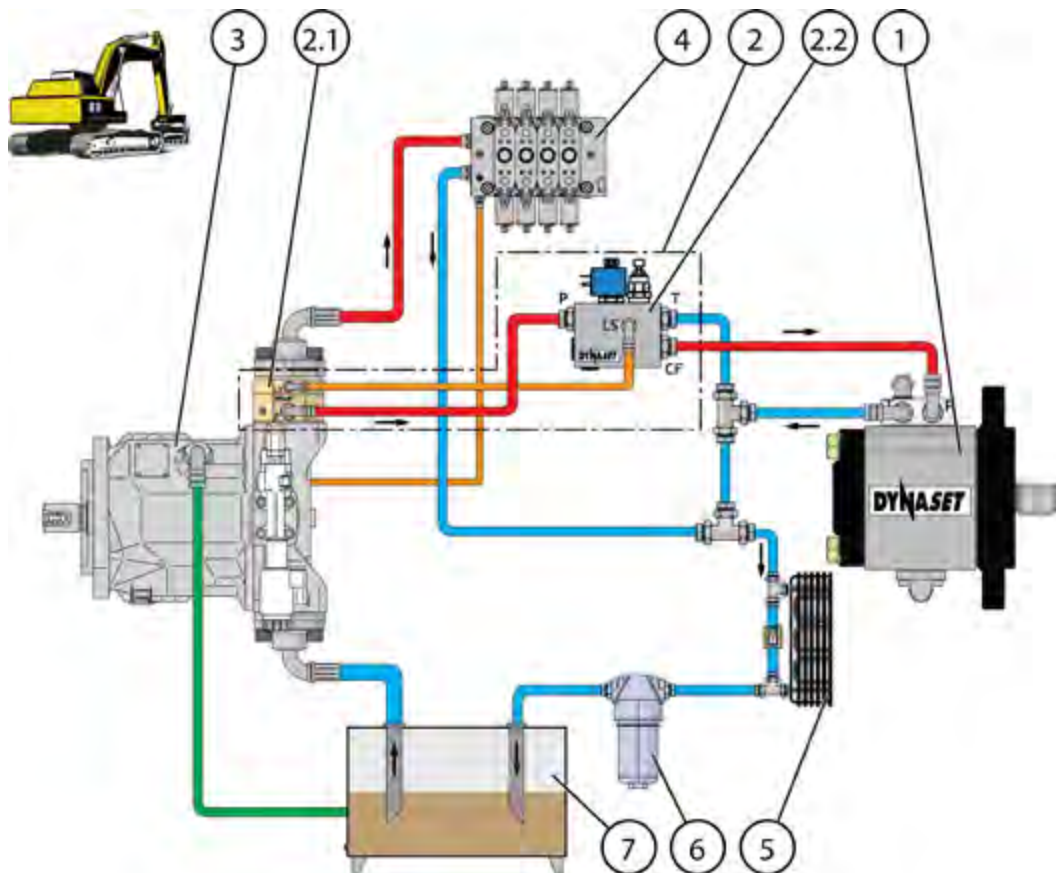

Picture 11: Connection figure for open centre hydraulic system with Load Sensing variable displacement pump

- | | |
|---|---|
| 1. DYNASET hydraulic equipment | 4. Open centre directional control valves |
| 2. DYNASET Priority valve PV-SAE | 5. Oil cooler |
| 2.1. DYNASET PC-SAE pressure compensator | 6. Oil filter |
| 2.2. DYNASET LSV Load sensing valve | 7. Oil tank |
| 3. Base machines variable displacement pump | |

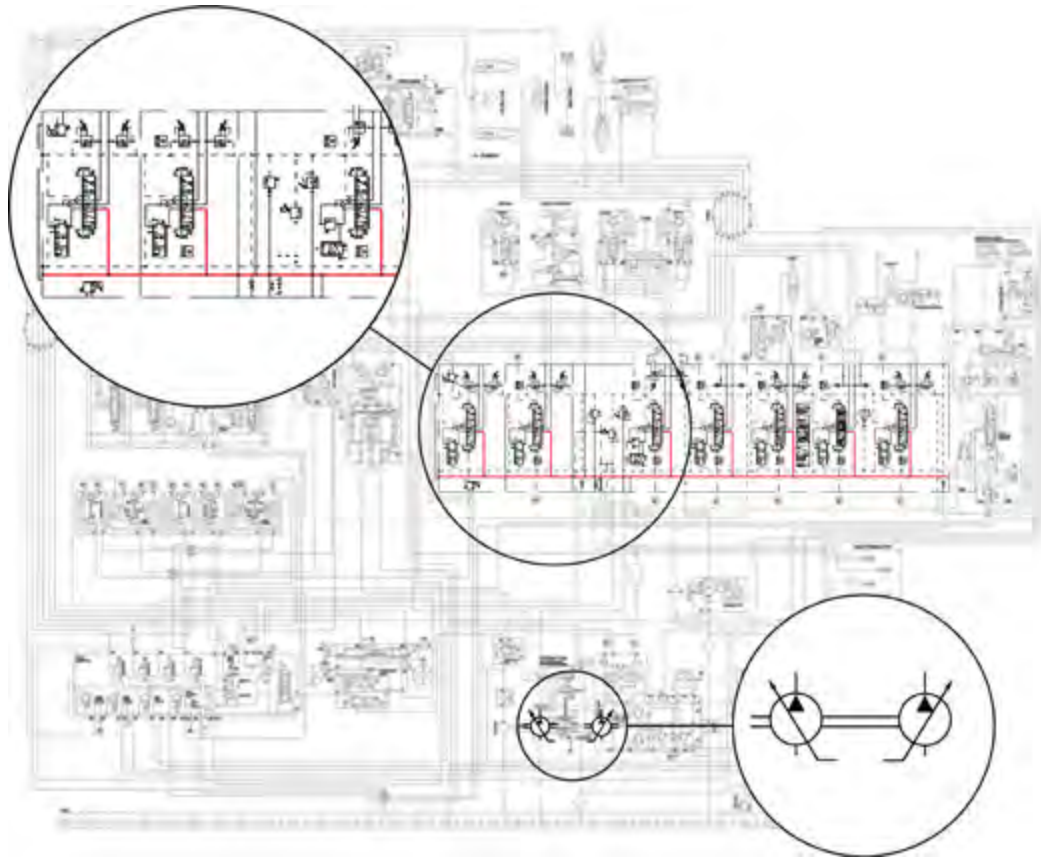
CLOSED CENTRE HYDRAULIC SYSTEM WITH LOAD SENSING VARIABLE DISPLACEMENT PUMP

Picture 12: Closed centre hydraulic system with Load Sensing variable displacement pump

In a closed centre hydraulic system the oil flow is stopped from the pump when control valve is centered. The pump can rest when the oil is not required to operate a function. In Load Sensing variable-displacement pump, the flow rate and output pressure adjusts automatically based on the load of the hydraulic system.

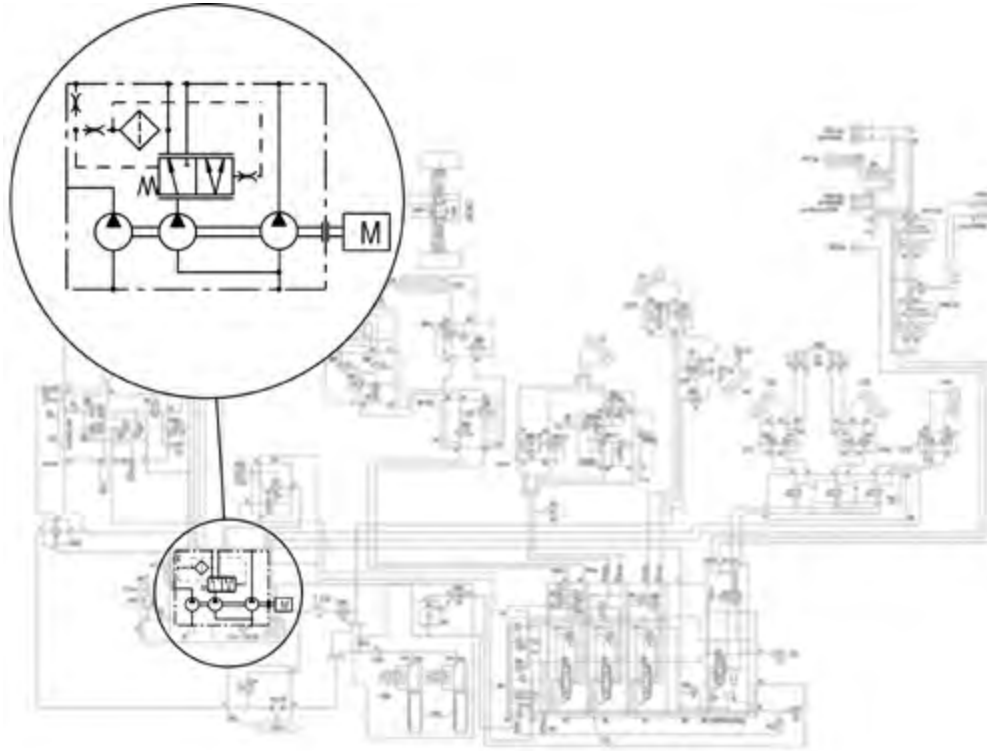
HYDRAULIC SYSTEM WITH FIXED DISPLACEMENT PUMP

Picture 14: Hydraulic system with fixed displacement pump

In hydraulic system which has the fixed displacement pump, the oil flow from the pump is fixed. Every stroke of the hydraulic motor moves the same amount of oil. The output flow is function of the motor's rpm and pump's displacement.

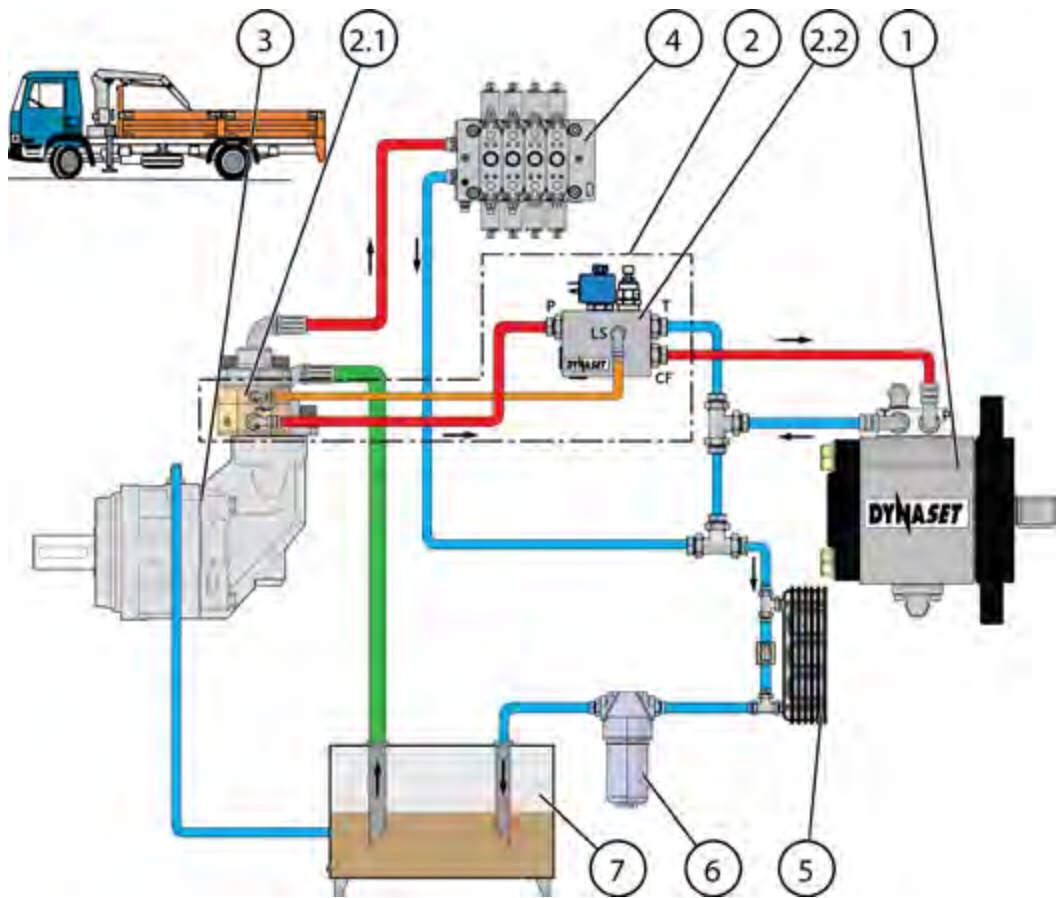

Picture 15: Connection figure for hydraulic system with fixed displacement pump

- | | |
|--|---|
| 1. DYNASET hydraulic equipment | 4. Open centre directional control valves |
| 2. DYNASET Priority valve PV-SAE | 5. Oil cooler |
| 2.1. DYNASET PC-SAE pressure compensator | 6. Oil filter |
| 2.2. DYNASET LSV Load sensing valve | 7. Oil tank |
| 3. Base machines fixed displacement pump | |

4.1.2. DYNASET VALVES

DYNASET valves are designed to enable easy installation of your DYNASET hydraulic product.

DYNASET LOAD SENSING VALVE



Picture 16: Load sensing valve LSV

DYNASET LSV load sensing valves are made for installations in a closed centre hydraulic systems.

DYNASET PRIORITY VALVE

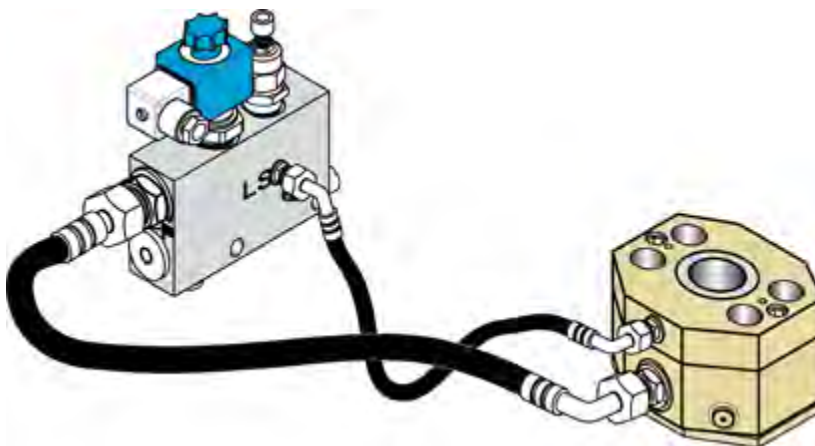

Picture 17: Priority valve PV-SAE

DYNASET PV- SAE priority valve enables the installations of the DYNASET products into any hydraulic system.

4.2. INSTALLING DYNASET HYDRAULIC PRODUCT

4.2.1. PLACING DYNASET HYDRAULIC PRODUCT

Place DYNASET hydraulic product where there is an easy access to the unit. Ensure proper ventilation.

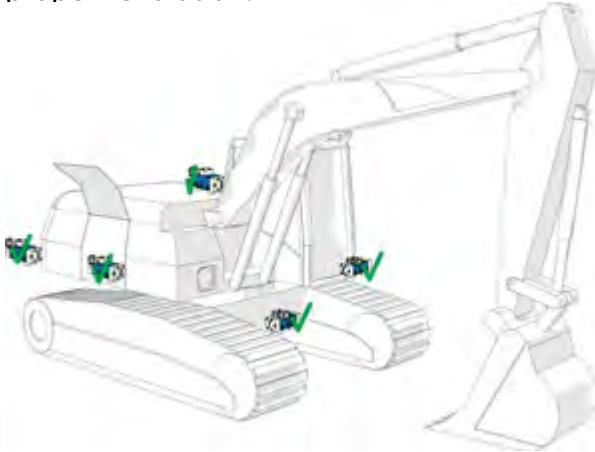

Picture 18: Placing HPW high pressure water pumps

! NOTE!

When positioning the HPW pump note the maximum inclinations and ensure that required oil cooling capacity of hydraulic system is sufficient. READ CHAPTER „10. TECHNICAL SPECIFICATIONS“ for specific cooling capacities.

4.2.2. INSTALLING DYNASET VALVES

Installation instructions can be found in DYNASET LSV or DYNASET PV SAE installation manual.

4.2.3. CONNECTING HYDRAULIC HOSES

Connect pressure- (P) and return (T) lines of a hydraulic system to the corresponding hydraulic ports of the DYNASET unit.

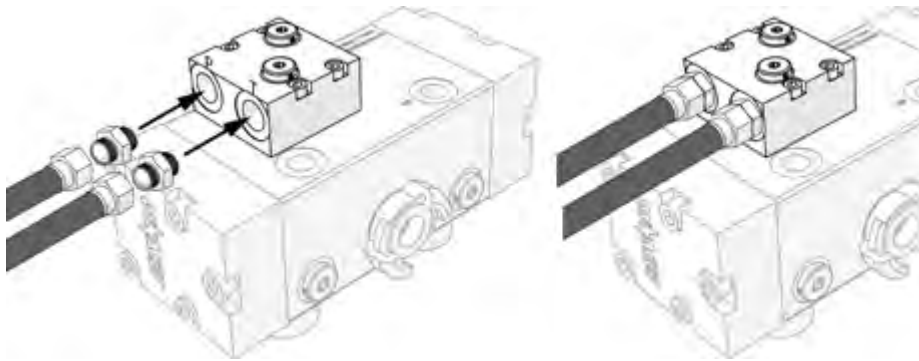

Picture 19: Connecting hydraulic hoses

NOTE!

Location of P- and T-ports varies between different DYNASET hydraulic equipment.

In case of hydraulic flow being too high. The flow must be reduced either by dropping down the rotation speed of base machine's hydraulic pump or using flow limiter valve. DYNASET PV-SAE priority valve is recommended.

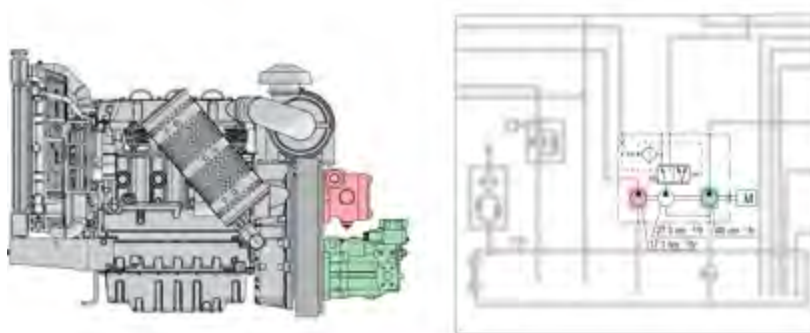

Picture 20: Base machine's pumps

Generally DYNASET products T-line is to be connected directly to the return line of a hydraulic system.

If oil cooler is used between HPW pump and oil tank the return hydraulic pressure should be under 5 bar.

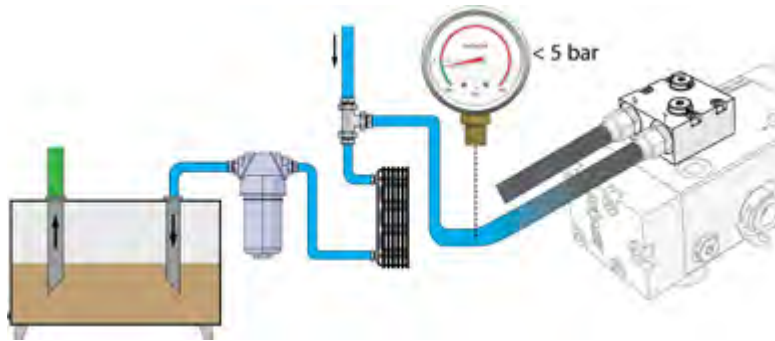

Picture 21: Return line connection

⚠ ATTENTION!

Ensure that the filtering degree and cooling capacity of the hydraulic system are sufficient. READ CHAPTER „10. TECHNICAL SPECIFICATIONS“ for more information.

4.2.4. HYDRAULIC FLUIDS

To use proper hydraulic fluid READ CHAPTER „6.2. Hydraulic fluids“ for more information.

4.3. INSTALLING HPW-PUMP

4.3.1. MAXIMUM INCLINATIONS

Pump should be mounted on sufficiently horizontal surface to enable proper working of leakage detecting holes, which are found either on bottom surface or side faces of pump housing (depends on model).

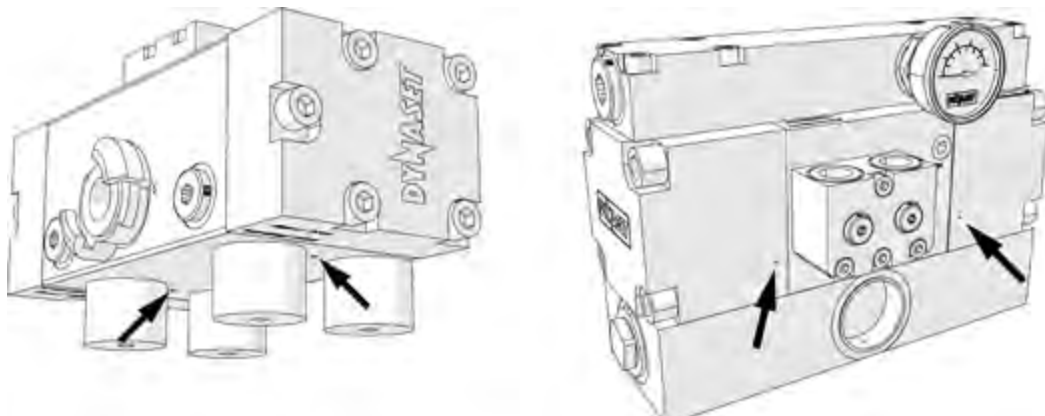

Picture 22: Leakage detecting holes

4.3.2. CONNECTION TO THE PUMPING FLUID INTAKE

Connect water supply line pipe to the intake port (S).

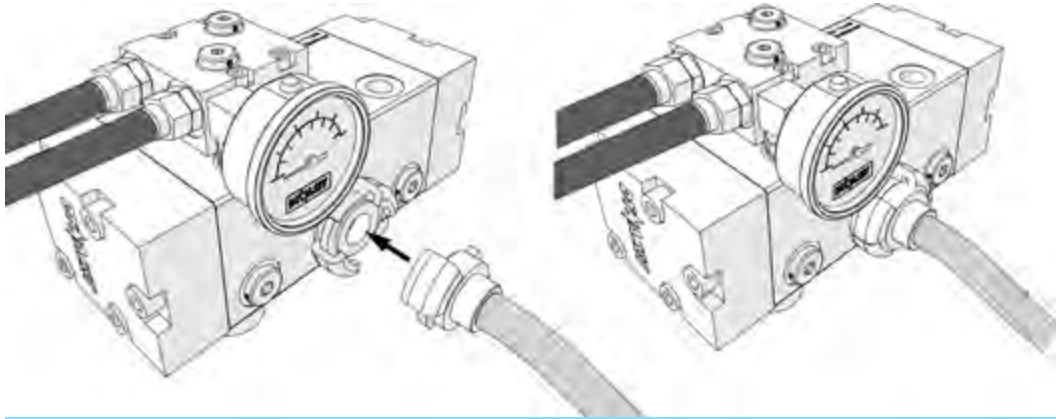

Picture 23: Connection to the pumping fluid intake

When installing HPW pump into pumping fluid line note following things:

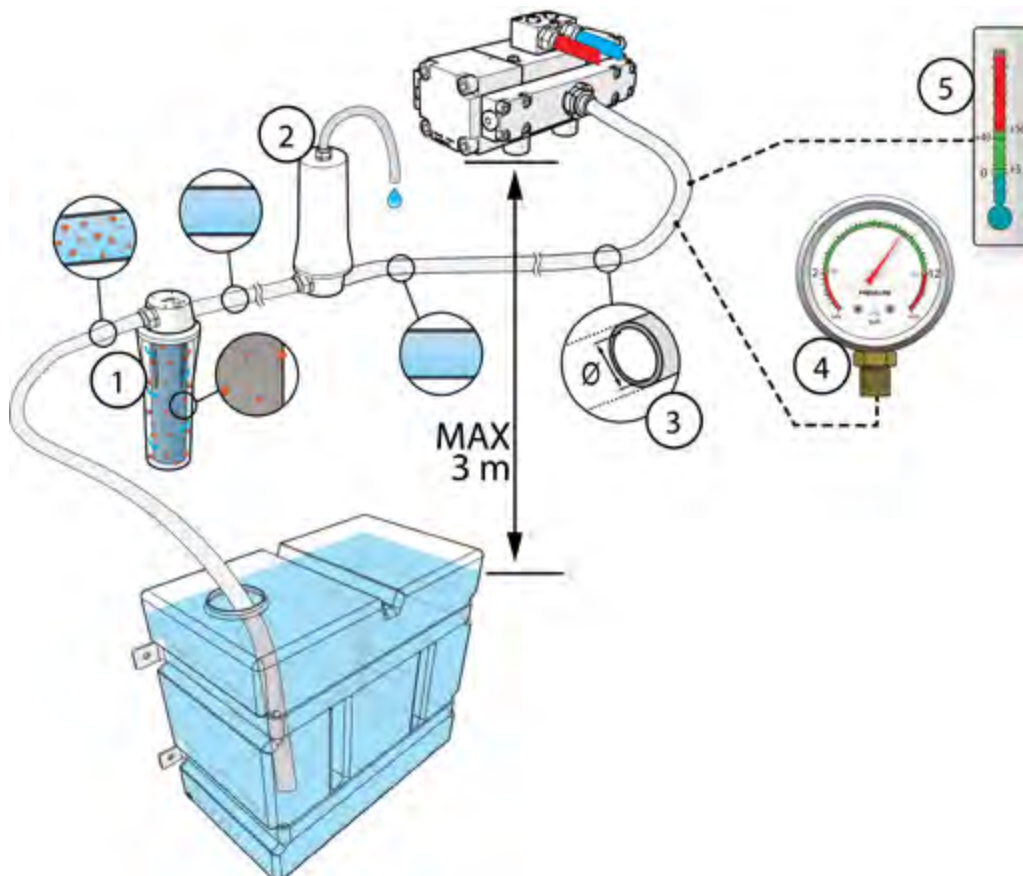

Picture 24: Installation into pumping fluid line

1. Intake filter for pumping fluid.
2. Air separator for pumping fluid.

3. Pumping fluid intake line hose diameter.
4. Pumping fluid intake line can be pressurised, maximum feed pressure can be typically 16 bar.
5. Pumping fluid temperature, typically between 5 to 70 °C
6. Most HPW pumps can be used as self-priming and the head of a pumping fluid intake line is typically 3 m as maximum.

! NOTE!

READ CHAPTER „10. TECHNICAL SPECIFICATIONS“ for specific characteristics of your HPW pump.

4.3.3. CONNECTION TO THE PUMPING FLUID OUTPUT

Connect the water or other pumping fluid output line to the water pressure port (WP).

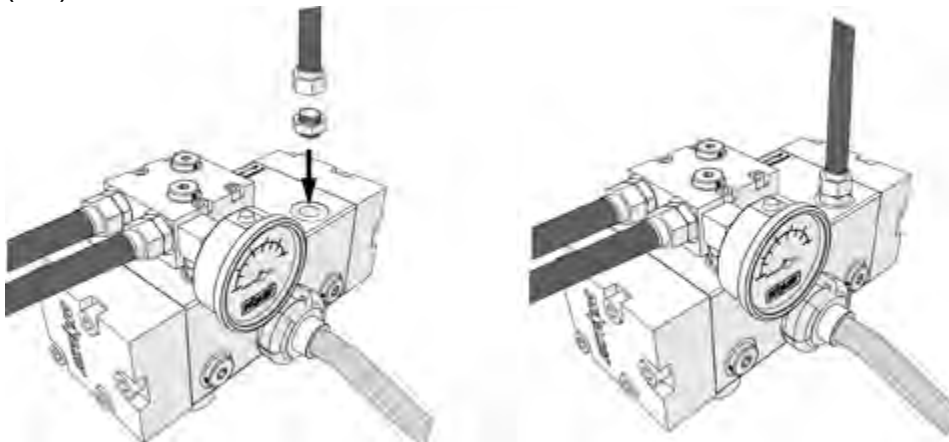

Picture 25: Connection to the pumping fluid output

5. OPERATION

5.1. STARTING THE HPW PUMP

⚠ ATTENTION!

Check all hoses and couplings in hydraulic and pumping fluid circuits before use to ensure there are no leaks or damages.

Ensure that there is water or other pumping fluid available in intake line.

When the engine of base machine is running and hydraulic flow is available, the HPW pump can be started by opening the hydraulic control valve.

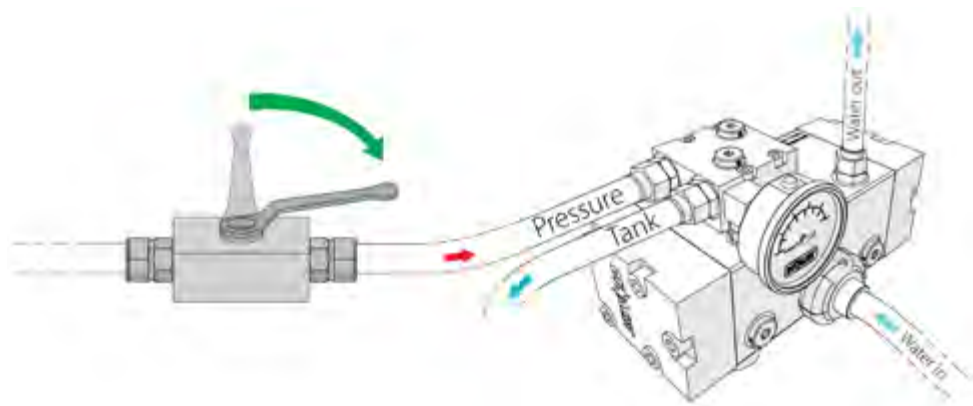

Picture 26: Starting the HPW pump

⚠ ATTENTION !

Never put your hand, fingers or body directly in front of the spray nozzle!

The spray nozzle attached to a pressure tool determines the flow rate and the pressure when operating parameters of hydraulic circuit meet the HPW pump's requirements.

Correct size of the spray nozzle of pressure tool is a very important step for ensuring the optimal water jet or hydro-demolition power in each application.

5.2. ADJUSTING FLOW RATE AND PRESSURE OF PUMPING FLUID

5.2.1. ADJUSTING FLOW RATE AND PRESSURE WITH WATER UNLOADER VALVE

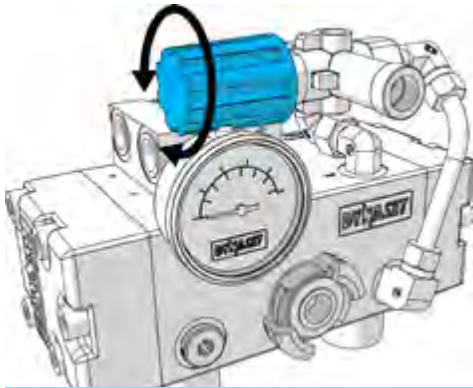

Picture 27: HPW pump with water pressure unloader valve

1. The water unloader valve is used to adjust the desired maximum output pressure limit. The adjusting knob is tightened to increase pressure and loosened to decrease pressure.
2. Whereupon the adjusted maximum pressure limit is being reached, water unloader valve circulates the water within the pump and prevents the output pressure to rise over the limit.

5.2.2. ADJUSTING FLOW RATE AND PRESSURE WITHOUT WATER UNLOADER VALVE

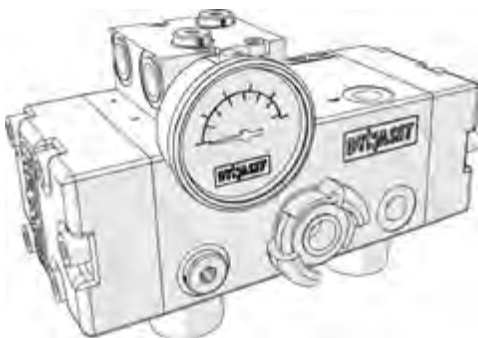

Picture 28: HPW pump without water pressure unloader valve

1. The water pressure and flow are adjusted by adjusting corresponding parameters in the hydraulic circuit.
2. In circuits based on fixed displacement pump closing the water pressure line opens the pressure relief valve in hydraulic system.

! NOTE!

Hydraulic fluid circulation through pressure relief valve causes heating of oil and hydraulic system!

3. In circuits based on variable displacement hydraulic pump closing the water pressure line adjusts hydraulic pump's swashplate at 0° angle. Hydraulic pump produces flow only for self-lubrication and self-flushing.

5.3. PUMPING FLUIDS

Most liquids, which can be transferred by pumping, can be pumped also with HPW pump.

Water based fluids and seawater can be pumped without any special arrangements, however the pump must be flushed and cleaned thoroughly after a working shift with clean fresh water. Same rule applies when pumping gelatinous fluids, flush HPW pump with clean fresh water or suitable solvent. Solvents, fuels and oils can be pumped without any special arrangements.

Fluids with abrasives or high content of solids can be pumped as well, but should be kept in mind, that HPW pump's service lifetime is considerably shortened.

Note that DYNASET HDF-pump series is especially designed for pumping abrasive fluids. If pumping solution is aggressive to NBR-rubber, special seals must be used.

When HPW pump is going to be used as a self-priming unit with a special or high viscosity liquid, the flow and self-priming conditions should be valuated. If the self-priming property can not be reached, pumping liquid is to be fed with certain pressure, or the pump should be used at lower hydraulic flow. READ CHAPTER „5.3. Pumping fluids“ for specific values of your HPW pump.

HPW-models made of special materials are available by request.

! NOTE!

HPW pump can be run dry unlimited time without any harm, because self-lubricating sealing and circulating hydraulic oil prevent the pump from overheating.

5.4. WORKING IN COLD TEMPERATURES

To prevent pipes and HPW pump from freezing in cold season, pump and pumping fluid output line should be dewatered after a working shift. Detach the intake hose from HPW pump and run it dry for a while until all water is removed from water circuit.

5.5. STOPPING THE HPW PUMP

HPW pump is stopped by shutting off the hydraulic flow.

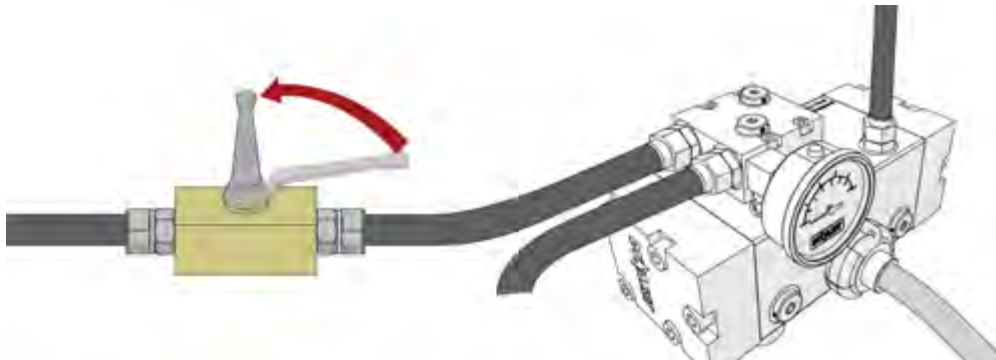

Picture 29: Stopping the HPW pump

High pressure can remain in closed pressure circuit. Release water pressure to avoid unexpected water discharges and injuries. If spray gun or similar tool has been used, pull the trigger for some time after the pump has stopped.

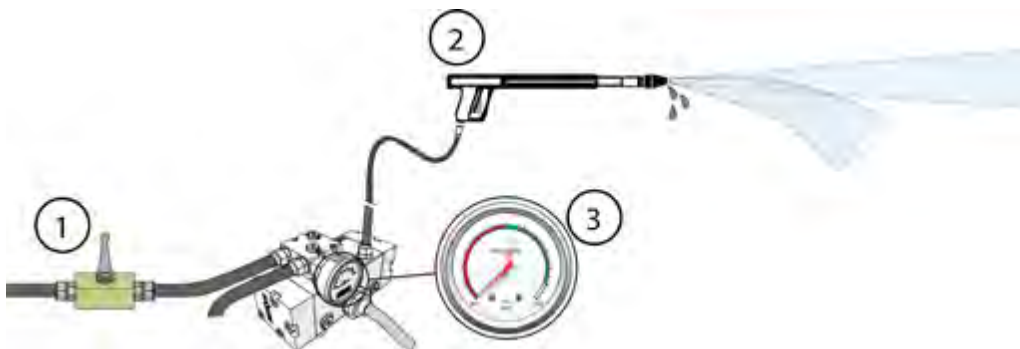

Picture 30: Stopping procedure of the HPW pump

1. Shut off hydraulic flow.
2. Pull the trigger of spray gun to let the pressure out the system.
3. Ensure that there is no pressure left in the system from the pressure gauge.

NOTE!

Clean the pump completely after work, if special pumping fluid is used! READ CHAPTER „5.3. Pumping fluids“ or contact your supplier for use of special pumping fluids.

6. MAINTENANCE

DYNASET HPW pumps are low-maintenance pumps. In normal operating conditions HPW pump does not require any other service, except replacement of sealings or occasionally replacement of water valves. It depends on content of abrasives in pumping fluid, as well as on cleanliness of hydraulic oil.

ATTENTION!

Before beginning any maintenance or repair, ensure that the system is stopped and completely depressurized. Make sure that the system can not start accidentally.

6.1. MAINTENANCE INTERVAL

All maintenance must be complied with as they are scheduled in this manual. The following table provides maintenance schedule for DYNASET HPW pumps.

CHECK POINTS	Daily	After daily use	Every 3 months	Every 1500 hours or if necessary
Observe leakage detectors	x			
Clean HPW pump		x		
Change water intake filter			x	
Change sealings				x

Check constantly whether the fluid dropping from pump's leakage detectors is growing. Replace sealing in proper time to exclude intermixing of hydraulic oil and pumping fluid.

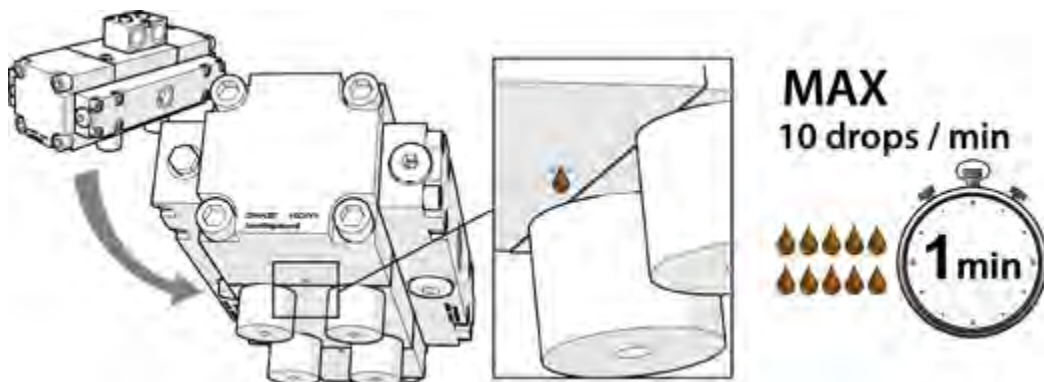

6.2. HYDRAULIC FLUIDS

Wide range of standard hydraulic fluids can be used with DYNASET hydraulic equipment. Depending on the operating temperature, following mineral hydraulic oils are recommended:

Mineral hydraulic oil	Operation temperature up to
ISO VG 32S	60 °C
ISO VG 46S	70 °C
ISO VG 68S	80 °C

! NOTE!

Recommended oil viscosity is between 10 to 35 cSt when operating at normal operating temperature.

Synthetic and bio-oils can also be used if their viscosity characteristics and lubricating efficiency are similar to the mineral oils.

Automatic transmission fluids and even engine oils can be used, provided that they are allowed to be used in hydraulic system of your base machine.

For the hydraulic fluid change interval follow the base machine's maintenance instructions.

To use special hydraulic fluids with DYNASET equipment, please contact the nearest DYNASET representative for more information.

6.3. CLEANING THE HPW PUMP

! ATTENTION!

Keep the HPW pump clean to enable its safe and longlife operation. Check and clean your HPW pump after every work shift.

6.4. REPLACING WATER VALVES

1. Remove screws from the head.

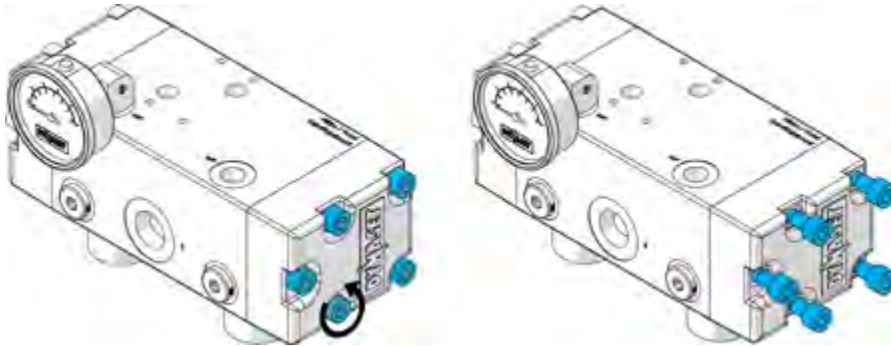

2. Pull out the head.

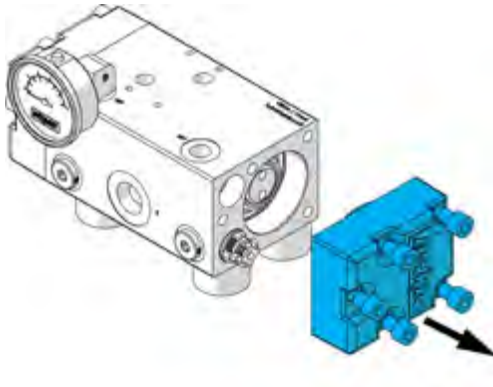

3. Remove water valves and O-rings.

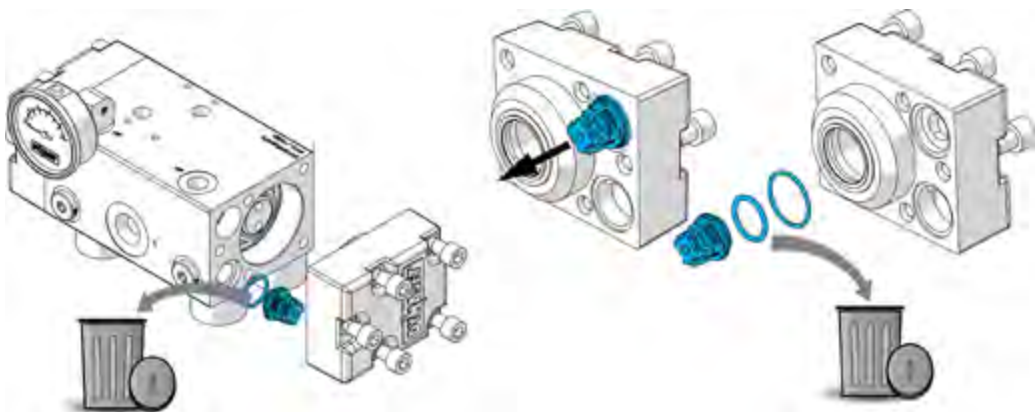

⚠ ATTENTION!

The pressure valve's spring has less turns than the suction valve's spring.
Do not mix up the valves when re-assembling the pump!

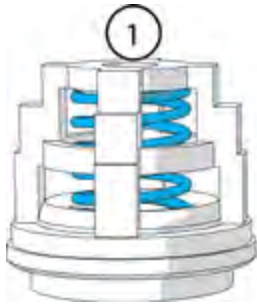

1. Suction valve



2. Pressure valve

4. Install new suction (1) and pressure (2) valves.

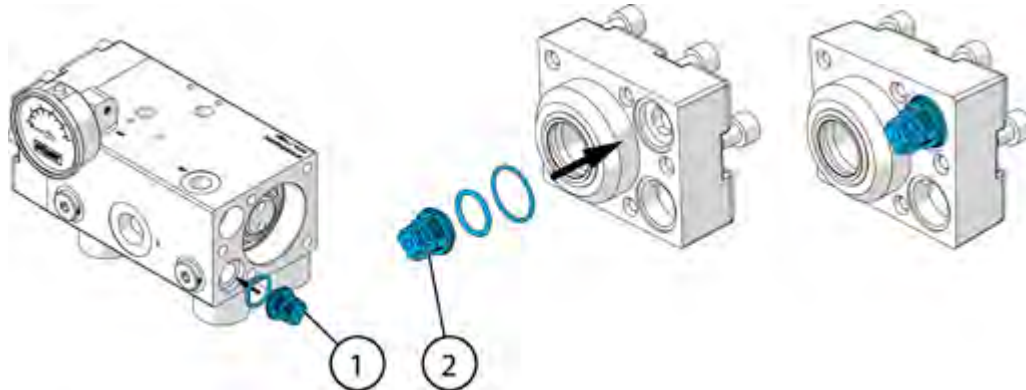

5. Install the head. Tighten heads bolts across, see chapter READ CHAPTER „6.6. Bolt tightening torques“

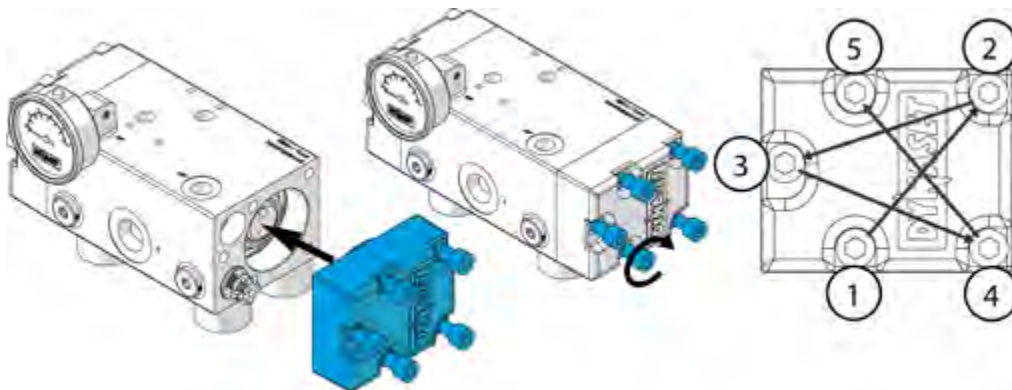

6. Repeat the operation to the other head.

6.5. REPLACING PUMP SEALS

1. Remove screws from the head.

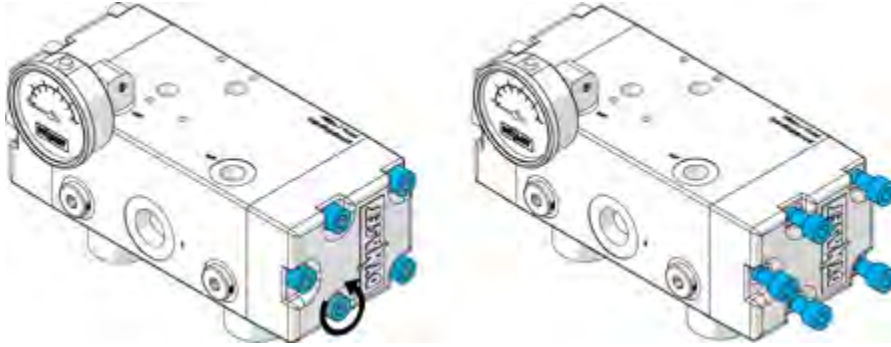

2. Pull out the head and remove water valves.

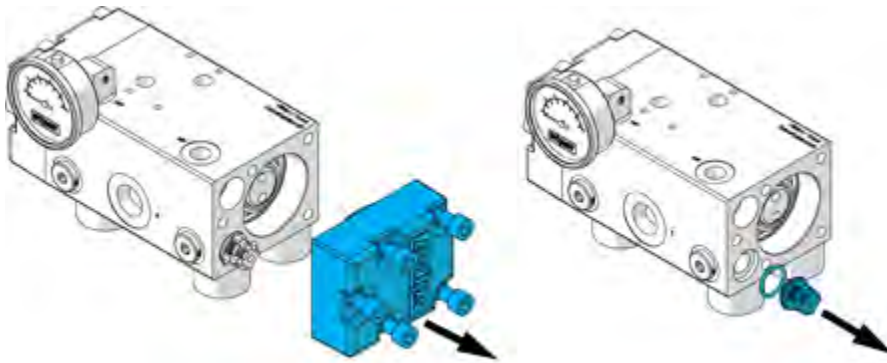

3. Remove the other head and water valves.

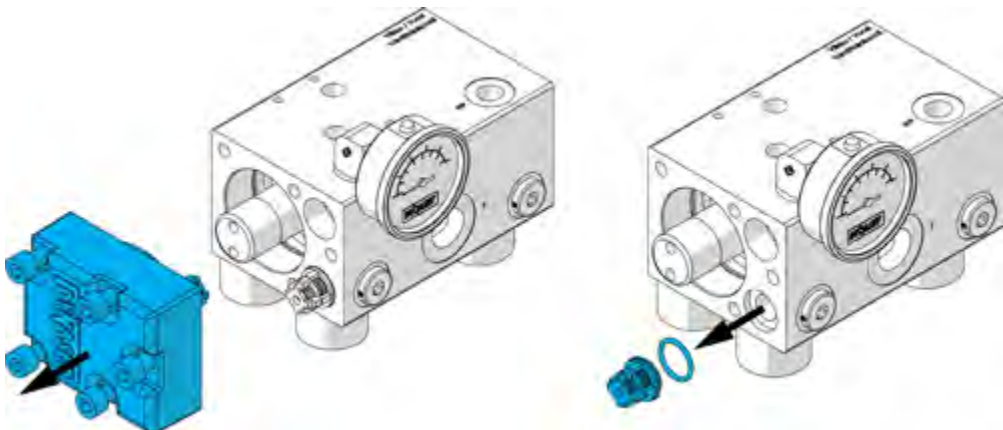

4. Turn the pump frame into a vertical position.

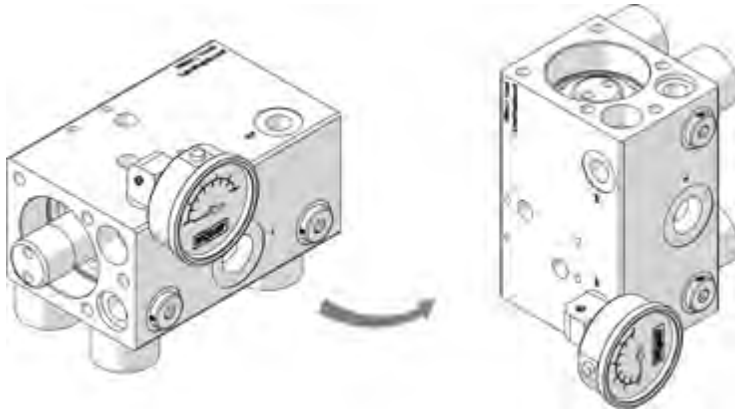

5. Use rubber hammer and special tool to remove piston assembly with cylinder and sealing flanges from the pump.

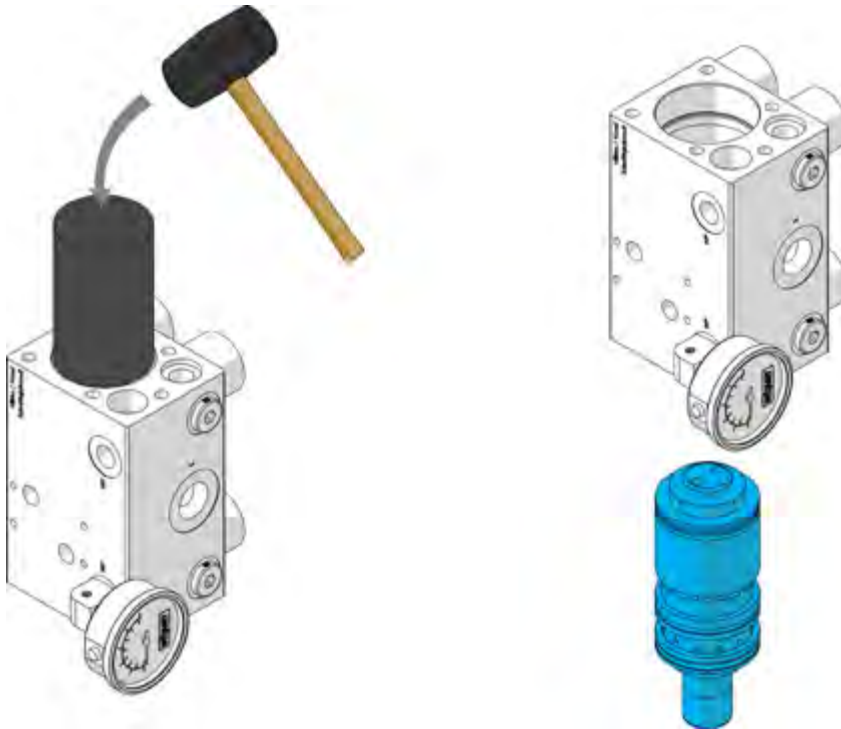

6. Remove the sealing flanges from the piston assembly.

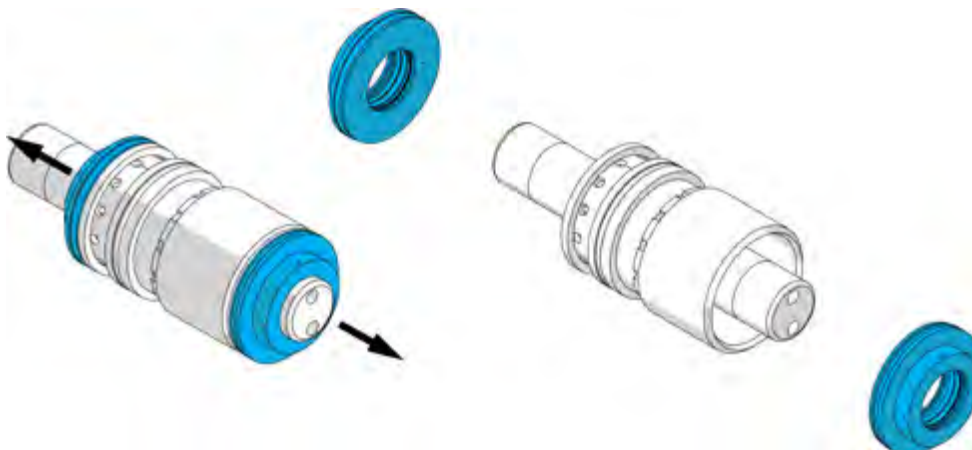

7. Remove seals and o-rings from the sealing flanges.

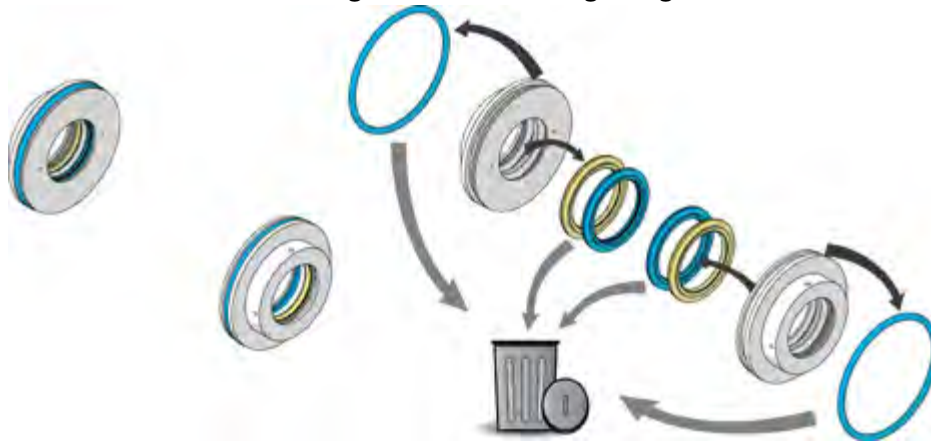

8. Remove the piston assembly from the cylinder.

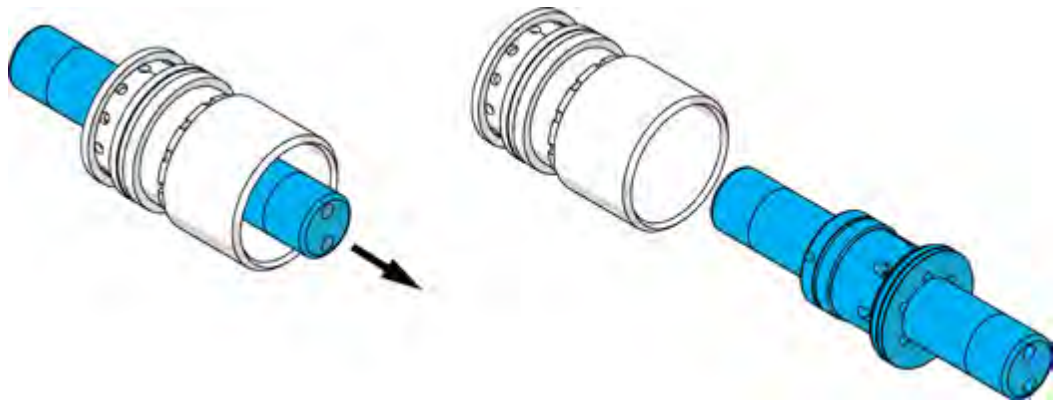

9. Remove seal from the piston assembly and o-ring from the cylinder.



10. Install new o-ring to the cylinder, new o-ring and seal to the piston assembly.

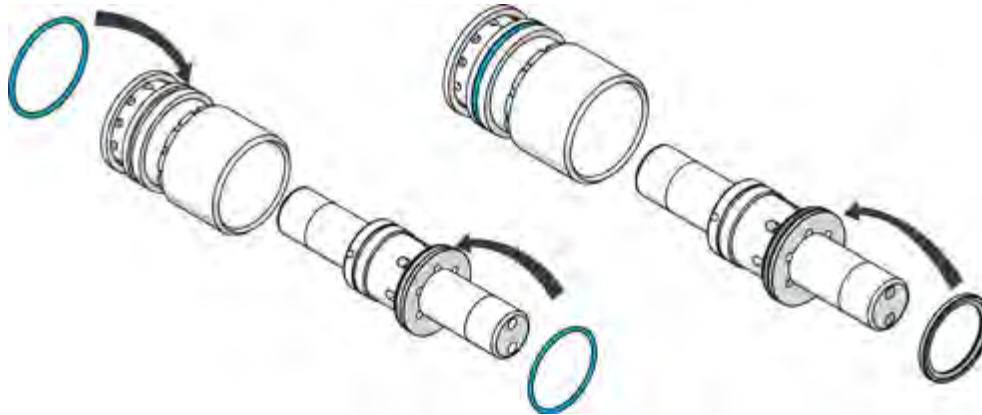

11. Install the piston assembly to the cylinder. Use vaseline or mineral oil on the seal and mating surfaces to make installation easy.

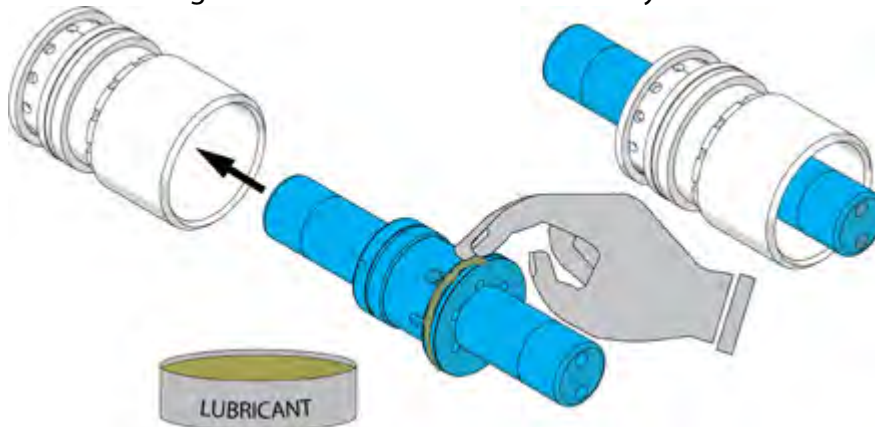

12. Install new o-rings and seals to the sealing flanges. First install o-rings and then the seals. Compress the seal into a kidney shape, place it into groove and push it back to normal shape. Avoid making sharp bends on the seal.

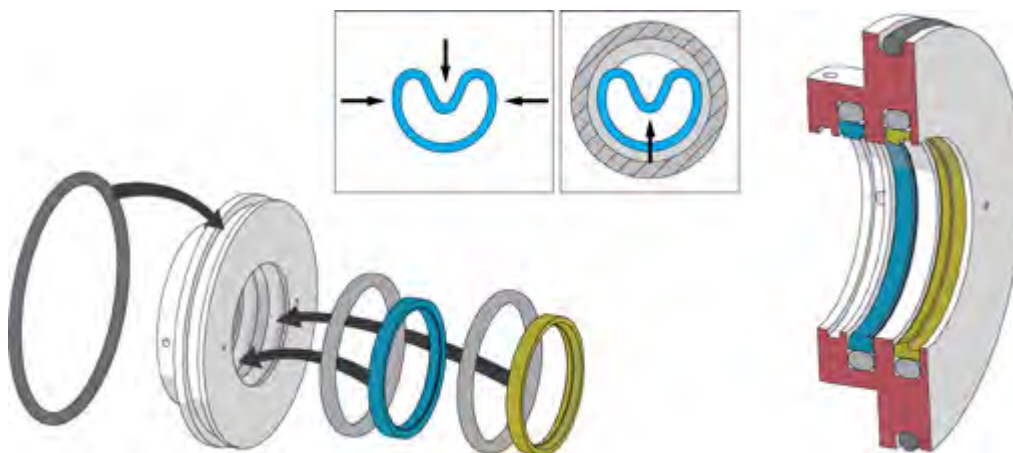

 **ATTENTION!**

Seals of the sealing flange differs from each other, make sure that correct seal is installed into correct place.

13. Install sealing flanges into the piston assembly. Use lubricant to make the installation easy.

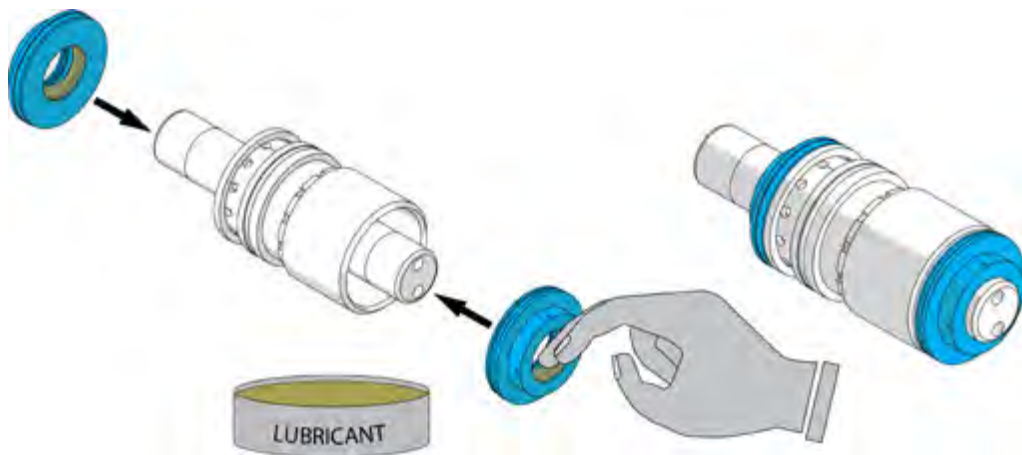

14. Lubricate mating surfaces of the piston assembly and insert it to the body. Place the special tool in the top of the piston assembly.

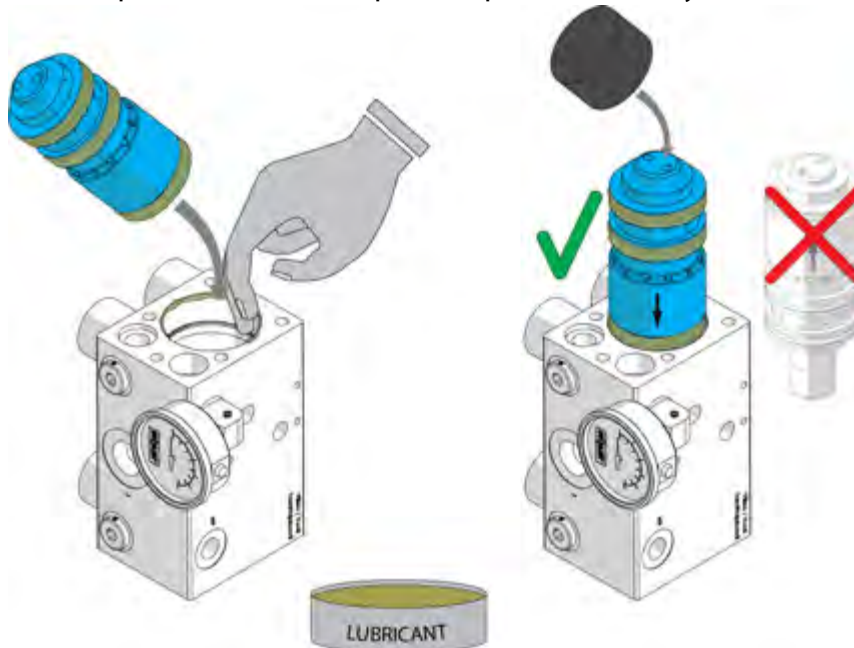

! NOTE!

Make sure that the piston assembly is installed correctly.

15. Use rubber hammer to install piston assembly into the body.

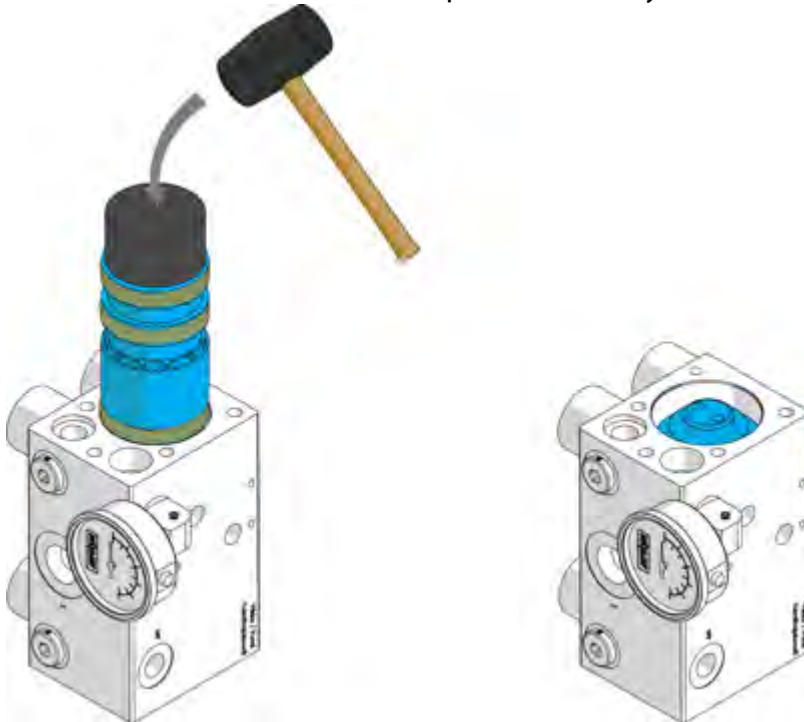

16. Remove seals from the heads.



17. Install new seals into the heads.

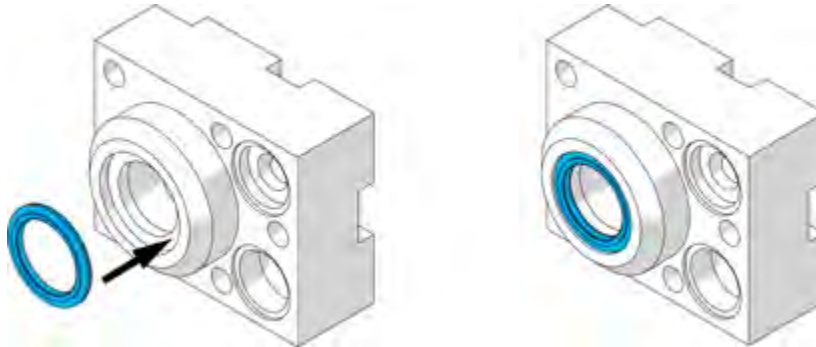

18. Install water valves. READ CHAPTER „6.4. Replacing water valves“.

! NOTE!

DYNASET recommends replacing the water valves at the same time as the pump seals.

19. Install both heads into the body. Tighten heads bolts across, see chapter READ CHAPTER „6.6. Bolt tightening torques“

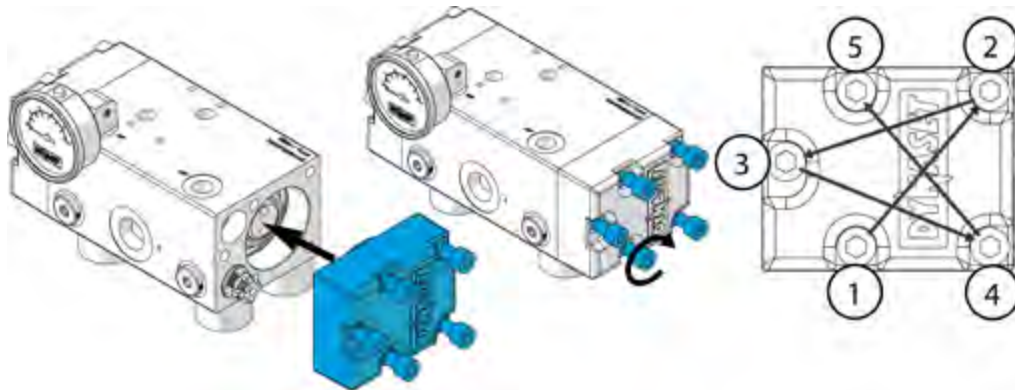

20. Test run the pump and make sure that there are no leakages.

6.6. BOLT TIGHTENING TORQUES

BOLT		TIGHTENING TORQUE
M6	8.8, SS	9 Nm (6.5 lb ft)
M8	8.8, SS	22 Nm (16.0 lb ft)
M10	8.8, SS	45 Nm (33.0 lb ft)
M10	12.9	75 Nm (55.0 lb ft)
M12	8.8, SS	75 Nm (55.0 lb ft)
M12	12.9	135 Nm (99.5 lb ft)
M16	8.8, SS	180 Nm (133.0 lb ft)
M16	12.9	300 Nm (221.0 lb ft)

*SS = Stainless Steel

6.7. TROUBLESHOOTING

Performing the maintenance tasks requires a qualified hydraulic mechanic. Please, contact DYNASET authorized workshop or dealer for more maintenance information.

FAILURE	REASON	CORRECTIVE ACTION
HPW pump does not work.	Hydraulic flow not sufficient or no hydraulic flow at all.	Enable or adjust the hydraulic flow.
	Hydraulic pressure too low.	Adjust the hydraulic pressure.
	Hydraulic flow reversed.	Check and reconnect hydraulic hoses. Pressure hose should be connected to P-port and return hose to T-port.
	Hydraulic piston damaged mechanically.	Replace damaged part.

FAILURE	REASON	CORRECTIVE ACTION
HPW pump works, but does not deliver water flow.	Water intake and pressure valves are open (jammed with debris) or damaged.	Check water valves and clean them thoroughly or replace when damaged.
	Regulator's unloader valve opens from intake to pressure (models with water pressure unloader valve).	Check the valve and repair failure.

FAILURE	REASON	CORRECTIVE ACTION
HPW pump does not receive pumping fluid	Intake hose detached or hose breathes.	Check and fix the hose and connectors.
	Water supply line clogged.	Check strainer or water filter and clean thoroughly.
	Suction head too high.	Check the performance with pressurized water supply when possible.

FAILURE	REASON	CORRECTIVE ACTION
Water pressure line blocked.	Nozzle clogged.	Check the nozzle and clean thoroughly.
	Regulator's check valve damaged, pressure line blocked (models with water pressure unloader valve).	Check the valve and repair failure.

FAILURE	REASON	CORRECTIVE ACTION
Water flow rate too small	Insufficient hydraulic flow or pressure.	Adjust the hydraulic flow to the demanded level at required pressure.
	Nozzle of your pressure tool undersized.	Verify the nozzle sizing and replace with proper one.
	Pressure loss in delivery hose.	Verify the hose sizing and replace with proper one.
FAILURE	REASON	CORRECTIVE ACTION
Water pressure too low	Insufficient hydraulic flow or pressure.	Adjust the hydraulic pressure to the demanded level at required hydraulic oil flow. Pressure loss should be minimized - Do not use hoses of too small diameter or/and of an excessive length.
	Nozzle of pressure tool oversized.	Verify the nozzle sizing and replace with proper one.
	Wear-out of nozzle.	Replace the nozzle.
	Insufficient water supply.	Check and fix the problem. Use pressurised water supply if available.
	Water pressure unloader valve set too low (models with water pressure unloader valve).	Check and re-adjust to specification.
FAILURE	REASON	CORRECTIVE ACTION
Intence pulsating of water pressure.	Some of water intake and pressure valves are open or damaged.	Check water valves, clean thoroughly or repair.
	Water intake line breathes causing pump cavitation.	Check water intake line and fix the problem.
	Water intake line's diameter to small, resulting in pump cavitation.	Verify the hose sizing and replace with proper one.
	Excessive hydraulic flow, when HPW-pump runs too fast.	Adjust the hydraulic flow to the demanded level.
	Filter clogged or too small.	Clean filter or replace filter of correct size.



HIGH PRESSURE WATER PUMPS MAINTENANCE

FAILURE	REASON	CORRECTIVE ACTION
<p>Closing the water pressure line does not drop pressure to free circulaiton mode.</p> <p>Hydraulic system starts to run through the pressure relief valve, emitting excessive heat.</p>	<p>Insufficient hydraulic pressure in relation to pumping fluid pressure, adjusted with water pressure unloader valve.</p>	<p>Adjust the hydraulic pressure up as much as necessary to enable proper operation of water pressure unloader valve. Note that the maximum hydraulic pressure should not be overrun!</p> <p>If boosting the hydraulic pressure is not possible, the water unloader pressure setting should be dropped.</p>
	<p>Defective water pressure unloader valve (models with water pressure unloader valve).</p>	<p>Repair or replace water pressure unloader valve.</p>
FAILURE	REASON	CORRECTIVE ACTION
<p>Sealings and water pistons wear off repeatedly.</p>	<p>Broken filter.</p>	<p>Check and replace filter.</p>
	<p>Filter missing totally.</p>	<p>Install filter. Always must use filter, even with clear tap water.</p>
<p>Leakages.</p>	<p>Hydraulic oil leakages.</p>	<p>Check the tightness of component mating, tighten screws.</p>
		<p>Replace sealings of pumps mated surfaces if necessary.</p>
		<p>Check and tighten couplings. Replace if necessary.</p>
	<p>Pumping fluid leakages.</p>	<p>Check the tightness of component mating, tighten screws.</p>
		<p>Replace sealings of pumps mated surfaces if necessary.</p>
		<p>Check and tighten couplings. Replace if necessary.</p>
<p>Hyraulic oil-pumping fluid leakage.</p>	<p>If the draining from leakage detectors exceeds rate of 10 drops per minute, pump's sealings should be replaced.</p> <p>The rule applies to dropping of hydraulic fluid, pumping fluid and their commixture.</p>	

7. MANUFACTURER'S LIMITED WARRANTY

1. Warranty coverage

All hydraulic accessories manufactured by DYNASET OY are subject to the terms and conditions of this limited warranty. Products are warranted to the original purchaser to be free from defects in materials or workmanship. Exclusions from warranty are explained in item Exclusions from warranty.

2. Beginning of warranty period

Warranty period begins from the delivery date of the product. Delivery is considered to be done on the date when installation has been accomplished or purchaser has taken the product in use. Product is considered as taken in use at the date when DYNASET OY has delivered the product to purchaser, unless separately agreed otherwise by written agreement.

3. Warranty period

Warranty period is twenty four (24) months based on maximum of 2000 hours usage during this time period. In cases where the system is provided complete with certain special components (e.g. drive unit), those components are considered as a subject to their manufacturer's warranty.

4. Warranty procedures

Immediately upon identifying a problem which purchaser believes to be a failure subject to the product's limited warranty, purchaser must contact primary to the seller of the product. Contact must be made as soon as possible, latest thirty (30) days after the problem was identified. Seller and/or manufacturer technical staff determines the nature of the problem primarily by phone or e-mail. Purchaser commits to give necessary information and to perform routine diagnostic procedures in order to determine the nature of the problem and necessary procedures.

5. Warranty repairs

If the product is found to be defective during the warranty period, DYNASET OY will, at its option, either repair the product, author it to be repaired at its authorized workshop or exchange the defective product. If the product must be repaired elsewhere than premises of DYNASET OY or authorized workshop, all costs excluded from this warranty (traveling and waiting hours, daily allowance, traveling expenses and uninstallation/reinstallation costs) will be charged from the purchaser. If the problem is not covered by this limited warranty, DYNASET OY has the right to charge purchaser of troubleshooting and repairing.

6. Delivery terms of warranty repair

If the product is found possible to be defective under this limited warranty and it needs to be repaired, DYNASET OY gives Warranty Return Number (WRN). Items being returned must be shipped, at the purchaser's cost, adequately packed for shipment, to the DYNASET OY or to other location authored by DYNASET OY.

Shipment documents must contain:

- Purchaser's name and contact information
- Receipt of original purchase
- WRN code
- Problem description



HIGH PRESSURE WATER PUMPS WARRANTY

7. Warranty of repaired product

Warranty period of the product repaired under this limited warranty continues to the end of original warranty period.

8. Exclusions from warranty

This warranty shall not apply to:

- Failures due to normal wear and tear, improper installation, misuse, abuse, negligence, purchaser selection of improper product to intended use, accident, improper filtration of hydraulic oil or intake water or lack of maintenance.
- Cost of maintenance, adjustments, installation or startup.
- Coating, hydraulic oil, quick couplings and interconnection hoses (internal or external to system assemblies).
- Products altered or modified in a manner not authorized by DYNASET OY in writing.
- Products which have been repaired during warranty period by others than DYNASET OY or its authorized workshop.
- Costs of any other damage or loss, whether direct, indirect, incidental, special or consequential, arising out of the use of, or the inability to use, the product.
- Telephone or other communications expense.
- Product that is used in exceptional conditions, considered to cause excessive wear and tear.
- Faults caused by nature phenomenon's like flood, thunder, etc.

© DYNASET OY, all rights reserved



8. PRODUCT DISPOSAL

Dispose and recycle all DYNASET products and their packaging environmentally responsible way.

Do not dispose used oils, electrical components, batteries or any other hazardous waste with normal waste. They are harmful for the environment and can be recycled for re-use.

Contact your local waste recycling facility for more information about recycling hazardous waste.

! NOTE!

Always act according to the waste legislation, regulations and recommendations in waste disposal and waste recycling issued by your local authorities.

9. DECLARATION OF CONFORMITY

We hereby declare that the design and manufacture of the product stated below are in conformity with the provisions of the European Parliament and Councils on the harmonization of the laws of Member States on the safety of machines.

Machine directive 2006/42/EC

LVD directive 2014/35/EU

EMC directive 2014/30/EU

Applied conformity standards:

CEN EN ISO 4413: EN ISO 4413:2010 Hydraulic fluid power - General rules and safety requirements for systems and their components.

EN60204-1 Safety of machinery – Electrical equipment of machines.

Manufacturer: **DYNASET Oy**
Menotie 3, FI-33470 Ylöjärvi, Finland

Product group: HIGH PRESSURE WATER PUMPS

Product: HPW High pressure water pumps

If the device has been modified by someone other than the manufacturer or without the manufacturer's permission, this declaration is not valid.



Timo Nieminen
R&D Manager
Ylöjärvi, Finland 20.04.2016



HIGH PRESSURE WATER PUMPS TECHNICAL SPECIFICATIONS

10. TECHNICAL SPECIFICATIONS

		HPW 200 /30-45	HPW 420 /20-50	HPW 220 /50-70	HPW 90 /150-85	HPW 520 /30-85	HPW 180 /90-115	HPW 460 /50-115	HPW 130 /180-140
DISCHARGE CHARACTERISTICS									
Pumping fluid flow max.	l/min (gpm)	30 (7.9)	20 (5.3)	50 (13.2)	150 (39.6)	30 (7.9)	90 (23.8)	50 (13.2)	180 (47.6)
Pressure max.	bar (psi)	200 (2900)	420 (6100)	220 (3200)	90 (1300)	520 (7500)	180 (2600)	460 (6700)	130 (1900)
Power	kW	10	14	18,5	22,5	26	27	38	39
Water/hydraulic pressure ratio		1,18	2,12	1,26	0,52	2,62	1,12	2,03	0,68
HYDRAULIC CONNECTIONS									
Pressure line	P	BSP 1/2"	BSP 1/2"	BSP 3/4"	BSP 3/4"	BSP 3/4"	BSP 3/4"	BSP 3/4"	BSP 3/4"
Return line	T	BSP 1/2"	BSP 1/2"	BSP 3/4"	BSP 3/4"	BSP 3/4"	BSP 3/4"	BSP 3/4"	BSP 3/4"
Service line	CMP	-	-	-	BSP1/8"	BSP1/8"	BSP1/8"	BSP1/8"	BSP1/8"
Outlet line	WP	BSP 3/8"	BSP 3/8"	BSP 1/2"	BSP 1"	BSP 3/8"	BSP 3/4"	BSP 1/2"	BSP 1"
Intake line	S	BSP 3/4"	BSP 3/4"	BSP 1"	BSP 2"	BSP 3/4"	BSP 1 1/4"	BSP 1"	BSP 2"
HYDRAULIC POWER REQUIREMENTS									
Oil flow max.	l/min (gpm)	40 (10.6)	50 (13.2)	70 (18.5)	85 (22.5)	85 (22.5)	115 (30.4)	115 (30.4)	140 (37.0)
Operating pressure	Δp. bar (psi)	210 (3000)	210 (3000)	210 (3000)	210 (3000)	210 (3000)	210 (3000)	240 (3500)	240 (3500)
Pressure max.	bar (psi)	210 (3000)	220 (3200)	210 (3000)	210 (3000)	250 (3600)	210 (3000)	250 (3600)	250 (3600)
HYDRAULIC FLUID REQUIREMENTS									
Viscosity	cSt	10-200 / optimum 25-35							
Temperature *	°C (°F)	max. 70 (158)							
Filter ratio	µm	25 or better							
Cooling capacity requirement	kW	2	2	3	4	4	6	5	6
PUMPING FLUID INTAKE REQUIREMENTS									
Suction head max	m (ft)	3 (9.8)							
Feed pressure	bar (psi)	-0,3...16 (-43.5...232)							
Water filter	mesh	80 or better							
OVERALL DIMENSIONS									
Length	mm (in)	160 (6.3)	160 (6.3)	170 (6.7)	175 (6.9)	140 (5.5)	240 (9.4)	195 (7.7)	175 (6.9)
Width	mm (in)	245 (9.6)	245 (9.6)	280 11.0)	345 (13.6)	290 (11.4)	330 (13.0)	314 (12.2)	400 (15.7)
Height	mm (in)	165 (6.5)	155 (6.1)	185 (7.2)	250 (9.8)	175 (6.9)	175 (6.9)	197 (7.8)	270 (10.6)
Weight	kg (lbs)	8 (17.6)	16 (35.2)	18 (39.6)	31 (68.3)	22 (48.5)	28 (61.7)	26 (57.3)	35 (77.2)

Gallons are U.S. liquid gallons

* READ CHAPTER "10. TECHNICAL SPECIFICATIONS"



HIGH PRESSURE WATER PUMPS TECHNICAL SPECIFICATIONS

		HPW 320 /75-125	HPW 800 /30-140	HPW 1600 /15-140	HPW 1000 /30-140	HPW 360 /220-360	HPW 300 /300-350	HPW 1200 /100-440
DISCHARGE CHARACTERISTICS								
Pumping fluid flow max.	l/min (gpm)	75 (19.8)	30 (7.9)	15 (4.0)	30 (7.9)	220 (58.0)	300 (79.2)	100 (26.4)
Pressure max.	bar (psi)	3200 (4600)	800 (11600)	1600 (23200)	1000 (14500)	360 (5200)	300 (4300)	1200 (17400)
Power	kW	40	40	40	50	132	150	200
Water/hydraulic pressure ratio		1,5	4	7,87	4	1,5	1,06	4
HYDRAULIC CONNECTIONS								
Pressure line	P	BSP 3/4"	BSP 3/4"	BSP 3/4"	BSP 3/4"	SAE 6000 1 1/4"	SAE 6000 1 1/4"	SAE 6000 1 1/4"
Return line	T	BSP 3/4"	BSP 3/4"	BSP 3/4"	BSP 3/4"	SAE 6000 1 1/4"	SAE 6000 1 1/4"	SAE 6000 1 1/4"
Service line	CMP	-	BSP 1/8"	BSP 1/8"	BSP 1/8"	BSP 1/8"	BSP 1/8"	BSP 1/8"
Outlet line	WP	BSP 1/2"	BSP 3/8"	HP 1/4"	MP 9/16"	SAE 6000 1" (BSP 3/4")	SAE 6000 1" (BSP 3/4")	MP 3/4"
Intake line	S	BSP 1 1/4"	BSP 3/4"	BSP 1/2"	BSP 3/4"	SAE 3000 2"	SAE 3000 2"	SAE 3000 2"
HYDRAULIC POWER REQUIREMENTS								
Oil flow max.	l/min (gpm)	125 (33.0)	140 (37.0)	140 (37.0)	140 (37.0)	360 (95.0)	350 (92.5)	440 (116.0)
Operating pressure	Δp. bar (psi)	240 (3500)	210 (3000)	230 (3300)	260 (3800)	250 (3600)	350 (5100)	300 (4300)
Pressure max.	bar (psi)	250 (3600)	210 (3000)	230 (3300)	280 (4100)	250 (3600)	350 (5100)	350 (5100)
PUMPING FLUID REQUIREMENTS								
Suction head max	m (ft)	3 (9.8)	2 (6.5)	-	-	3 (9.8)		-
Feed pressure	bar (psi)	-0,3...16 (-43.5...232)	-0,2...16 (-29...232)	1...16 (14.5...232)	5...20 (72.5...290)	-0,3...16 (-43.5...232)		1...16 (14.5...232)
Water filter	mesh	80 or better		625 or better		80 or better		625 or better
HYDRAULIC FLUID REQUIREMENTS								
Viscosity	cSt	10-200 / optimum 25-35						
Temperature *	° C (° F)	max. 70 (158)						
Filter ratio	µm	25 or better						
Cooling capacity requirement	kW	6	6	6	8	25	30	35
OVERALL DIMENSIONS								
Length	mm (in)	250 (9.8)	195 (7.6)	195 (7.6)	168 (6.6)	270 (10,6)	270 (10,6)	265 (10.4)
Width	mm (in)	344 (13.5)	340 (13.3)	405 (15.9)	379 (15.6)	745 (29,3)	745 (29,3)	915 (36)
Height	mm (in)	282 (11.1)	195 (7.6)	160 (6.3)	194 (7.6)	360 (14,2)	360 (14,2)	350 (13.8)
Weight	kg (lbs)	32 (70.4)	39 (85.9)	36 (79.3)	39 (85.9)	170 (374,7)	170 (374,7)	177 (390.2)

Gallons are U.S. liquid gallons

* READ CHAPTER "10. TECHNICAL SPECIFICATIONS"



Menotie 3
FI-33470 Ylöjärvi, Finland
tel: +358 3 3488 200
info@DYNASET.com

Gensco Equipment | 1-800-268-6797 | www.genscoequip.com | info@genscoequip.com



ELECTRICITY

HG Hydraulic Generator
HGV POWER BOX Variable Hydraulic Generator System
HGV Variable Hydraulic Generator System
HWG Hydraulic Welding Generator
HGG Hydraulic Ground Power Generator



HIGH PRESSURE WATER

HPW Hydraulic High Pressure Water Pump
HPW Hydraulic Power Washer
KPL High Pressure Street Washing Unit
HPW-DUST High Pressure Dust Suppression System
PPL High Pressure Pipe Cleaning Unit
HPW-FIRE High Pressure Firefighting System
FP Fire Fighting Piercing Kit
HDF Hydraulic Drilling Fluid Pump
JPL High Pressure Bin Washing System
HSP Hydraulic Submersible Pump



COMPRESSED AIR

HK Hydraulic Piston Compressor
HKL Hydraulic Rotary Vane Compressor
HKR Hydraulic Screw Compressor



MAGNET POWER

HMG PRO Hydraulic Magnet Generator
MAG Lift Magnet
HMAG PRO Hydraulic Magnet



VIBRATION

HVB Hydraulic Vibration Pump
HVD Hydraulic Directional Vibra
HVC Hydraulic Vibration Compactor
HRC Hydraulic Reversal Cylinder



POWER BOOSTING

HPI Hydraulic Pressure Intensifier
HPI-C Hydraulic Pressure Intensifier for Cylinder



KNOW-HOW

Hydraulic Power Take-off (PTO)
Hydraulic Power Unit Technology
HEU Hydraulic Expansion Unit
HRU Hydraulic Rescue Units
De-Icing Technology
Installation Valves
HHK Hydraulic Grinder
HV/HVY Hydraulic Winch / Winch Unit

