

**TRY BEFORE
YOU BUY**

TESTING LAB



- Choose the most suitable equipment.
- Test your own material.
- Touch the result with your own hands.

SINCRO 530 mill

GRANULATOR WITH TURBO MILL

This range of granulators is designed to process any type of cable, electric, electronic, rigid or flexible and to separate copper and/or aluminum from the insulating material, provided it is free from iron. The metal from rigid cables is separated through the zig zag, while lighter material is conveyed to the TURBO MILL for a further reduction, improving the quality of separation and reaching a purity level of 99,9%

Production up to 600 kg/h input material, variable depending on the material being processed.

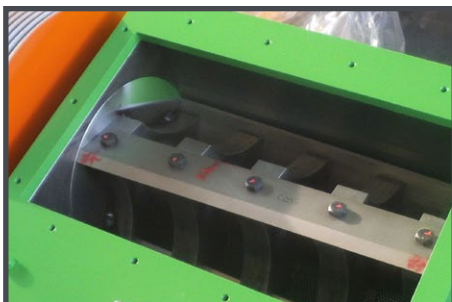
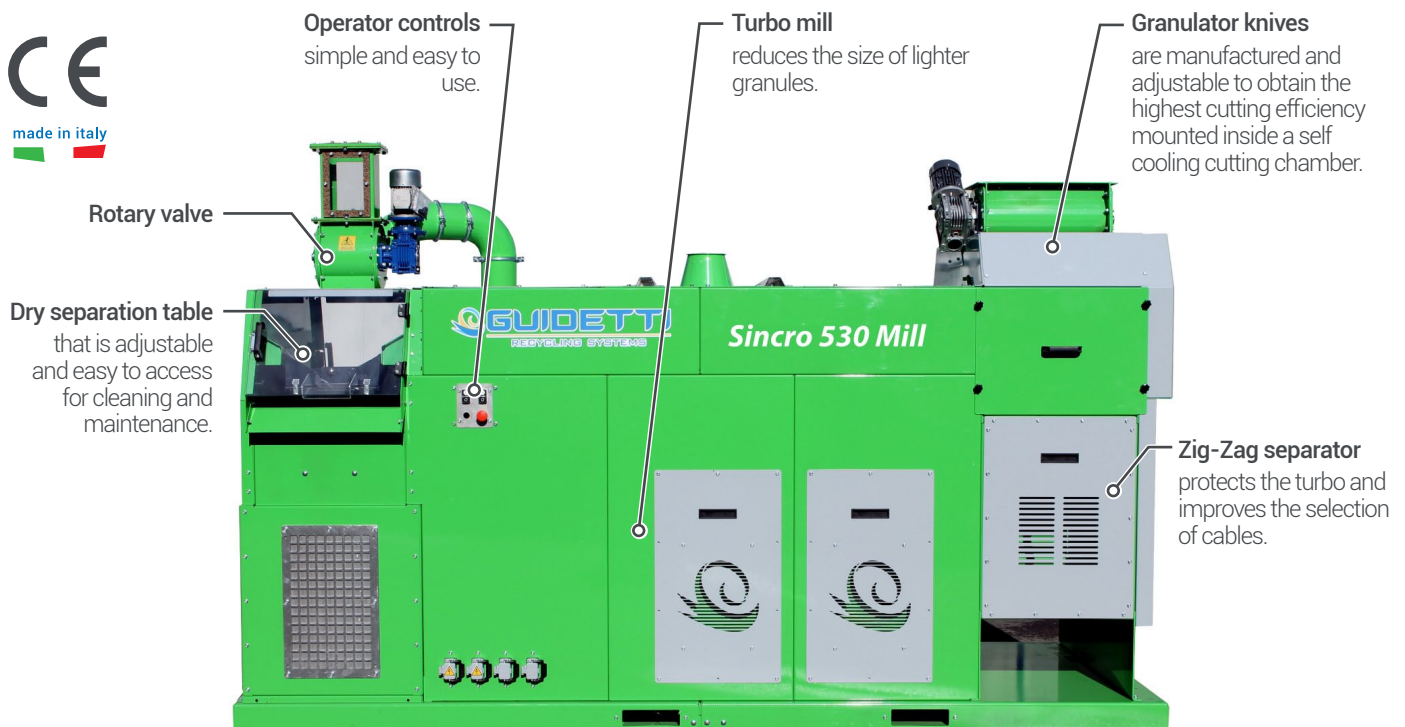

Cutting chamber

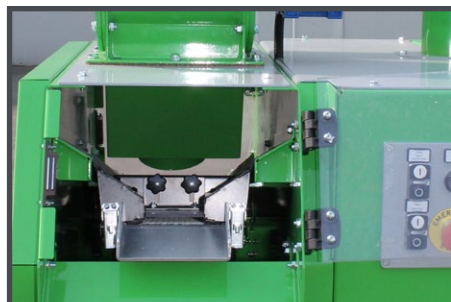

Easy maintenance



Manufactured in accordance to CE rules

EXAMPLES OF INPUT MATERIALS



EXAMPLES OF OUTPUT MATERIALS



TECHNICAL SPECIFICATIONS

- Feeding: **Automatic or Manual**
- Rotor diameter: **305 mm**
- Number of rotating blades: **3**
- Number of fixed blades: **2**
- Screen sizes: **Ø 2-3-4-5-6-8-10 mm**
- Drive type: **V- belts**
- Installed power: **53 kW - 103 A**
- Voltage (standard): **400 V - 50 Hz**
- Separation tables: **60µ up to 200µ screen**
- Total weight: **2700 kg**
- Noise level (as per sample test): **86 db(A)**

PRODUCTION RATES

Input production rates are dependent on material input type and the screen size. The combination with the pre-shredder PMG improves its performance, reduces wearing out of components since iron parts are separated by the magnet installed on the conveyor, and reduces manpower.

INPUT MATERIAL CAPABILITIES OF UNSHREDDED CABLE

- Flexible copper cable up to: **Ø45-50 mm**
- Rigid copper cable up to: **Ø35-40 mm**
- Aluminium cable up to: **Ø38-42 mm**

OPTIONALS

- Rotary valve.
(To ensure even feeding)
- Powder feed system.
(For oily, sticky adhesive materials powder dosing system)
- Electronic connection.
(For automatic operation with the pre-shredder)
- Dust collection.
- Extended warranty.

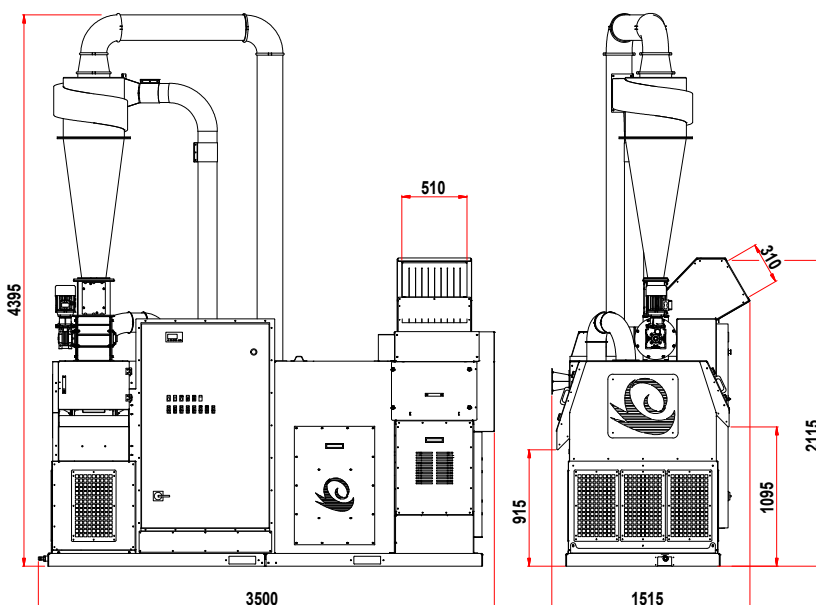

PRODUCTION COMPARATIVE GRAPHIC FOR MACHINE RANGE

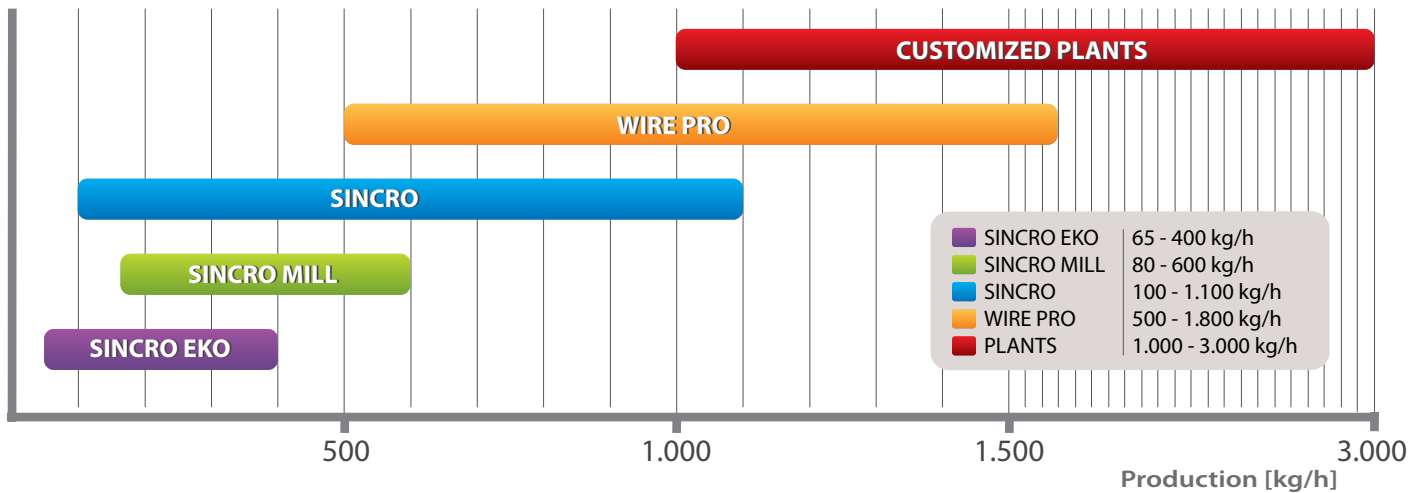

WHY CHOOSE SINCRO 530 MILL

- Highest metal recovery rate with guarantee of constant purity.
- Best price/quality ratio.
- Rapid return of the investment.
- High resale value maintained over time.
- Compact, the perfect solution for small space.
- Ecological with low energy consumption and low noise level.
- Wide range of material that can be recycled.
- Easy to use and maintain.
- Fast and reliable service by factory trained technicians.

COMBINATIONS

All Sincro granulators can be combined to other Guidetti products to increase the production and quality:

- Pre-Shredder series PMG.
- Conveyor belt.
(For the feeding of machines or to collect separated materials)
- Metal dust recovery system.
- Magnetic separator.



WARRANTY EXTENTION

"YOU WORK WE CARE"

Warranty extensions can be purchased for up to 24-36 months from date of shipment. Extended warranty covers the replacement of parts that are defective. Wear items are excluded from all warranties. A yearly visit by a factory trained technician (2 or 3 depending on the extension purchased) will be made to verify the general condition of the equipment.



GUIDETTI SRL
Via Salvi, 1
44045 Renazzo (FE), ITALIA
Piva: 01460390386
Tel: +39 051 6858511
info@guidettisrl.com

guidettisrl.com



GUIDETTI USA LLC
180 Enterprise Boulevard SW
Atlanta GA 30336, U.S.A.
Ph. +1 770 9548780
info@guidettiusa.com

guidettiusa.com