



TRANSFORMER

MULTI KIT

THE **MULTI KIT MKZ SERIES**, WITH ITS QUICK CHANGING SYSTEM, IS A VERSATILE TOOL THAT IS ABLE TO FACE DIFFERENT WORKING CONDITIONS, WITHOUT CHANGING THE MAIN FRAME.

THANKS TO ITS INNOVATIVE AND QUICK HYDRAULIC CHANGING SYSTEM IT IS POSSIBLE TO REPLACE AND COUPLE DIFFERENT DEMOLITION KITS, WITHOUT REMOVING THE STRUCTURAL PINS BY HAND.



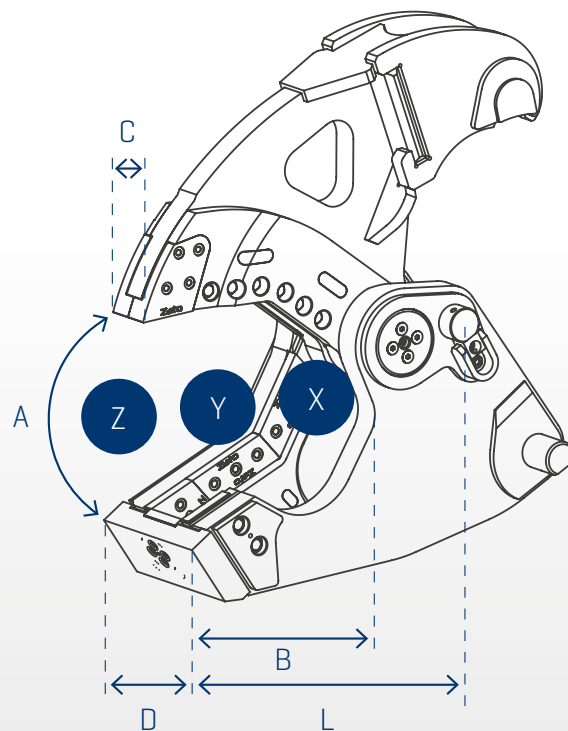
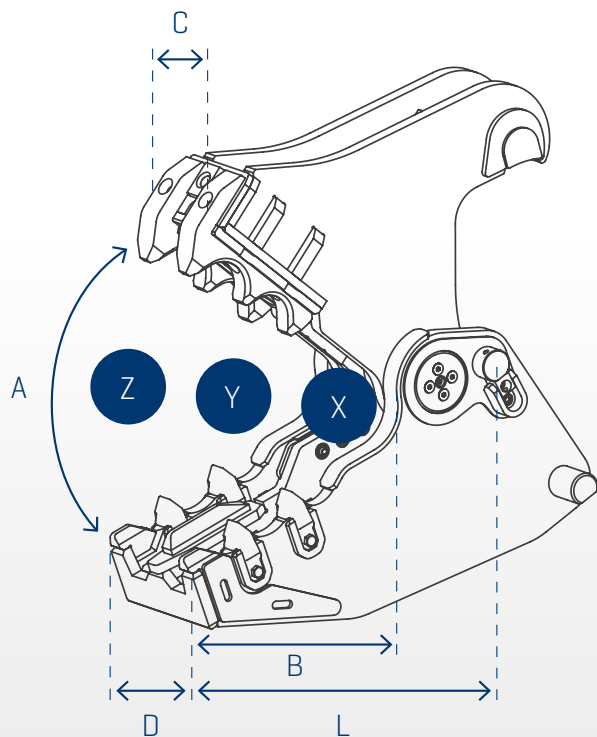

TECHNICAL DATA		MKZ + PULVERISER KIT			MKZ + SHEAR KIT		
		MKZ15	MKZ20	MKZ30	MKZ15	MKZ20	MKZ30
Excavator weight	t	18-26	24-38	38-52	18-26	24-38	38-52
Total weight MKZ	Kg	1900	2500	3250	1900	2400	3100
A	mm	730	900	970	430	480	510
B	mm	710	800	870	535	575	600
C	mm	270	300	370	120	125	130
D	mm	400	450	550	365	390	440
L	mm	970	1070	1200	820	885	900
Force at tip Z	t	70	90	115	90	135	170
Central force Y	t	110	140	180	180	270	320
Force at blade X	t	230	260	315	410	580	750
Blade length	mm	200	240	240	520	560	600
Operating pressure	bar	320-380	320-380	320-380	320-380	320-380	320-380
Oil flow	l/min	200-250	250-300	250-350	200-250	250-300	250-350
Type of rotation		360° Hyd.	360° Hyd.	360° Hyd.	360° Hyd.	360° Hyd.	360° Hyd.
Rotation pressure	bar	140	140	140	140	140	140
Rotation flow	l/min	15	15	15	15	15	15
Rebar	mm	35	40	50	50	60	70

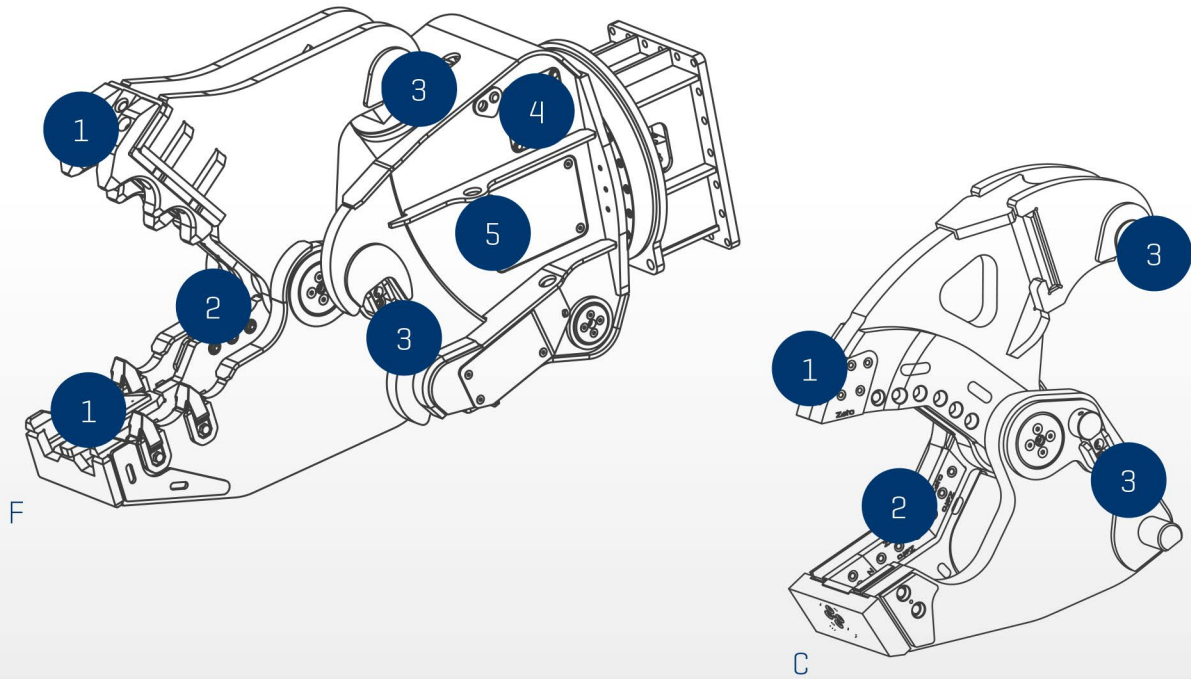

SPECIFICATIONS		MKZ + PULVERISER KIT	MKZ + SHEAR KIT
Cylinder fittings	SAE	3/4"	3/4"
Rotation fittings	GAS	1/2"	1/2"
Speed valve		YES	YES
Interchangeable parts		Teeth + plate	Blade

KEY FEATURES

1 - Interchangeable parts:
All parts subjected to wear can be replaced to restore the efficacy of the tool to 100%



2 - Blade with 4 profiles:
The blade is large and it can be turned to refurbish the cutting profile.



3 - System of change:
The pin remains into the cylinder.



4 - Speed valve.



5 - Compact:
Small-sized, excellent visibility during maneuver.

Multi kit length
1230 mm

Since 1919



GENSCO AMERICA, INC **ACROSS USA 800 268-6797**
5307 Dividend Dr., Decatur, Georgia 30035 • Tel: 770 808-8711 • Fax: 770 808-8739

GENSCO EQUIPMENT (1990) Inc
53 Carlaw Ave., Toronto, Canada M4M 2R6 • Tel: 416 465-7521 • Fax: 416 465-4489
email: info@genscoequip.com • www.genscoequip.com

