

**USER MANUAL**  
**HYDRAULIC MAGNET GENERATOR**



HMG/CMG PRO 3kW  
HMG/CMG PRO 6kW  
HMG/CMG PRO 10kW  
HMG/CMG PRO 12kW

HMG/CMG PRO 15kW  
HMG/CMG PRO 20kW  
HMG/CMG PRO 30kW  
HMG/CMG PRO 40kW



## Congratulations!

You have just purchased DYNASET hydraulic equipment!

The equipment allows you to maximize the productivity and efficiency of your mobile machine. Read this User Manual before using your new equipment. It contains important information that will help you to take the full advance of the technical features available in your equipment.

Please contact us for any feedback you might have on our products. Your feedback is important to us for improving our products and customer service.

We are constantly developing and releasing new innovations. Please visit on our website and social media channels for the latest news and updates.

[www.dynaset.com](http://www.dynaset.com)  
[info@dynaset.com](mailto:info@dynaset.com)

 [www.facebook.com/dynaset](https://www.facebook.com/dynaset)  
 [www.youtube.com/dynasetoy](https://www.youtube.com/dynasetoy)

[www.genscoequip.com](http://www.genscoequip.com)  
[info@genscoequip.com](mailto:info@genscoequip.com)

 [www.facebook.com/genscoequip](https://www.facebook.com/genscoequip)  
 [www.youtube.com/genscoequip](https://www.youtube.com/genscoequip)

Subscribe to our newsletter. Follow the QR code!





<b>1. GENERAL</b>	<b>9</b>
1.1. PRODUCT INFORMATION.....	9
1.2. PRODUCT IDENTIFICATION KEY.....	9
1.3. TYPE PLATE .....	10
1.4. HMG/CMG PRO'S LINE-UP.....	10
1.5. MAIN COMPONENTS OF HMG/CMG PRO.....	12
1.6. IP (Ingress Protection) CLASSIFICATION.....	13
<b>2. SAFETY</b>	<b>15</b>
2.1. SAFETY PRECAUTIONS.....	15
2.2. SAFETY EQUIPMENT.....	16
2.3. OPERATING SAFETY.....	17
2.4. MAINTENANCE SAFETY.....	18
2.5. WARNING LABELS.....	18
<b>3. OPERATING PRINCIPLES</b>	<b>21</b>
3.1. OPERATING DESCRIPTION.....	21
3.2. PERFORMANCE OF AUTOMATIC RPM-CONTROL.....	22
3.3. PRESSURE POWER RATIO.....	22
3.4. MAGNETIZATION AND DEMAGNETIZATION.....	23
3.5. THE DISPLAY OF THE MAGNET GENERATOR.....	23
<b>4. INSTALLATION</b>	<b>25</b>
4.1. BEFORE INSTALLATION.....	25
4.1.1. HYDRAULIC SYSTEM OF A BASE MACHINE.....	25
4.1.2. DYNASET VALVES.....	34
4.2. INSTALLING DYNASET HYDRAULIC PRODUCT.....	35
4.2.1. PLACING DYNASET HYDRAULIC PRODUCT.....	35
4.2.2. INSTALLING DYNASET VALVES.....	36
4.2.3. CONNECTING HYDRAULIC HOSES.....	36
4.2.4. HYDRAULIC FLUIDS.....	37
4.3. INSTALLATION OF THE HMG/CMG PRO.....	38
4.3.1. PLACEMENT.....	38
4.3.2. GROUNDING.....	39
4.3.3. IP CODE REQUIREMENTS.....	40
4.4. OUTPUT VOLTAGE INSPECTION AT START-UP.....	40
4.5. HGM/CMG PRO CONTROL CARD SETTINGS.....	42
4.5.1. SETTINGS FOR SINGLE/MASTER CONTROL CARD OPERATION.....	42



4.5.2.	SETTINGS FOR MULTIPLE CONTROL CARD OPERATION.....	43
4.6.	WIRE SIZES AND WIRING FOR THE HMG/CMG CABLES.....	45
4.7.	OPTIONAL ELECTRIC INSTALLATIONS.....	46
4.8.	MAGNET COMPATIBILITY TABLE.....	47
4.8.1.	MEASURING HMG/CMG PRO RESISTANCE.....	48
4.8.2.	MEASURING MAGNET'S RESISTANCE.....	48
<b>5.</b>	<b>OPERATION</b>	<b>49</b>
5.1.	OPERATING THE HMG/CMG PRO.....	49
5.2.	POWER REDUCTION MODE.....	50
5.3.	DISPLAY OF THE HMG/CMG PRO.....	51
5.4.	HOW TO STOP THE HMG/CMG PRO.....	52
5.5.	OVERHEAT AND OVERLOAD SITUATION.....	52
5.6.	AMBIENT TEMPERATURE.....	52
<b>6.</b>	<b>MAINTENANCE</b>	<b>55</b>
6.1.	MAINTENANCE INTERVALS.....	55
6.2.	HYDRAULIC FLUIDS.....	55
6.3.	CLEANING THE HMG/CMG PRO.....	56
6.4.	REPLACING CONTROL CARD.....	57
6.5.	OUTPUT VOLTAGE ADJUSTING.....	59
6.6.	TROUBLESHOOTING.....	63
<b>7.</b>	<b>MANUFACTURER'S LIMITED WARRANTY</b>	<b>67</b>
<b>8.</b>	<b>PRODUCT DISPOSAL</b>	<b>69</b>
<b>9.</b>	<b>DECLARATION OF CONFORMITY</b>	<b>71</b>
<b>10.</b>	<b>TECHNICAL SPECIFICATIONS</b>	<b>73</b>

Picture 1: HMG/CMG PRO Identification key.....	9
Picture 2: Type plate.....	10
Picture 3: HMG PRO models line-up.....	11
Picture 4: CMG PRO model.....	12
Picture 5: Main components of HGM PRO.....	12
Picture 6: Main components of CMG PRO.....	13
Picture 7: HMG PRO 10 operating principle.....	21
Picture 8: Automatic RPM-control.....	22
Picture 9: Pressure/Power chart.....	22
Picture 10: Open centre hydraulic system with load sensing variable displacement pump.....	26
Picture 11: Connection figure for open centre hydraulic system with load sensing variable displacement pump.....	27
Picture 12: Closed centre hydraulic system with load sensing variable displacement pump.....	28
Picture 13: Connection figure for closed centre hydraulic system with load sensing variable displacement pump.....	29
Picture 14: Open centre hydraulic system with constant displacement pump.....	30
Picture 15: Connection figure for open centre hydraulic system with fixed displacement pump.....	31
Picture 16: Open centre hydraulic system with fixed displacement pump.....	32
Picture 17: Connection figure for hydraulic system with fixed displacement pump at fixed rotation speed.....	33
Picture 18: LSV Load sensing valve.....	34
Picture 19: PV-SAE Priority valve.....	34
Picture 20: VKV Free flow valve.....	35
Picture 21: Placing dynaset product.....	35
Picture 23: Installing hydraulic hoses.....	36
Picture 22: Hydraulic flow at nominal.....	36
Picture 24: Base machine's pumps.....	37
Picture 25: Return line (T) pressure must be under 5 bars.....	37
Picture 26: Placement of the HMG/CMG PRO hydraulic magnet generator.....	38
Picture 27: Grounding the HMG/CMG PRO hydraulic magnet generator.....	39
Picture 28: IP classification requirements.....	40
Picture 29: Starting HMG/CMG PRO.....	41
Picture 30: Adjusting voltage.....	41
Picture 31: Location of the DIP switches on the control card.....	42
Picture 32: Single/MASTER card DIP switches.....	42
Picture 33: MASTER and SLAVE card order.....	43
Picture 34: Multiple card DIP switches.....	44
Picture 35: Wiring for the cable from the generator to the magnet.....	45
Picture 36: Protected booms socket and 20m cable to the magnet generator.....	46
Picture 37: DYNASET MAG.....	47
Picture 39: Measuring HMG/CMG PRO's resistance.....	48
Picture 40: Measuring resistance from the magnet.....	48
Kuva 41: Hydraulic operation method.....	49
Picture 42: Operating the magnetization by controlling magnet generator's magnetizing voltage.....	50
Picture 43: Operating in the reduction mode.....	51
Picture 44: Generator's main steps and voltage sequence's on the display.....	51
Picture 45: O.HEA on the Display.....	52
Picture 46: Power take off in higher temperatures.....	53
Picture 47: Cleaning the HMG/CMG PRO.....	56



Picture 48: Removing control card.....	58
Picture 49: Apply the thermal paste.....	58
Picture 50: Installing the control box cover.....	59



HYDRAULIC MAGNET GENERATORS  
TABLE OF PICTURES

## 1. GENERAL

This manual contains general information about the assembly, installation, operation and maintenance of the DYNASET HMG/CMG PRO hydraulic magnet generators.

### ATTENTION!

Read this operating manual before installation, use or maintenance of the HMG/CMG PRO hydraulic magnet generator, to ensure proper, installation, handling, operation and maintenance right from the beginning. Pay attention to the warning and safety instructions. READ CHAPTER "2. SAFETY" for more information.

### 1.1. PRODUCT INFORMATION

HMG/CMG PRO hydraulic magnet generators are compact and integrated all-in-one units, designed especially for mobile installation. HMG/CMG PROs use hydraulic power source to operate and produce high quality electricity for magnetization.

### 1.2. PRODUCT IDENTIFICATION KEY

HMG/CMG PROs are identified by identification key. The key can be found from the products type plate which is attached on to HMG/CMG PRO side.

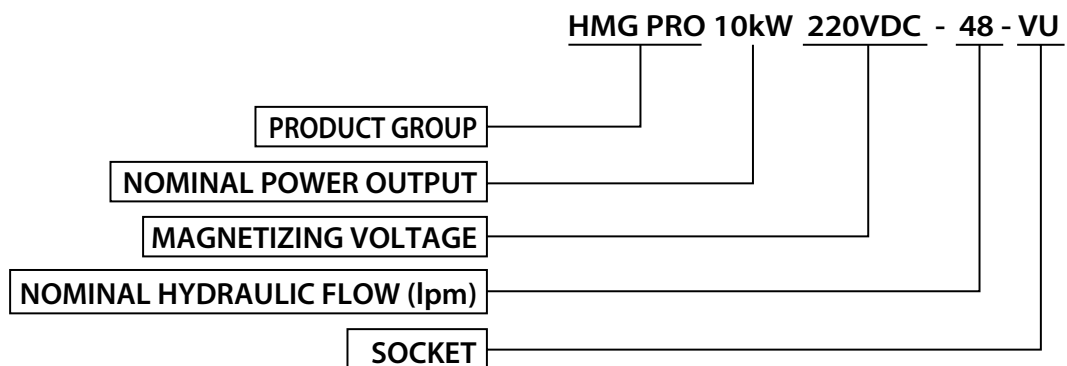

Picture 1: HMG/CMG PRO Identification key.

**PRODUCT GROUP**

Presents the product category, in this case HMG/CMG PRO Hydraulic magnet generators.

**NOMINAL POWER OUTPUT**

Generator's theoretical power output in kW.

**MAGNETIZING VOLTAGE**

Generator's output voltage for magnetizing is 220 VDC.

**NOMINAL HYDRAULIC FLOW**

Theoretical hydraulic flow of the base machine needed to operate the product.

**SOCKET**

Auxiliary power outputs are available for HMG PRO as an option by request.

**1.3. TYPE PLATE**

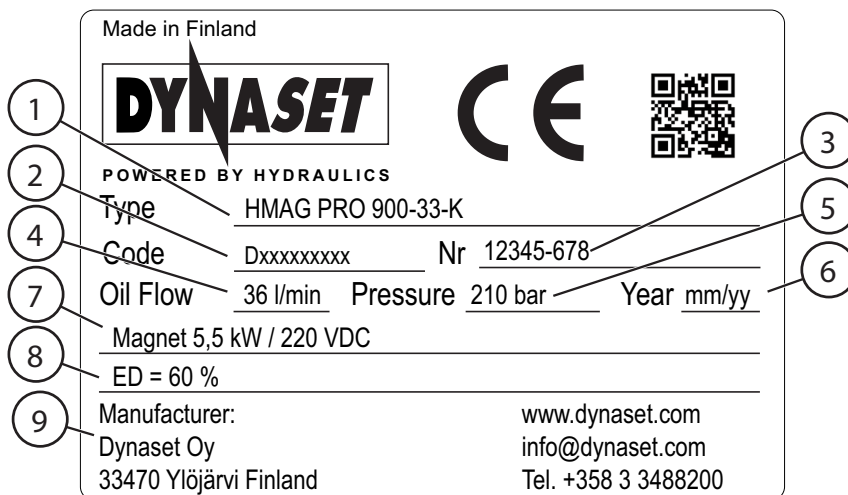

Picture 2: Type plate

- |                               |                                       |
|-------------------------------|---------------------------------------|
| 1. Product identification key | 6. Production month / year            |
| 2. Product code               | 7. Output power / voltage             |
| 3. Serial number              | 8. Generator's control voltage        |
| 4. Minimum hydraulic flow     | 9. Manufacturer's contact information |
| 5. Maximum hydraulic pressure |                                       |

**1.4. HMG/CMG PRO'S LINE-UP**

DYNASET hydraulic magnet generator's come in two main models HMG PRO and CMG PRO.

HMG PRO models are operated through an external control typically from the base machine's cabin. There are two ways you can operate the HMG PRO.

1. Control the magnetization through the HMG PRO control box. In this mode the hydraulic flow is on at all the time and the operator switches magnetization on and off separately.
2. Control the hydraulic flow. In this mode the magnetization starts when the operator turns hydraulic flow ON to the magnet generator.

CMG PRO can only be operated by opening the hydraulic flow to the generator. As the hydraulic flow is opened to the CMG PRO the magnetization begins.

### STANDARD MODELS

DYNASET HMG/CMG PROs come in eight standard models. They vary by their maximum generator power (3-40kW). The models can also be categorized through their looks and appearance into five different categories as shown in the picture 3.

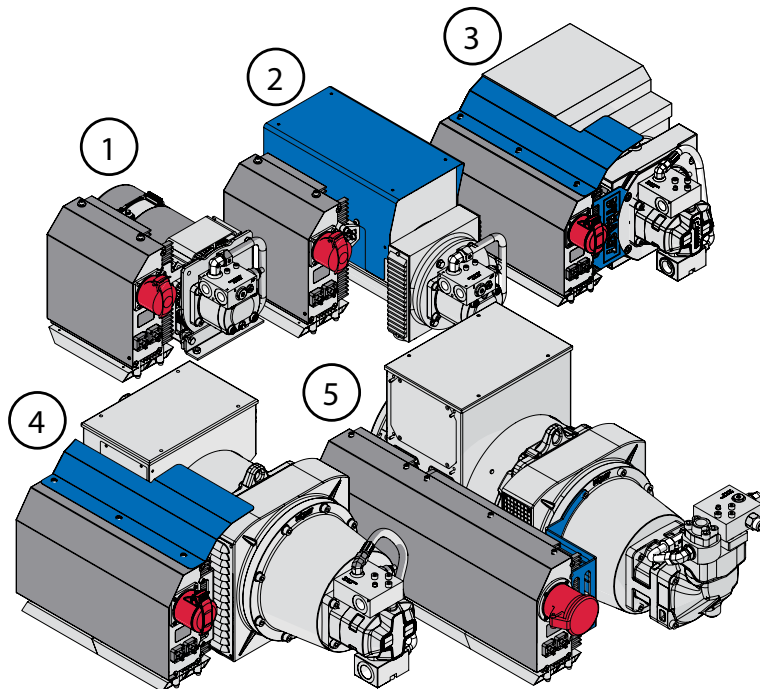

Picture 3: HMG PRO models line-up

- |   |  |
|---|--|
| 1. HMG/CMG 3 kW 220 VDC                           | 4. HMG/CMG 15 kW 220 VDC,<br>HMG/CMG 20 kW 220 VDC |
| 2. HMG/CMG 6 kW 220 VDC,<br>HMG/CMG 10 kW 220 VDC | 5. HMG/CMG 30 kW 220 VDC,<br>HMG/CMG 40 kW 220 VDC |
| 3. HMG/CMG 12 kW 220 VDC                          |  |

CMG models are similar to the HMG PRO models but have cable power outlet instead of socket and no electrical control sockets as shown in the picture 4.

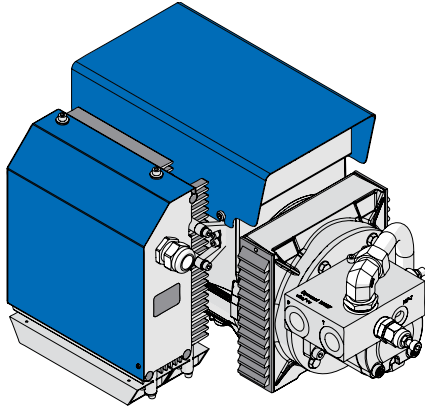

Picture 4: CMG PRO model

## 1.5. MAIN COMPONENTS OF HMG/CMG PRO

### HMG PRO

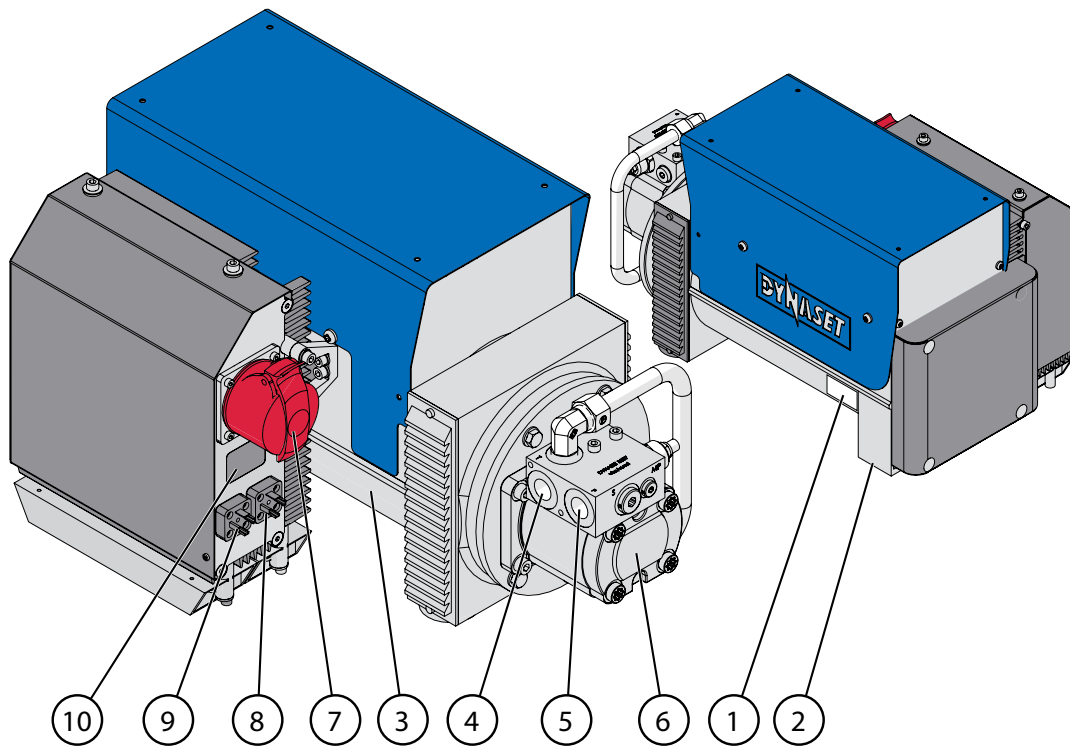

Picture 5: Main components of HGM PRO

- |                                |  |
|--------------------------------|--|
| 1. Type plate <sup>1</sup>     | 6. Hydraulic motor   |
| 2. Serial number <sup>1</sup>  | 7. Electric sockets in HMG PRO/<br>Cable connection in CMG PRO |
| 3. Alternator                  | 8. Solenoid valve  |
| 4. Hydraulic pressure line (P) | 9. Control voltage   |
| 5. Hydraulic return line (T)   | 10. Digital display  |

<sup>1</sup> Place may vary between models

CMG PRO

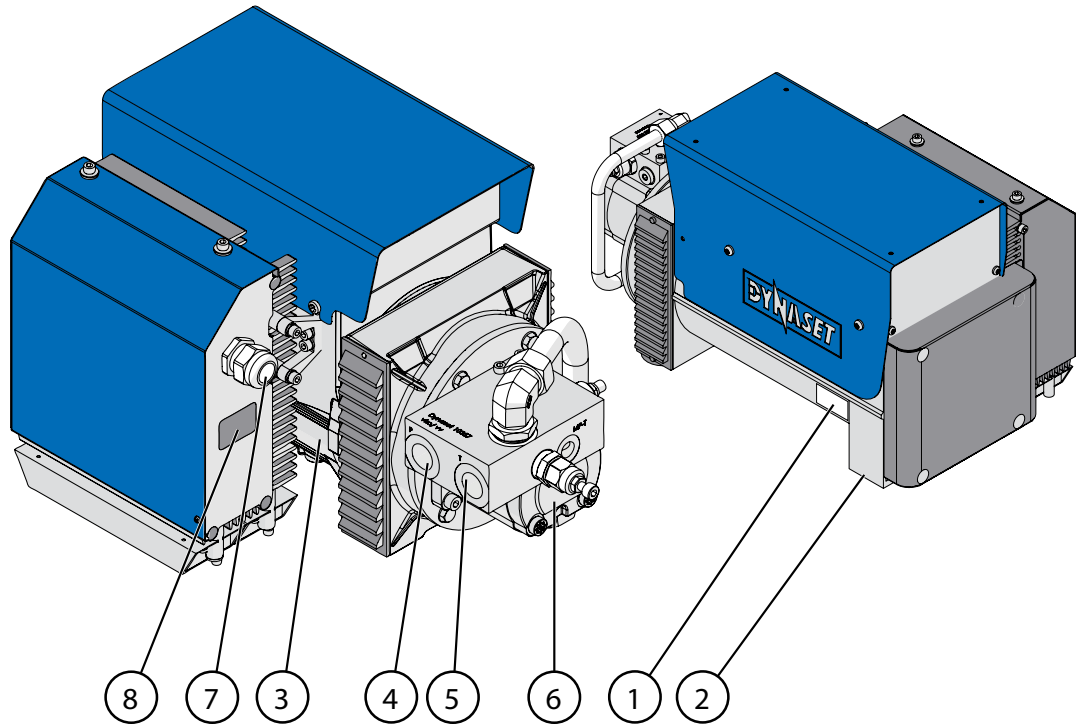

Picture 6: Main components of CMG PRO

- |                                |                              |
|--------------------------------|------------------------------|
| 1. Type plate <sup>1</sup>     | 5. Hydraulic return line (T) |
| 2. Serial number <sup>1</sup>  | 6. Hydraulic motor           |
| 3. Alternator                  | 7. Cable connection          |
| 4. Hydraulic pressure line (P) | 8. Digital display           |

<sup>1</sup>Place may vary between models

**1.6. IP (Ingress Protection) CLASSIFICATION**

HMG/CMG PRO hydraulic generators are IP classified according to the IEC standard 60529 for the degrees of protection of electrical equipment. The protection class of standard HMG/CMG PRO hydraulic generators complies with the specifications of the IP23.

From the IP classification guide you can check your IP class information.

# IP Ingress Protection Classification guide

SOLIDS		WATER	
1	Protected against a solid object greater than 50 mm <sup>3</sup> such as a hand.	1	Protected against vertically falling drops of water.
2	Protected against a solid object with greater than 12.5 mm diameter, such as a finger.	2	Protected against direct sprays of water with up to 15 degrees from vertical.
3	Protected against a solid object with greater than 2.5 mm diameter such as a screwdriver.	3	Protected against direct sprays of water up to 60 degrees from vertical.
4	Protected against a solid object with greater than 1 mm diameter such as a wire.	4	Protected against water sprayed from all directions. Limited ingress permitted.
5	Dust protected. Limited ingress of dust permitted i.e. no harmful deposit.	5	Protected against low pressure jets of water from all directions. Limited ingress permitted.
6	Totally dust protected. No ingress of dust.	6	Protected against strong jets of water from all directions. Limited ingress permitted.
Rating example: <b>IP 23</b>		7	Protected against the effects of immersion in water between 15 cm and 1 m for 30 min.
		8	Protection against the effects of immersion in water under pressure for long periods.
		9	Protection against high pressure, high temperature jets of water from multiple directions.

## 2. SAFETY

### 2.1. SAFETY PRECAUTIONS

 **ATTENTION!**

Operator and maintenance personnel must act in compliance with the laws, regulations and recommendations issued by the local electricity and work safety authorities.

 **ATTENTION!**

All installations and maintenance must be performed according to this manual. All electrical installations and maintenance that is not shown in this manual should only be performed by a qualified electrician.

 **WARNING**

**RISK OF ELECTRIC SHOCK!**

Risk of electric shock. Do not remove any covers when operating. All the repairs must be done by a qualified electrician.

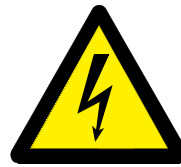

RISK OF ELECTRIC SHOCK.

Operating voltage of the HMG/CMG PRO hydraulic magnet generators is 220 VDC

 **WARNING**

**HIGH PRESSURE OIL!**

Can cause severe injuries. Always wear appropriate clothing and safety equipment.



The hydraulic system is pressurized up to 420 bar.



The pressure in hydraulic circuits of HMG/CMG PRO hydraulic magnet generator is considerably high. Therefore the technical condition of your equipment should be kept under constant observation.

All couplings, valves and hoses should be maintained tight and kept clean. Leaks in the hydraulic system must be fixed immediately to avoid injuries caused by high pressure and oil blowouts.

 **WARNING**

**MAGNETIC FIELD INTERFERENCE**

Magnetic field may interfere and damage electronics nearby. Do not use near medical implants or electronics. Keep safe distance according the magnet manufacturer.



Magnet produces a strong magnetic field that interferes with electronic devices. Do not use electronic devices near the magnet.

---

 **NOTE!**

Technical condition of your machinery and equipment must be subjected to constant surveillance.

---

## 2.2. SAFETY EQUIPMENT

When operating in the immediate vicinity of the HMG/CMG PRO hydraulic magnet generator or its accessories, wear appropriate protective clothing, safety goggles, gloves, ear and eye protection.



### 2.3. OPERATING SAFETY

**WARNING**

**RISK OF BURNS!**

The unit parts and oil can be hotter than 80°C!

Wear personal safety equipment!

**ATTENTION!**  
Maximum load must never be exceeded.

**WARNING**

**DO NOT GET UNDER THE LOAD!**

Danger of getting crushed. Stay clear from the magnet and the base machine's reach. Check base machine's manual for safety area details.

Never get under the magnet when operating. The collected metals might drop due to a failure in the base machine or in the HMG/CMG PRO system. Remember to keep the safe distance and stay outside of the base machines reach.

Ensure also that the magnetic field does not interfere and damage other electrical and electronic equipment and instrumentation. For the duration of using the magnet, switch off and unplug all sensitive electric and electronic units. Such units are e.g. AC-chargers, electronic sensors, control and measurement instruments.

**VAROITUS**

**RISK OF ELECTRIC SHOCK!**

**Do not unplug the magnet cable from the generator when the magnet is powered on!** Unplugging the cable will cause an electric arc that can cause a severe or fatal injury. Always stop the generator and wait for the magnet to discharge before unplugging it from the generator.

RISK OF ELECTRIC SHOCK.

## 2.4. MAINTENANCE SAFETY

 **NOTE!**



When carrying out any maintenance to HMG/CMG PRO hydraulic magnet generator keep the components of the system clean. This is to ensure safe, reliable and longlife operation of your equipment.

 **WARNING**

**RISK OF ELECTRIC SHOCK!**

Wait until the charge of the electric parts is completely discharged before removing any covers.

Stop and wait at least 30 minutes for a proper discharge.

  
  
RISK OF ELECTRIC SHOCK.

Hydraulic system of the base machine should be maintained according to the machine's service program. READ CHAPTER "6.1. Maintenance Intervals" for more information.

Prior to the maintenance, detaching from the base machine or disassembling HMG/CMG PRO hydraulic magnet generator, the hydraulic system of the base machine have to be stopped and the hydraulic circuit depressurized.

## 2.5. WARNING LABELS

Warning labels are included with each main product.

Product recipient is obligated to place warning labels on the DYNASET product. Attach labels to visible and appropriate place on to or close to DYNASET product where it's easily seen. Clean surface with solvent detergent before attaching labels.

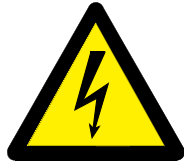

RISK OF ELECTRIC SHOCK



BEWARE THE HOT SURFACE



BEWARE THE MAGNETIC FIELD



RISK OF MEDICAL EQUIPMENT FAILURE



READ OPERATING INSTRUCTIONS



USE EAR PROTECTION AND SAFETY GOGGLES



WEAR GLOVES



WEAR SAFETY BOOTS



HYDRAULIC MAGNET GENERATORS  
SAFETY

### 3. OPERATING PRINCIPLES

#### 3.1. OPERATING DESCRIPTION

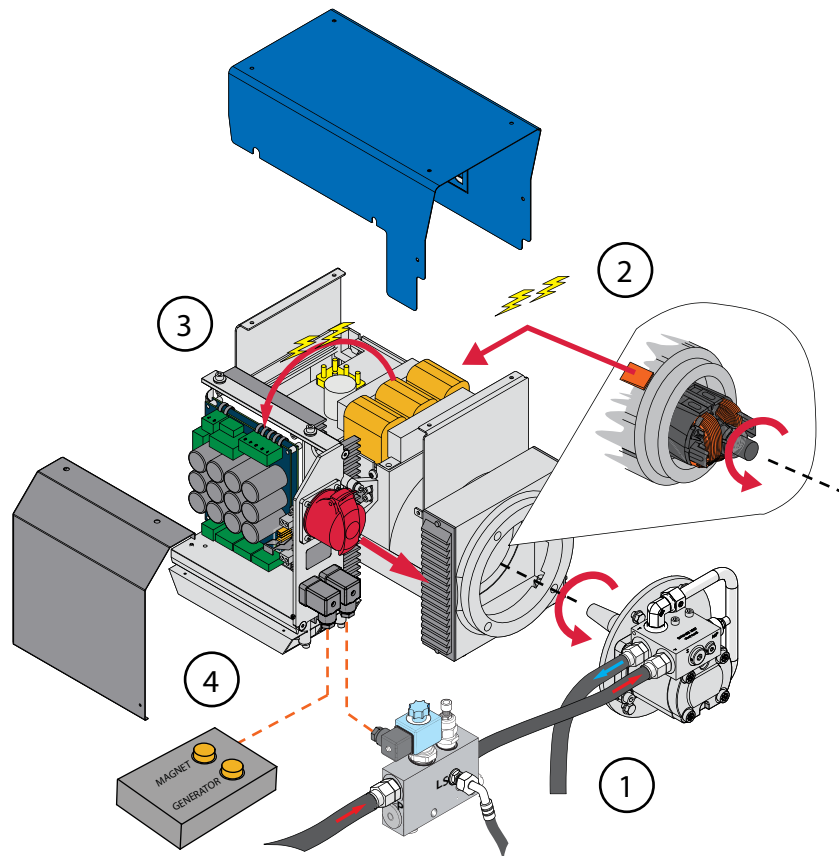

Picture 7: HMG PRO 10 operating principle

1. Starting the HMG/CMG PRO happens by opening the the hydraulic flow to the RPM-valve block. The RPM-valve keeps the flow constant and controls the speed of the hydraulic motor through the RPM-cartridge.
2. Hydraulic motor actuates the alternator's rotor through a direct connection to the rotor. When the rotor spins it produces a changing magnetic flux that generates electricity.
3. From the stator windings the electricity is directed through the distribution box on to the generators control box.
4. When the magnetizing button is pressed on the generator produces 220 VDC to magnetize the magnet.

### 3.2. PERFORMANCE OF AUTOMATIC RPM-CONTROL

The RPM-cartridge maintains rotation speed of the hydraulic motor constant ( $\pm 5\%$ ). Even when incoming hydraulic flow (Q) can vary from minimal flow (Qmin) by exceeding it up to 20-30%, depending on the HMG/CMG PRO's size, the hydraulic motors rpm is kept stable ( $\pm 5\%$ ).

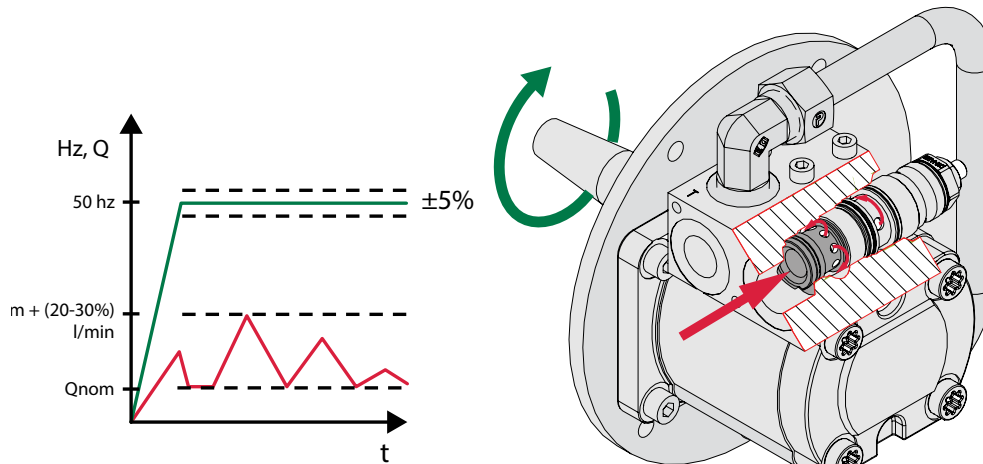

Picture 8: Automatic RPM-control

### 3.3. PRESSURE POWER RATIO

Following chart in picture 9 describes the power to pressure ratio. The chart shows output powers relation to the pressure, when the hydraulic flow Q is kept constant. The best power to pressure ratio is achieved when the pressure is at nominal level, little under the maximum value. READ CHAPTER "10. Technical specifications" for more information of each models nominal pressure.

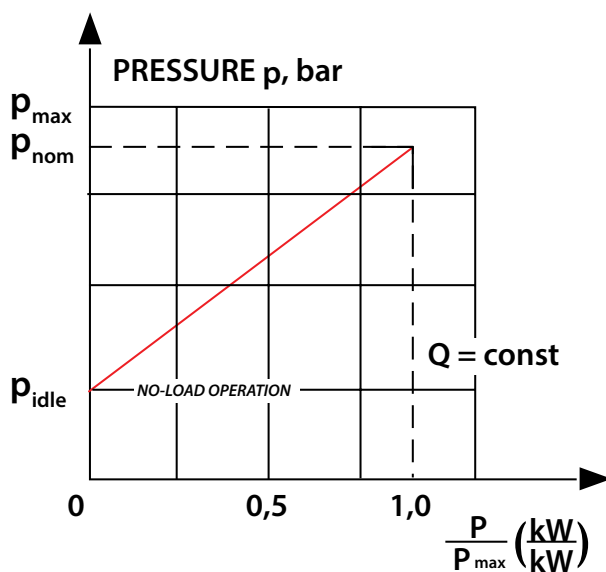

Picture 9: Pressure/Power chart



### **3.4. MAGNETIZATION AND DEMAGNETIZATION**

Magnetization and demagnetization are controlled electronically by the HMG/CMG PRO control unit. The electronic control enables the magnet to demagnetize in 0,8s.

### **3.5. THE DISPLAY OF THE MAGNET GENERATOR**

The display shows the steps of the magnetization, magnetizing voltage and error messages. Magnetization steps are described in READ CHAPTER "5.1. Operating the HMG/CMG PRO" for more information. The error messages are described in READ CHAPTER "6.6. Troubleshooting" for more information.



HYDRAULIC MAGNET GENERATORS  
OPERATING PRINCIPLES

## 4. INSTALLATION

### 4.1. BEFORE INSTALLATION

---

**⚠ ATTENTION!**

Read these instructions before installation of the DYNASET product!

---

#### 4.1.1. HYDRAULIC SYSTEM OF A BASE MACHINE

Base machines have different types of hydraulic systems. The most common hydraulic systems in mobile machinery are:

- Open centre hydraulic system with a Load Sensing variable displacement pump
- Closed centre hydraulic system with a Load Sensing variable displacement pump
- Hydraulic system with a fixed displacement pump
- Hydraulic system with a fixed displacement pump at fixed rotation speed

**Before installing the DYNASET product, find out the type of the hydraulic system of your machine.**

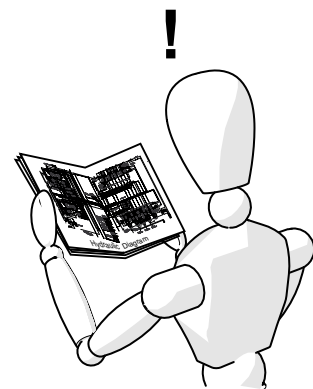
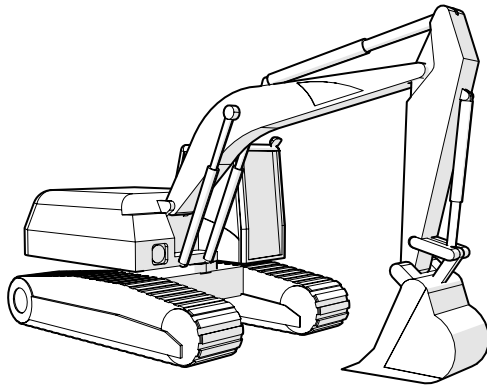

If you are unsure of the hydraulic system, please contact the manufacturer of your base machine.

Next four paragraphs describe the hydraulic systems in more detail.

**OPEN CENTRE HYDRAULIC SYSTEM WITH LOAD SENSING VARIABLE DISPLACEMENT PUMP**

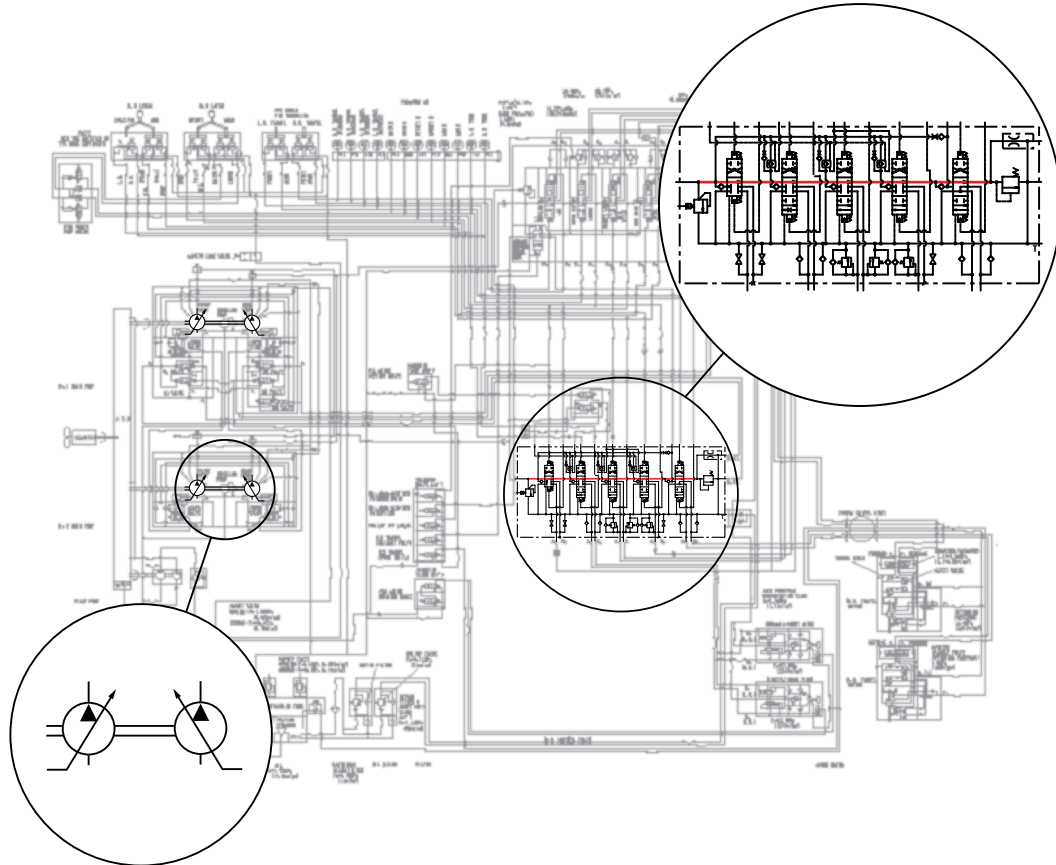

Picture 10: Opencentrehydraulicsystemwithloadensingvariabledisplacementpump

In open centre hydraulic system the flow is returned to tank through the control valves open centre; that is, when the control valve is centered. It provides an open return path to tank and the fluid is not pumped into a high pressure. In variable-displacement pump, the flow rate and output pressure adjusts automatically based on the load of the hydraulic system.

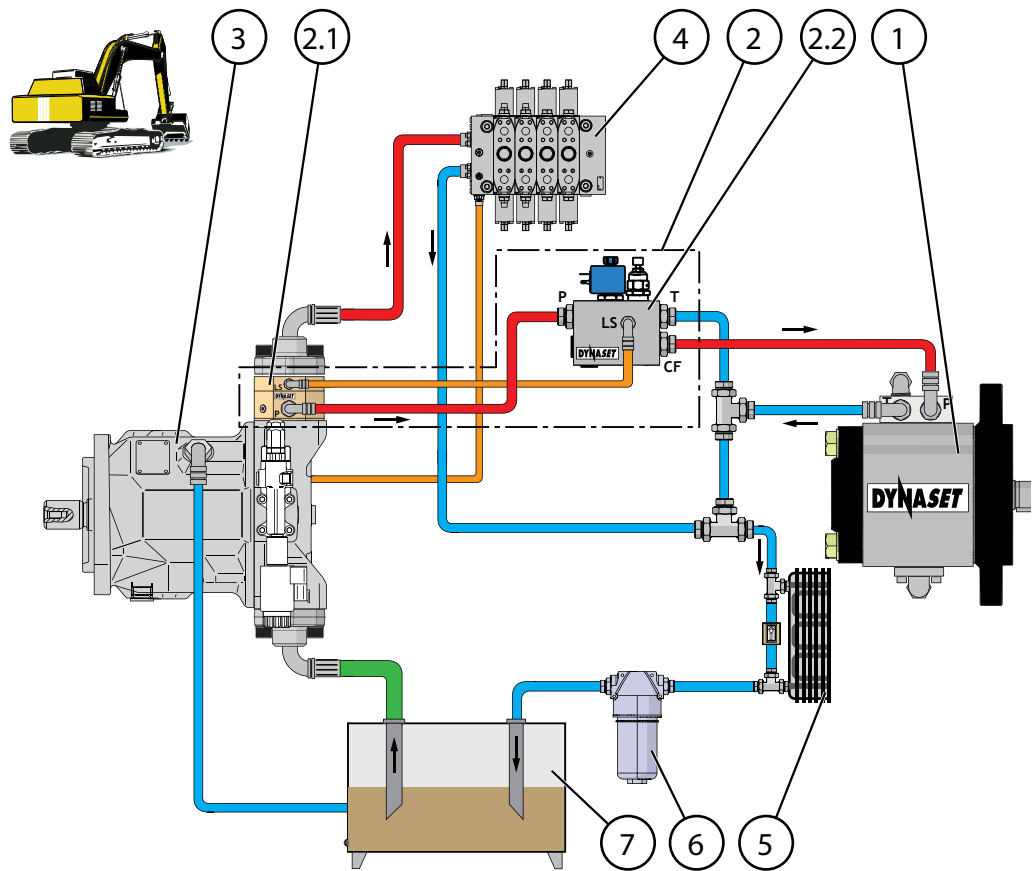

Picture 11: Connection figure for open centre hydraulics system with load sensing variable displacement pump

- |  |   |
|--|---|
| 1. DYNASET hydraulic equipment               | 4. Open centre directional control valves |
| 2. DYNASET Priority valve PV-SAE             | 5. Oil cooler                             |
| 2.1. DYNASET PC-SAE pressure compensator     | 6. Oil filter                             |
| 2.2. DYNASET TSLV Load Sensing valve         | 7. Oil tank                               |
| 3. Base machine's variable displacement pump |   |

**CLOSED CENTRE HYDRAULIC SYSTEM WITH LOAD SENSING VARIABLE DISPLACEMENT PUMP**

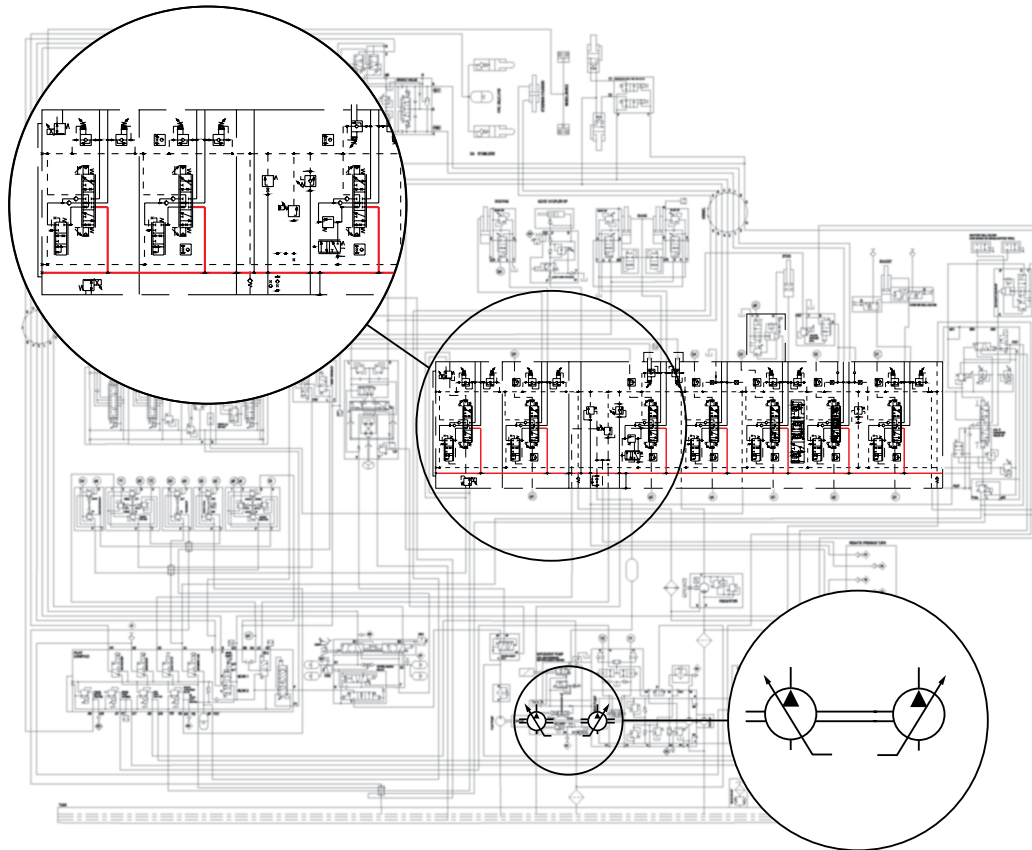

**Picture 12: Closed centre hydraulic system with load sensing variable displacement pump**

In a closed centre hydraulic system the oil flow is stopped from the pump when control valve is centered. The pump can rest when the oil is not required to operate a function. In variable-displacement pump, the flow rate and output pressure adjusts automatically based on the load of the hydraulic system.

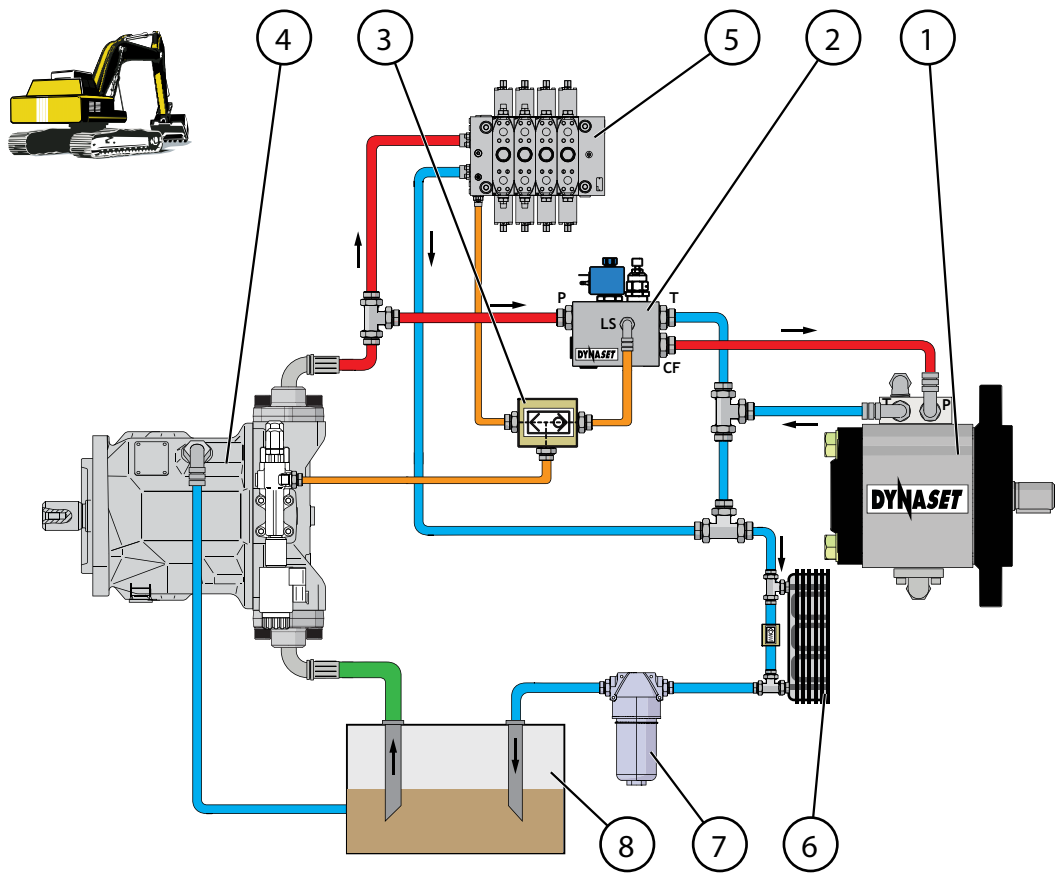

Picture 13: Connection figure for closed centre hydraulics system with load sensing variable displacement pump

- |  |   |
|--|---|
| 1. DYNASET hydraulic equipment               | 5. Closed centre directional control valves |
| 2. DYNASET LSV Load Sensing valve            | 6. Oil cooler                               |
| 3. DYNASET Shuttle valve                     | 7. Oil filter                               |
| 4. Base machine's variable displacement pump | 8. Oil tank                                 |

HYDRAULIC SYSTEM WITH FIXED DISPLACEMENT PUMP

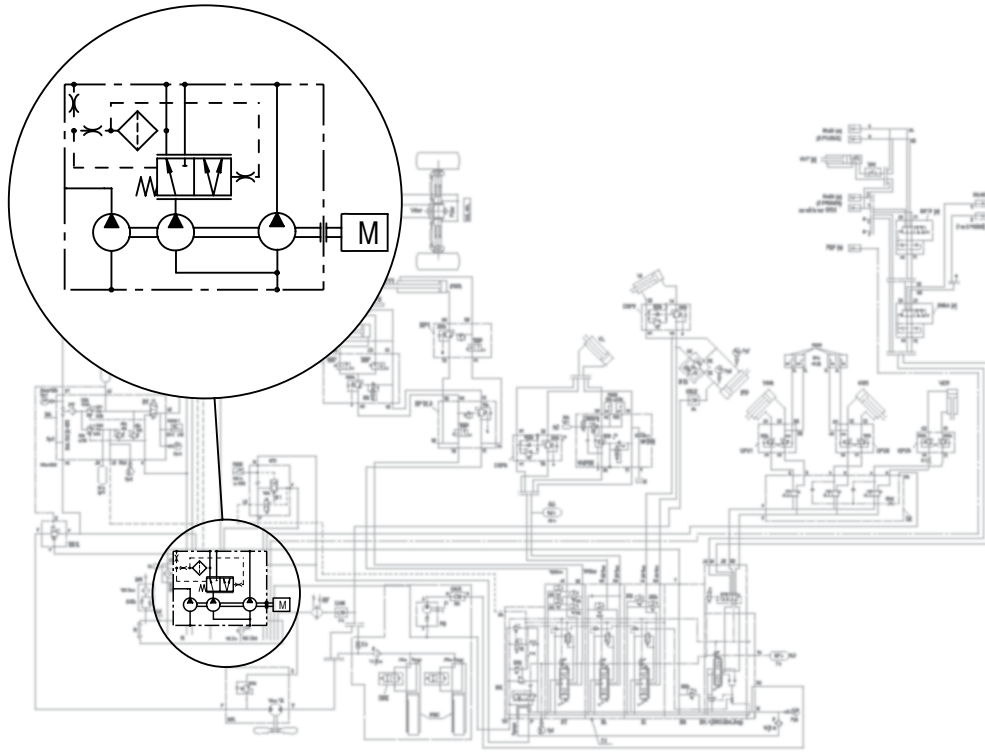

Picture 14: Open centre hydraulic system with constant displacement pump

In hydraulic system which has the fixed displacement pump, the oil flow from the pump is fixed. Every stroke of the hydraulic motor moves the same amount of oil. The output flow is function of the motor's rpm and pump's displacement.

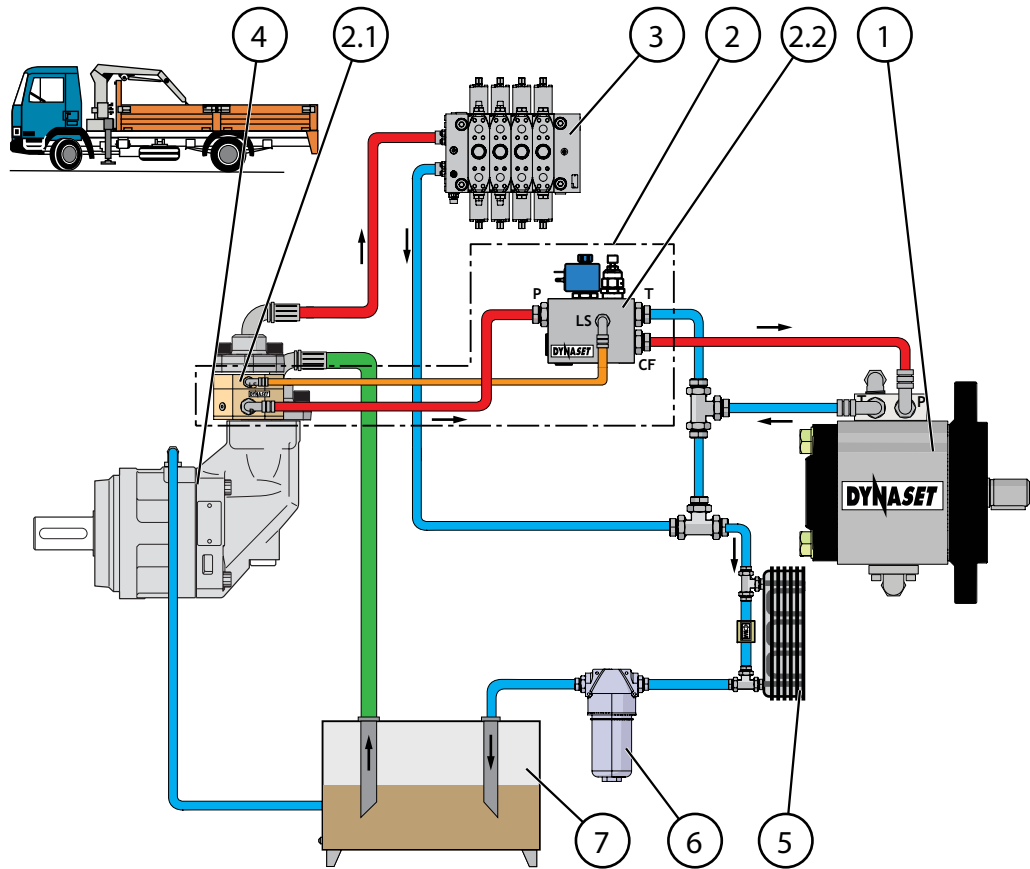

Picture 15: Connection figure for open centre hydraulic system with fixed displacement pump

- |  |   |
|--|---|
| 1. DYNASET hydraulic equipment           | 3. Base machine's fixed displacement pump |
| 2. DYNASET Priority valve PV-SAE         | 4. Open centre directional control valves |
| 2.1. DYNASET PC-SAE pressure compensator | 5. Oil cooler                             |
| 2.2. DYNASET LSV Load Sensing valve      | 6. Oil filter                             |
|  | 7. Oil tank                               |

**HYDRAULIC SYSTEM WITH FIXED DISPLACEMENT PUMP AT FIXED ROTATION SPEED**

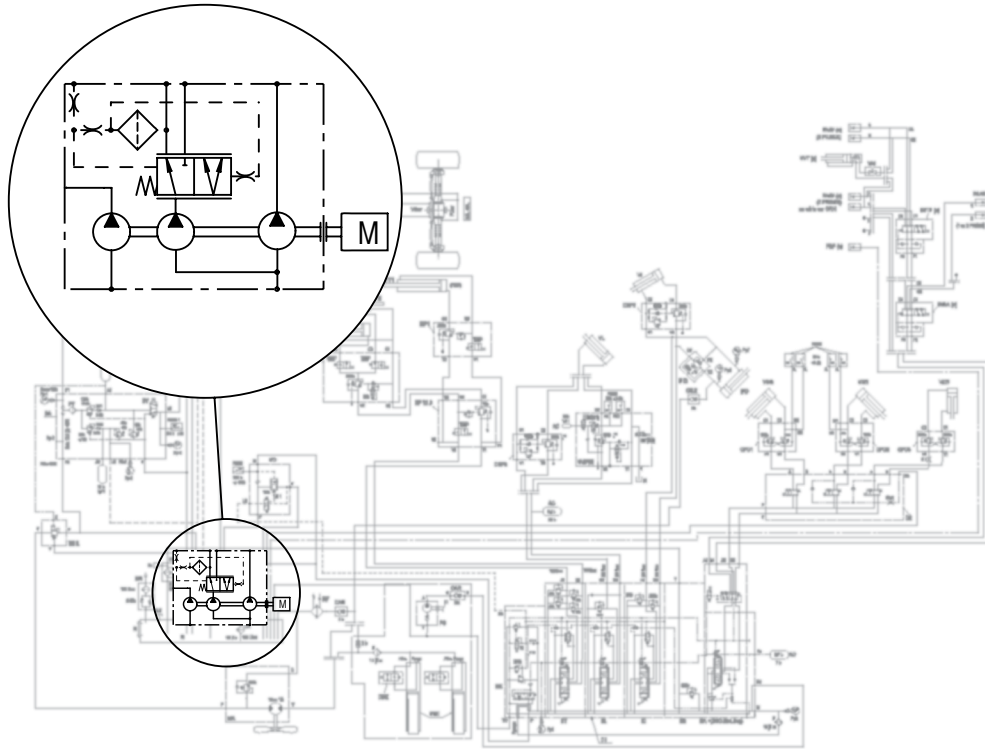

Picture 16: Open centre hydraulic system with fixed displacement pump

In hydraulic system which has the fixed displacement pump, the oil flow from the pump is fixed. Every stroke of the hydraulic motor moves the same amount of oil. The engine of the base machine is set to run at fixed rpm when pump is used.

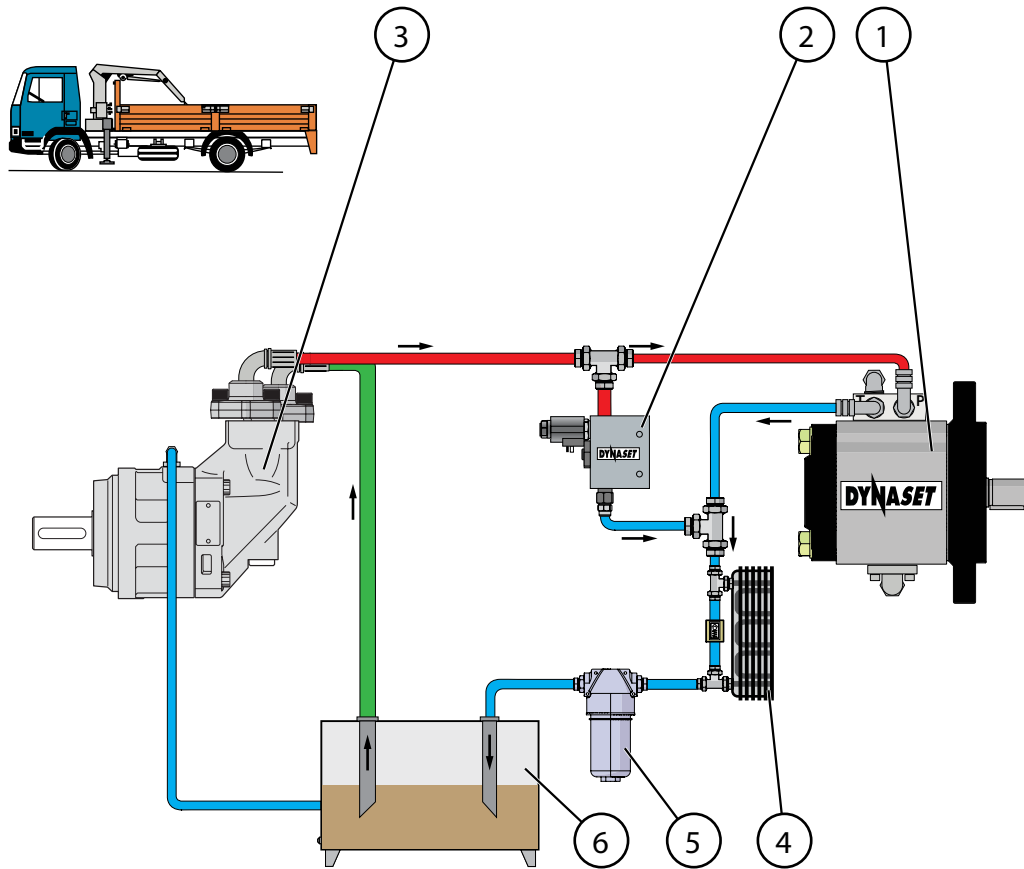

Picture 17: Connection figure for hydraulic system with fixed displacement pump at fixed rotation speed

- |   |               |
|---|---------------|
| 1. DYNASET hydraulic equipment            | 4. Oil cooler |
| 2. DYNASET VKV free flow valve            | 5. Oil filter |
| 3. Base machine's fixed displacement pump | 6. Oil tank   |

#### 4.1.2. DYNASET VALVES

DYNASET valves are designed to enable easy installation of your DYNASET hydraulic product.

##### DYNASET LSV LOAD SENSING VALVE

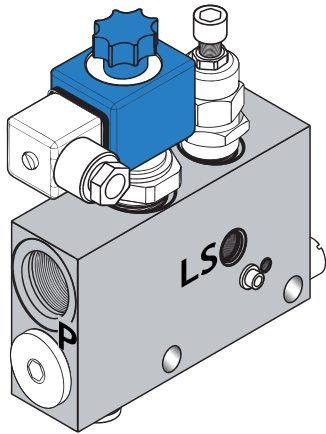

Picture 18: LSV Load sensing valve

DYNASET LSV load sensing valves are made for installations in a closed centre hydraulic systems.

##### DYNASET PV-SAE PRIORITY VALVE

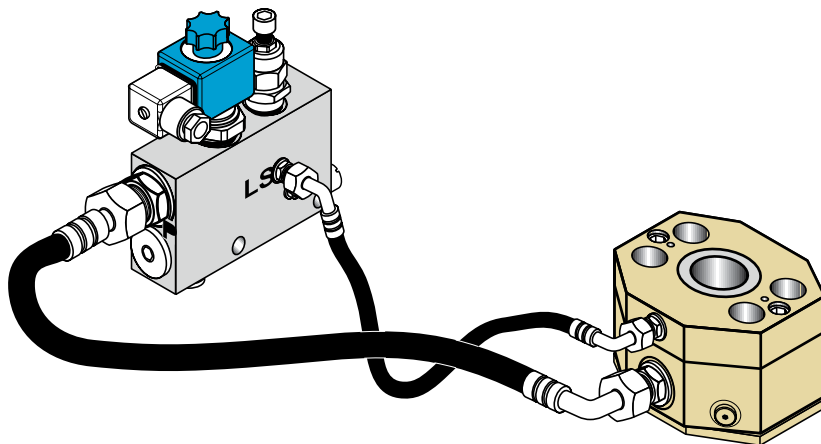

Picture 19: PV-SAE Priority valve

DYNASET PV- SAE priority valve enables the installations of the DYNASET products into any hydraulic system.

## DYNASET VKV FREE FLOW VALVE

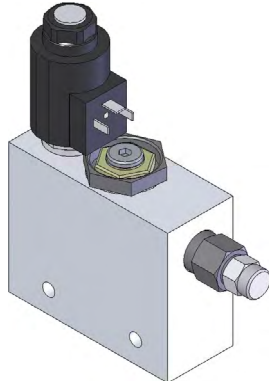

Picture 20: VKV Free flow valve

DYNASET VKV free flow valve enables the installations of the DYNASET products into a hydraulic system with fixed displacement at a fixed rotation speed.

## 4.2. INSTALLING DYNASET HYDRAULIC PRODUCT

### 4.2.1. PLACING DYNASET HYDRAULIC PRODUCT

Place the DYNASET hydraulic product where there is an easy access to the unit. Ensure proper ventilation.

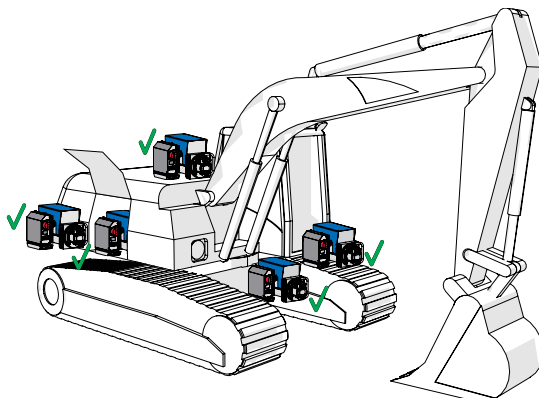

Picture 21: Placing dynaset product

#### ! NOTE!

When positioning the HMG/CMG PRO hydraulic magnet generator, ensure that the air venting is sufficient. READ CHAPTER "4.3.1. Placement" for more information.

#### 4.2.2. INSTALLING DYNASET VALVES

Installation instructions can be found in the DYNASET LSV, DYNASET VKV or DYNASET PV SAE Instructions manual.

#### 4.2.3. CONNECTING HYDRAULIC HOSES

Pressure (P) and return (T) lines of a hydraulic system are connected to the DYNASET units corresponding hydraulic ports.

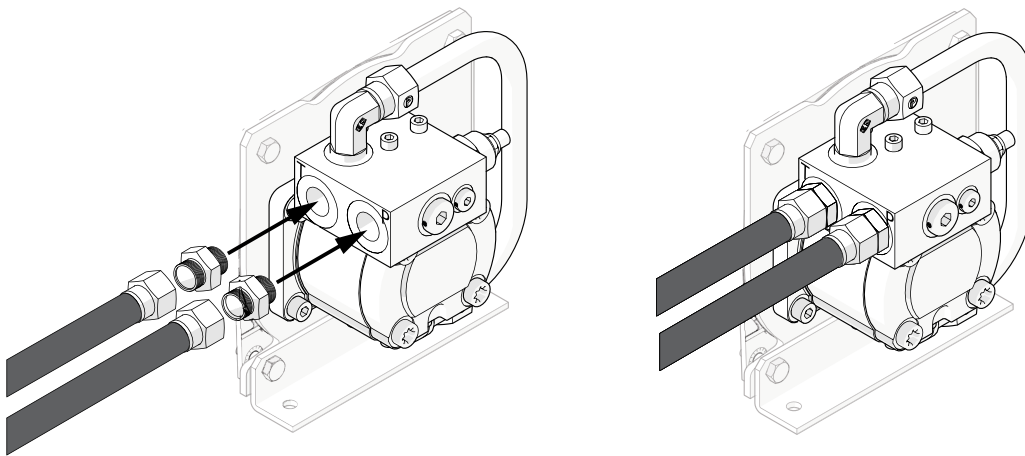

Picture 23: Installing hydraulic hoses

Ensure that the hydraulic flow of the base machine is sufficient to run the unit. At least the minimal flow must be available. READ CHAPTER "10. Technical specifications" for more information.

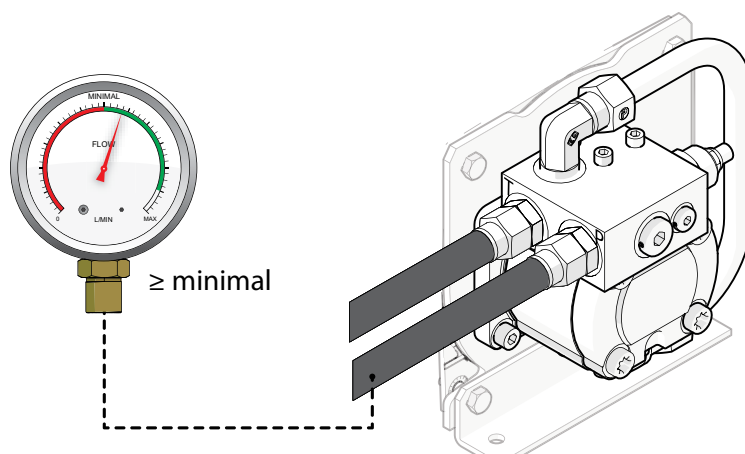

Picture 22: Hydraulic flow at nominal

In case of the hydraulic flow being too high, it must be reduced. The flow can be reduced either by lowering the rotation speed of base machine's hydraulic pump or using flow limiter valve. DYNASET priority valve is recommended.

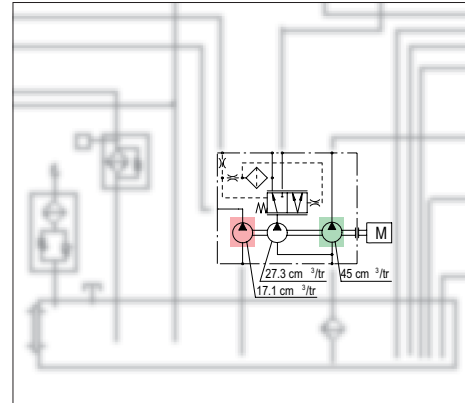
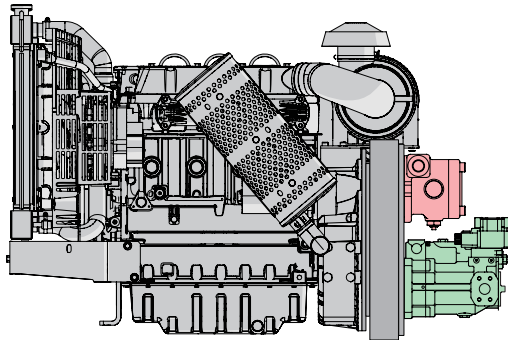

Picture 24: Base machine's pumps

Return line must be connected to a hydraulic oil tank directly in the shortest possible line in order to keep the return hydraulic pressure under 5 bar in the tank line. Generally DYNASET's return line(T) is to be connected directly to the return line of a hydraulic system.

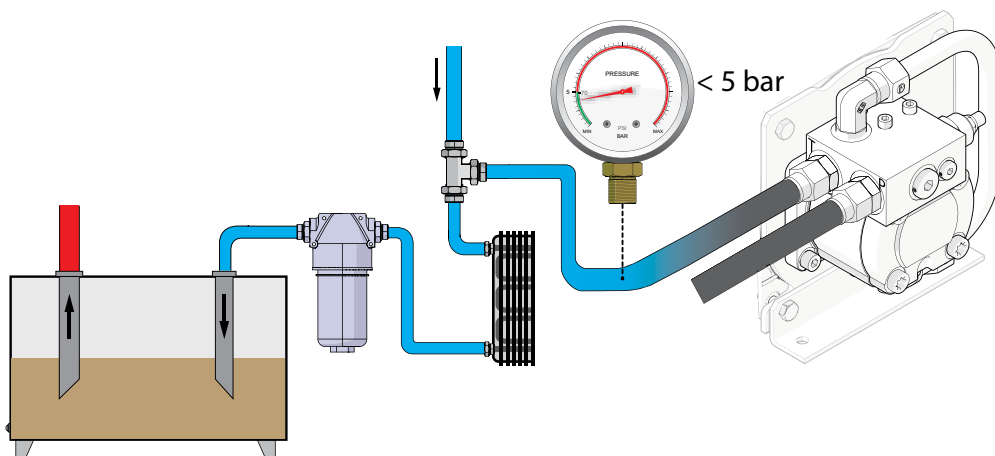

Picture 25: Return line (T) pressure must be under 5 bars.

**⚠ ATTENTION!**

Ensure that the filtering degree and cooling capacity of the hydraulic system are sufficient. READ CHAPTER "10. Technical specifications" for more information.

#### 4.2.4. HYDRAULIC FLUIDS

To use proper hydraulic fluid READ CHAPTER "HMG/CMG PRO suositellut kaapelikoot ja kytkennät" for more information.

### 4.3. INSTALLATION OF THE HMG/CMG PRO

#### 4.3.1. PLACEMENT

DYNASET HMG/CMG PRO hydraulic magnet generator can be installed into the original hydraulic system of any base machine. It can be installed to a place where sufficient venting and easy access to the HMG/CMG PRO is ensured. The position of the generator must be horizontal.

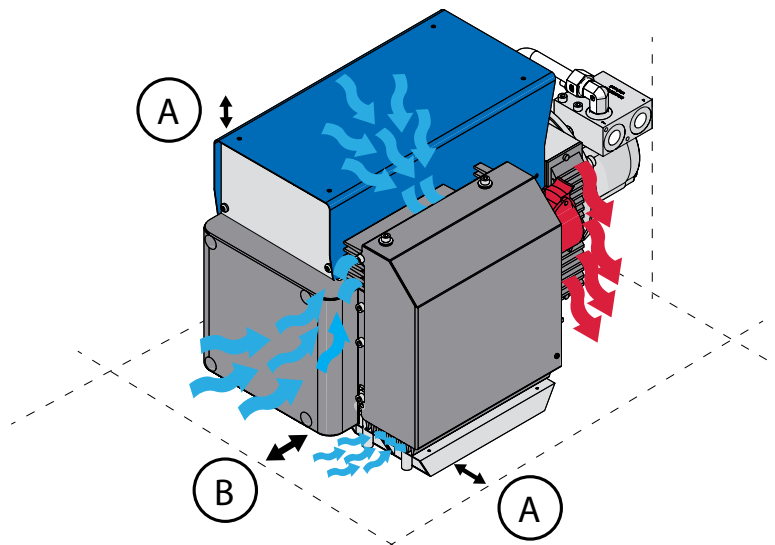

Picture 26: Placement of the HMG/CMG PRO hydraulic magnet generator.

A. Minimum 25 mm

B. Minimum 50 mm

**NOTE!**

Sufficient venting is important. HMG/CMG PROs components heat up during the use. Maintain the generator accordingly and keep the vents open and clean.

An additional oil cooler is required when HMG/CMG PRO unit is installed to a truck with and hydraulic hoist. Ensure that the cooling capacity of your hydraulic system is sufficient. READ CHAPTER "10. Technical specifications" for more information.

### 4.3.2. GROUNDING

**⚠ ATTENTION!**

DYNASET HMG/CMG PRO must be grounded when the rubber cushions or plastic pads are installed to the HMG/CMG PRO's framework. Grounding is also recommended when the generator is installed onto the base machine without rubber cushions or plastic pads.

Do not ground the HMG/CMG PRO hydraulic magnet generator through hydraulic connections. Make the grounding only to the base machines frame. Use external galvanized wire to gain proper grounding as shown in the picture 27. The ground wire size/gauge is to be selected according to the following table.

The ground wire is recommended to be according to the following table.

Generator size S (kW)	Ground wire cross-section area (mm <sup>2</sup> )
S < 10 kW	2.5 mm <sup>2</sup> (13AWG)
10 < S < 20 kW	4 mm <sup>2</sup> (11AWG)
20 < S < 40 kW	6 mm <sup>2</sup> (9AWG)
S ≥ 40 kW	10 mm <sup>2</sup> (7AWG)

Ground the generator from the marked grounding spot in generators frame. Grounding spot of the HMG PRO 10 is shown in the picture 27. The grounding spot varies between different generator models.

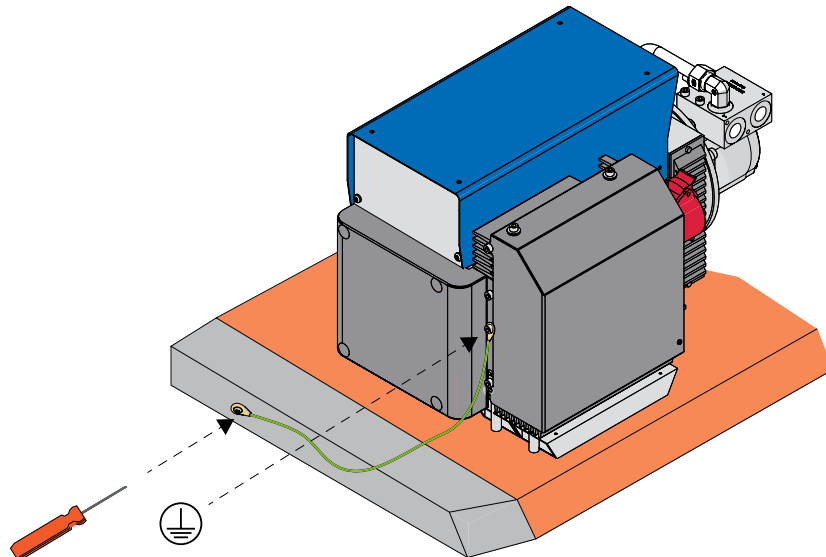

Picture 27: Grounding the HMG/CMG PRO hydraulic magnet generator

### 4.3.3. IP CODE REQUIREMENTS

Dynaset products with the IP class IP23 must be installed into a place where water can't enter the generator from below or from the sides according to the IP23 classification

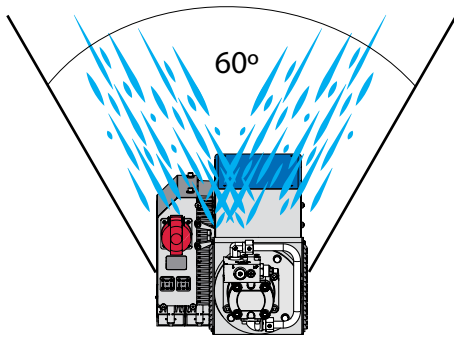

Picture 28: IP classification requirements

### 4.4. OUTPUT VOLTAGE INSPECTION AT START-UP

HMG/CMG PROs are tested and adjusted at the factory but it is recommended to check the DC voltage before taking the HMG/CMG PRO into operation.

1. Ensure that the generator is properly connected to the hydraulic system of your base machine and there are no oil leakages in the system.
2. Start the engine of your base machine. Adjust the engine speed to demanded level if necessary.
3. Start the generator by opening the hydraulic flow to the generator.
4. Turn on the magnet:
  - A. HMG PRO: Turn the magnet ON with ON/OFF switch.
  - B. CMG PRO: magnetization starts immediately when the the hydraulic flow is opened to the generator.

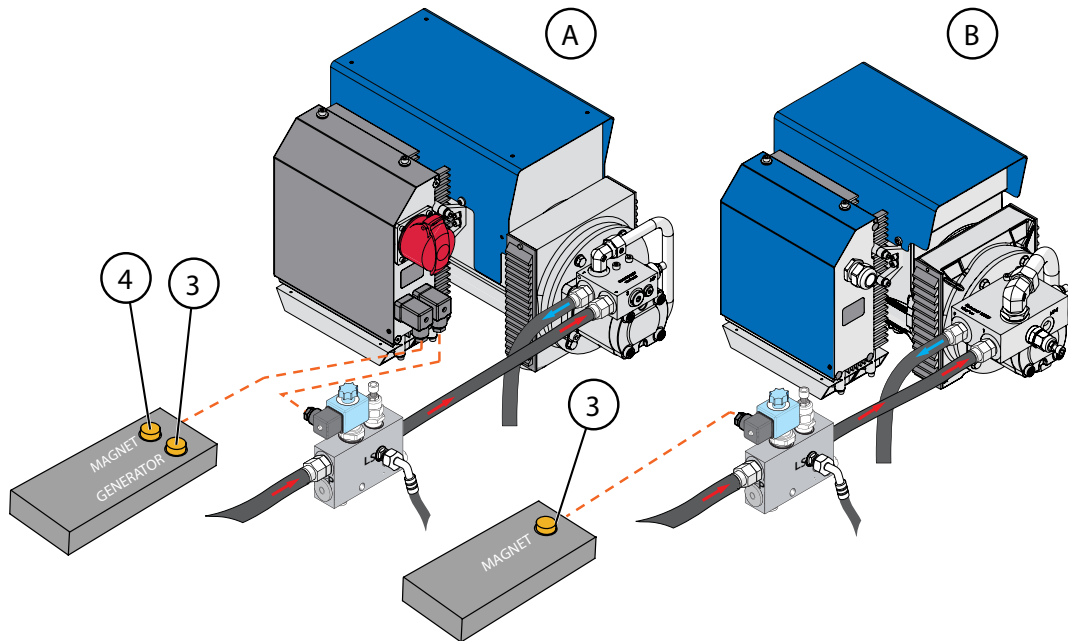

Picture 29: Starting HMG/CMG PRO

5. Check the voltage from generator's display. The voltage should be  $220\text{VDC} \pm 5\%$ .



Picture 30: Adjusting voltage

6. Adjust the voltage if necessary. READ CHAPTER "Asetukset MASTER-kortille" for more information.

**NOTE!**

DYNASET HMG/CMG PRO hydraulic magnet generators are tested and adjusted at the factory! Do not adjust the voltage without real need.

#### 4.5. HGM/CMG PRO CONTROL CARD SETTINGS

Control mode settings for control cards are made with the following instructions with DIP-switches SW1 and SW2, both located on a control card as shown in the picture 31.

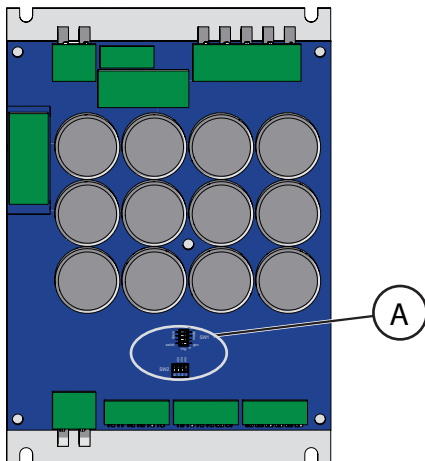

Picture 31: Location of the DIP switches on the control card

A. DIP switches SW1 and SW2

##### 4.5.1. SETTINGS FOR SINGLE/MASTER CONTROL CARD OPERATION

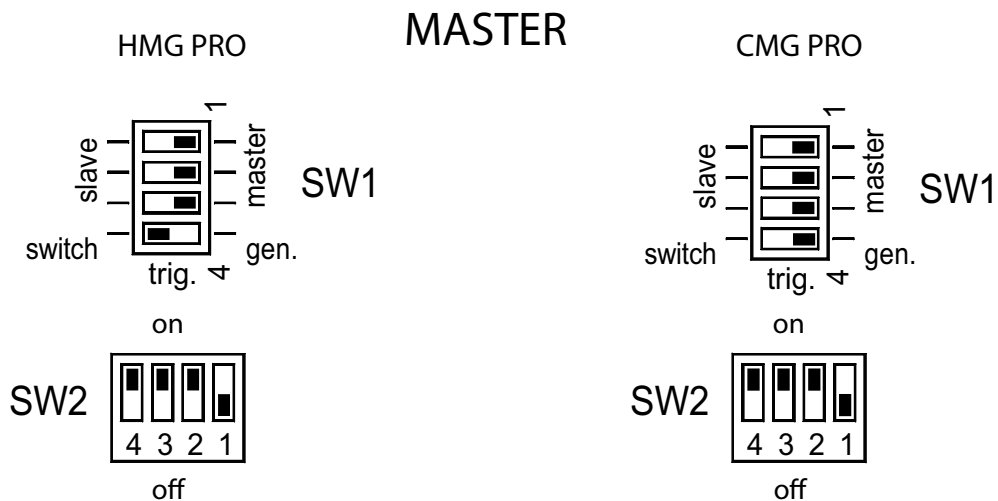

Picture 32: Single/MASTER card DIP switches

DIP switch SW1:

- Switches 1 - 3 on MASTER position.
- Switch 4, select the operation mode.

DIP switch SW2:

- Switch 1 at ON position, enables hard demagnetization.
- Switch 2-4 on OFF position

**Switch 1** enables normal and hard demagnetization (giving 30% more efficient, but is slower).

**Switch 2** internal function.

**Switch 3** enables the power reduction mode with HMG PRO. "4.5. HGM/CMG PRO control card settings".

**Switch 4** selects the operation mode:

- SWITCH, when push button is used for external control in HMG PRO operation.
- GEN, when hydraulically controlled voltage level is used in CMG PRO operation.

#### 4.5.2. SETTINGS FOR MULTIPLE CONTROL CARD OPERATION

Depending on the size of the HMG/CMG PRO generator, control units can be equipped with more than one control card. The following instructions are for the models where two or more control cards are used.

HMG PRO 12 - 20kW has two (2) cards. HMG PRO 30kW has three (3) and HMG PRO 40kW has four (4) cards.

#### NOTE!

The MASTER card is installed on the right side and SLAVE card to the left side of the control unit as shown in the picture 33.

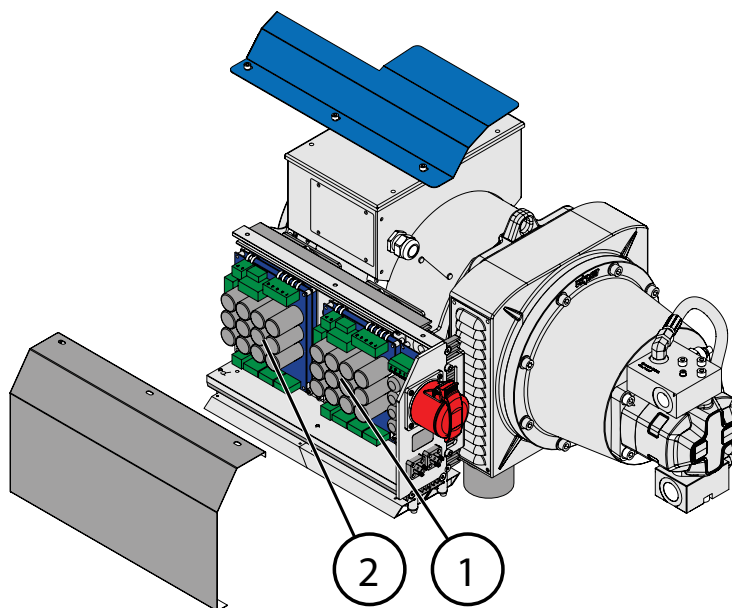

Picture 33: MASTER and SLAVE card order

1. MASTER card

2. SLAVE card

### FIRST (MASTER) CARD SWITCH SETTINGS:

The settings are the same for the MASTER control card as they are in single card use. Use the settings on the chapter 4.5.1 for the MASTER card settings.

**! ATTENTION!**

Dip switches on the SW2 should be set to the same position in all the control cards.

### SECOND (SLAVE) CARD AND ADDITIONAL (SLAVE) CARDS SWITCH SETTINGS:

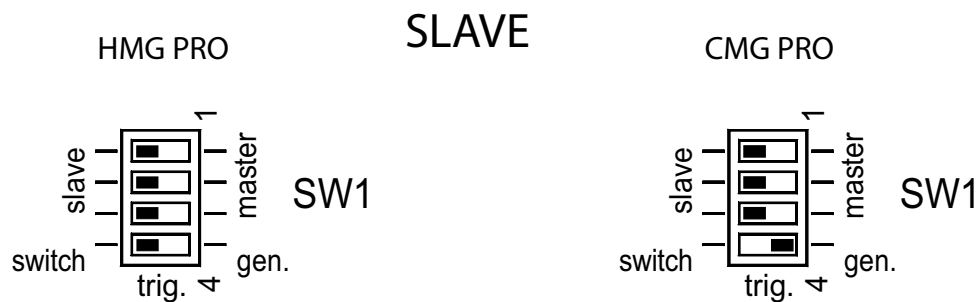

Picture 34: Multiple card DIP switches

DIP switch SW1:

- Switches 1 - 3 to the SLAVE position.
- Switch 4 selects the operation mode:
  - SWITCH, when the push button is used for the external control of the HMG PRO operation.
  - GEN, when the hydraulic controlled voltage level is used to control a CMG PRO operation or HMG PRO in hydraulic mode.

#### 4.6. WIRE SIZES AND WIRING FOR THE HMG/CMG CABLES

Following table contains the recommended sizes for the output cables and sockets when using the HMG/CMG PRO.

MODEL	CABLE SIZE		SOCKET SIZE
HMG/CMG PRO 3 kW	5 x 2,5mm <sup>2</sup> (3 x 6mm <sup>2</sup> )	13AWG5 (9AWG3)	5 x 16 A
HMG/CMG PRO 6 kW	5 x 2,5mm <sup>2</sup> (3 x 6mm <sup>2</sup> )	13AWG5 (9AWG3)	5 x 16 A
HMG/CMG PRO 10 kW	5 x 6mm <sup>2</sup> (3 x 10mm <sup>2</sup> )	9AWG5 (7AWG3)	5 x 16 A
HMG/CMG PRO 12 kW	5 x 6mm <sup>2</sup> (3 x 10mm <sup>2</sup> )	9AWG5 (7AWG3)	5 x 32A
HMG/CMG PRO 15 kW	5 x 6mm <sup>2</sup> (3 x 10mm <sup>2</sup> )	9AWG5 (7AWG3)	5 x 32A
HMG/CMG PRO 20 kW	5 x 10mm <sup>2</sup> (3 x 16mm <sup>2</sup> )	7AWG5 (5AWG3)	5 x 63A
HMG/CMG PRO 30 kW	5 x 10mm <sup>2</sup> (3 x 16mm <sup>2</sup> )	7AWG5 (5AWG3)	5 x 63A
HMG/CMG PRO 40 kW	5 x 10mm <sup>2</sup> (3 x 16mm <sup>2</sup> )	7AWG5 (5AWG3)	5 x 63A

If you are using an another kind of cable, ensure the proper cable size. Cable wiring options to the magnet are described in the picture 35.

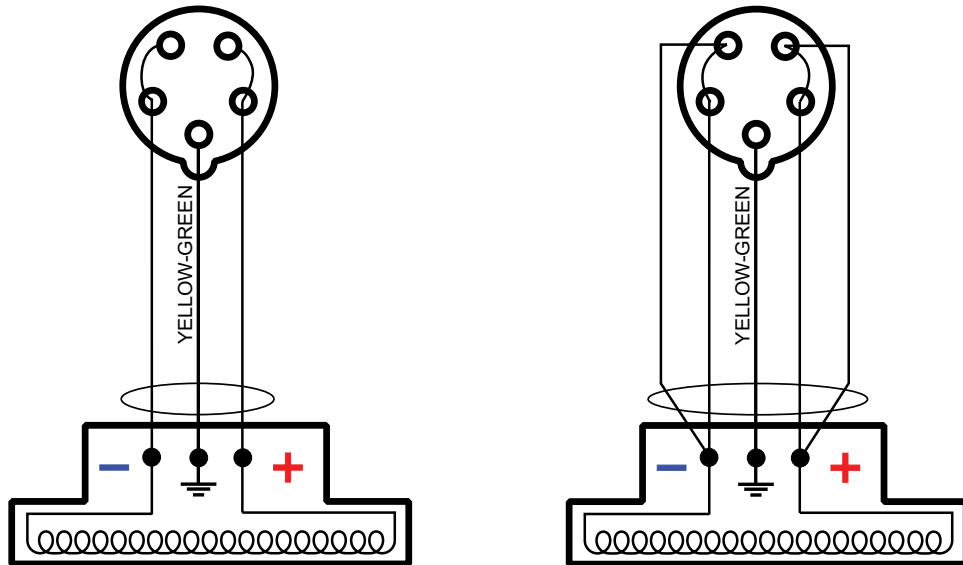

Picture 35: Wiring for the cable from the generator to the magnet

#### 4.7. OPTIONAL ELECTRIC INSTALLATIONS

Optional DYNASET magnet cable kit can be purchased for connecting DYNASET HMG PRO to the magnet. Also optional HMG PRO control wiring kit is available to enable the external control connections.

##### HMG PRO MAGNET CABLE KIT

Magnet's wiring kits is suitable for all of the HMG PRO units the kit includes

1. Socket with a protective cover, to be fitted to a boom
2. 20 m cable from the booms socket to the generator's socket, with a plug.

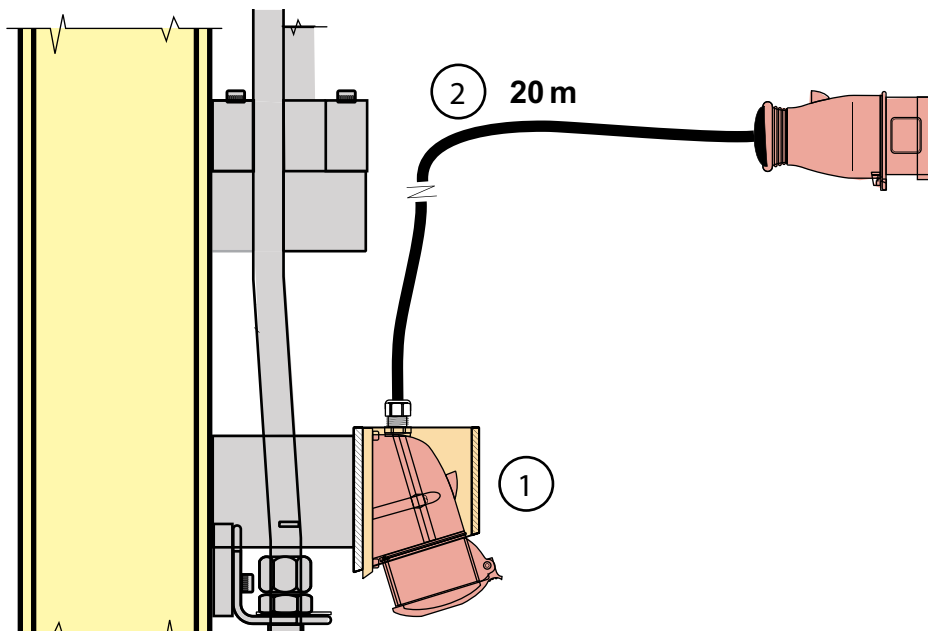

Picture 36: Protected booms socket and 20m cable to the magnet generator

##### HMG PRO CONTROL WIRING KIT

HMG PRO control wiring kit is available for all externally controlled HMG PRO units. The kit includes:

- control switch for the magnet,
- generator's starting switch,
- plugs for generator and solenoid valve,
- magnetization signal light and
- cables (5m)

Switches can be placed on a dashboard or to any other suitable place.

Wiring kit contains signal light to show the magnetizing phase.

- When the magnet is magnetized the indicator light will turn on
- When the demagnetization is on the indicator light will turn off

#### 4.8. MAGNET COMPATIBILITY TABLE

The following table shows an appropriate lifting magnet for different HMG/CMG PRO models. Suitable DYNASET MAG lifting magnets are also listed. Coil resistance values are measured at +15°C temperature.

GENERATOR MODEL	MAGNET RESISTANCE		RECOMMENDED LIFT MAGNET TYPE	
	Min	Max	General	DYNASET
HMG/CMG PRO 3 kW	15	100	2,5 kW	MAG 700
HMG/CMG PRO 6 kW	8,8	100	5,1 kW	MAG 900
HMG/CMG PRO 10 kW	5,4	100	8,4 kW	MAG 1200
HMG/CMG PRO 12 kW	4,5	50	10,1 kW	MAG 1400
HMG/CMG PRO 15 kW	3,6	50	12,6 kW	MAG 1500
HMG/CMG PRO 20 kW	2,6	50	16,8 kW	MAG 1600
HMG/CMG PRO 30 kW	1,8	30	25,2 kW	MAG 1800
HMG/CMG PRO 40 kW	1,3	20	33,6 kW	MAG 2200



Picture 37: DYNASET MAG

#### 4.8.1. MEASURING HMG/CMG PRO RESISTANCE

HMG/CMG PRO resistance can be measured from the socket as shown in the picture 39. Measure the resistance from the socket in both ways.

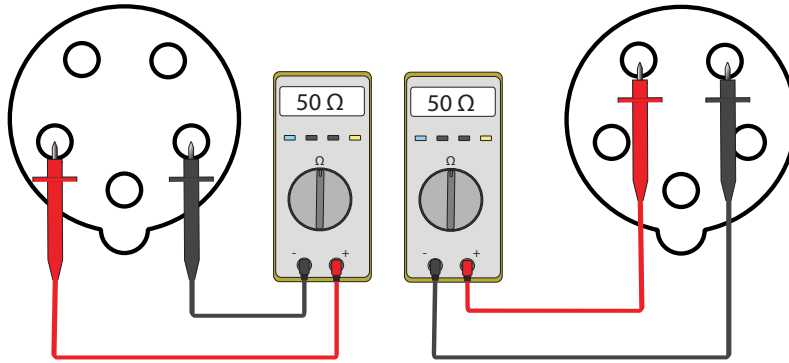

Picture 39: Measuring HMG/CMG PRO's resistance

The reading should be same in both ways. If not the cable is damaged or wired incorrectly. READ CHAPTER "4.6. Wire sizes and wiring for the HMG/CMG cables" for more information

#### 4.8.2. MEASURING MAGNET'S RESISTANCE

Magnet's resistance can usually be measured between the magnets + and - poles as shown in the picture 40. Check the correct way to measure resistance from the magnet's manual or take contact to the magnet's manufacturer.

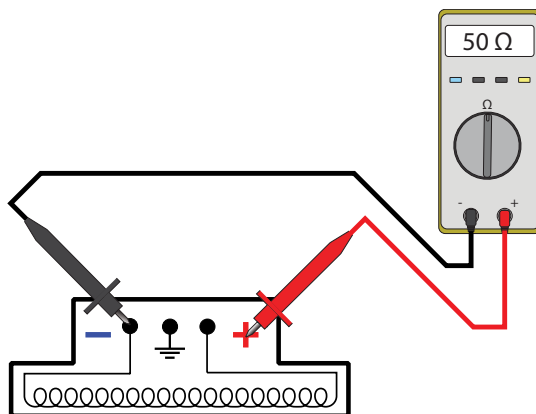

Picture 40: Measuring resistance from the magnet

## 5. OPERATION

### ATTENTION!

Check the HMG/CMG PRO hydraulic magnet generator and its hoses condition before use to ensure there are no leaks or damages.

After having ensured the proper mechanical and hydraulic installation of the HMG/CMG PRO unit, plug the magnet into the generator's socket with a suitable cable (Dynaset cable kit recommended).

### 5.1. OPERATING THE HMG/CMG PRO

#### WITH HYDRAULIC CONTROL

1. Start base machines engine and move the magnet to the working area.
2. Open the hydraulic flow and to the the HMG/CMG PRO begin the magnetization.

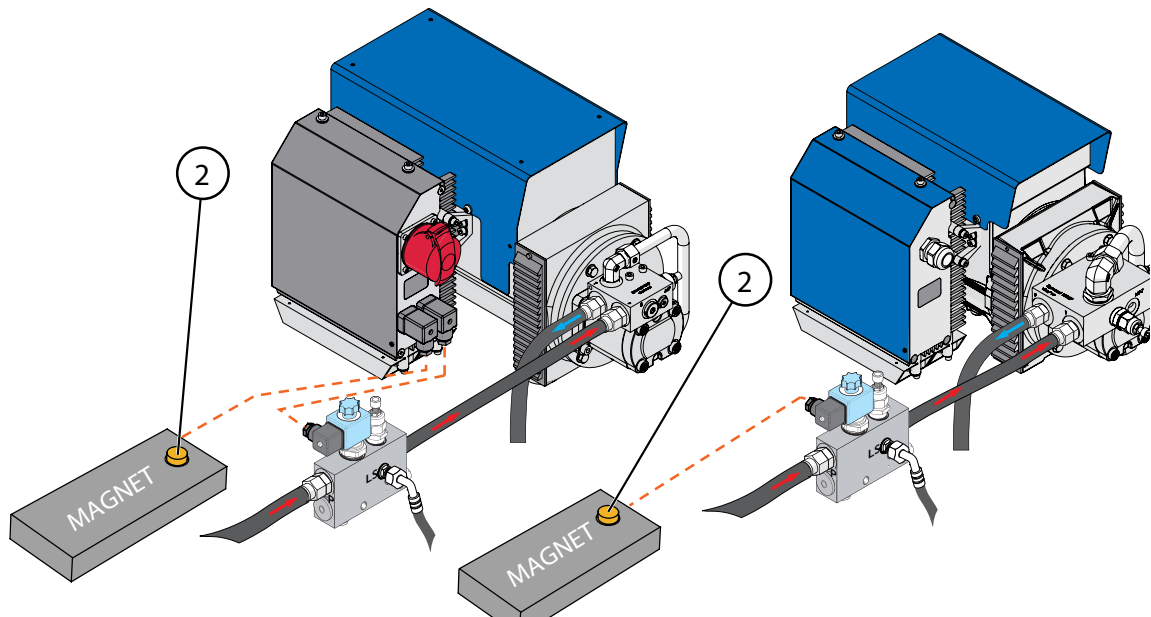

Kuva 41: Hydraulic operation method

### NOTE!

The switch has to be pressed on all the time during the collecting and moving metals to enable magnetization.

3. Release the control switch to demagnetize and drop the collected metals.

## WITH EXTERNAL CONTROL

1. Start machine's engine and move the magnet to the working area.
2. Open the solenoid valve of the HMG PRO with the assigned switch.

HMG PRO generator is ready for the use when the hydraulic flow and the pressure achieve the minimum level. Generator is running constantly in this installation when the pressure line is open.

3. Activate the magnet by pressing the assigned switch once.
4. To drop the collected material, press the same switch again to demagnetize the magnet.

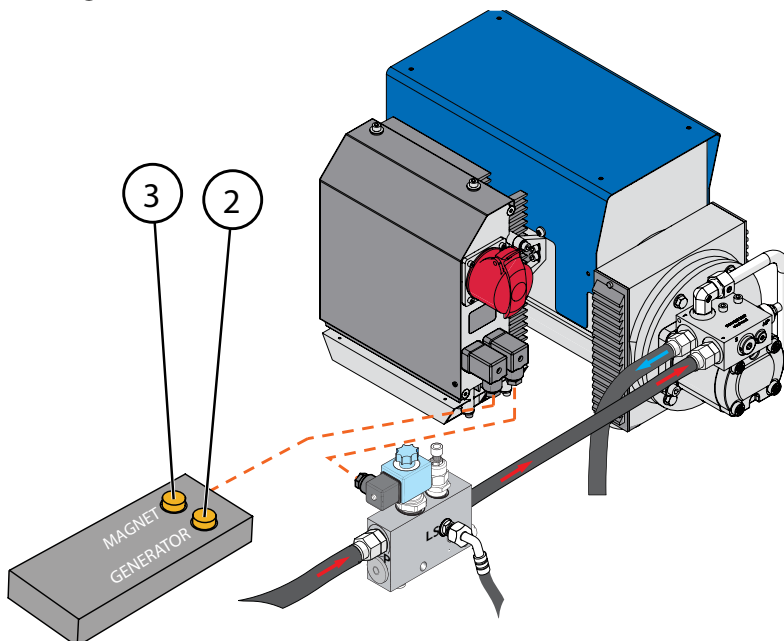

Picture 42: Operating the magnetization by controlling magnet generator's magnetizing voltage

## 5.2. POWER REDUCTION MODE

In power reduction mode the collected metals can be sorted after being lifted. Sorting means that the lowest collected metals can be separated from the rest of the stack. Power reduction mode is only available with HMG PRO.

For this mode the reduction mode must be enabled on the HMG PROs control card. READ CHAPTER "4.5.1. Settings for single/MASTER control card operation" for more information

When the reduction mode is enabled the collected metals can be sorted in the following way.

1. Lift the collected metals with the magnet
2. Push and hold the magnetizing/demagnetizing button. When the first metal part drops release the button to continue magnetization.

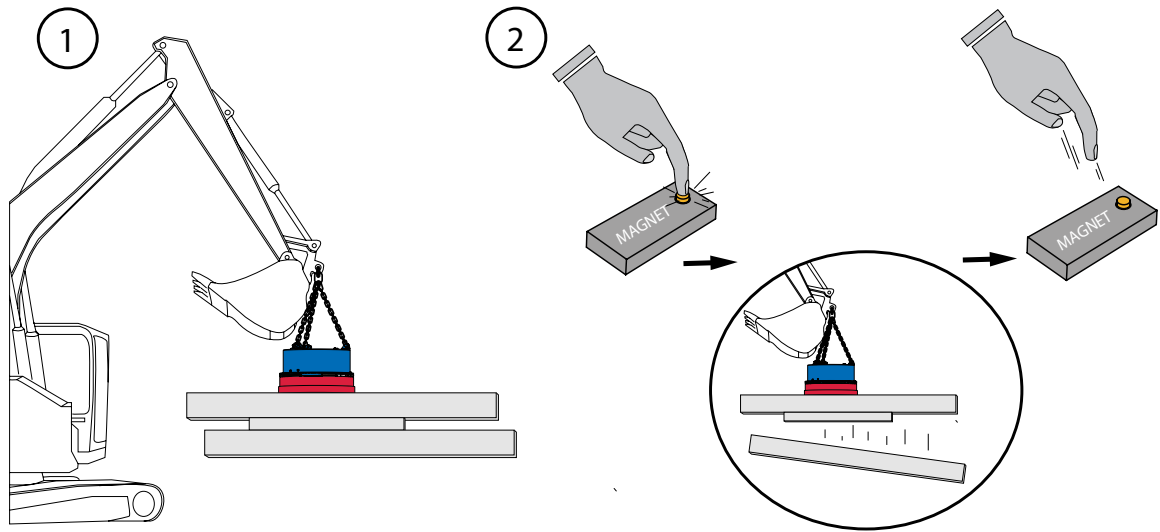

Picture 43: Operating in the reduction mode

If button is released too soon (less than 0,5 sec.) the reduction mode won't activate and the magnet will fully demagnetize.

### 5.3. DISPLAY OF THE HMG/CMG PRO

The display shows the main phases of the magnetization, magnetizing voltage and error messages. READ CHAPTER "Lajittelutoiminto" for more information about the error messages.

#### MAIN STEPS OF MAGNETIZATION

Magnetization is divided into three main steps.

1. Magnetization, when the magnet is magnetized with the HMG/CMG PRO generator.
2. Magnet field dampen, when the HMG/CMG PRO generator is cut off and the magnet starts to demagnetize.
3. Demagnetization, when the magnet is fully demagnetized.

When the magnetizing is started the magnetizing voltage is shown on the display between the steps 1 & 2.



Picture 44: Generator's main steps and voltage sequence's on the display

#### 5.4. HOW TO STOP THE HMG/CMG PRO

Stop the HMG PRO by switching off the hydraulic flow to the generator.

CMG PRO shuts off when the button enabling the hydraulic flow to the generator is released.

#### 5.5. OVERHEAT AND OVERLOAD SITUATION

HMG/CMG PRO's alternator and control card are equipped with a temperature measuring circuit. In overheat situations the error message O.HEA shown on the display.

In control unit's overheating situations, control electronics prevent the HMG/CMG PRO to magnetize the magnet until the temperature in control unit drops.

When alternator's temperature switch trips, the magnetization should be switched off in order to cool HMG/CMG PRO generator as fast as possible.

After few minutes, when the HMG/CMG PRO generator has cooled down, the unit automatically switches the overheat alarm off and is operatable again.

---

 **NOTE!**

**Check and obey the magnet manufactures load duty value (ED). Exceeding of the ED-value causes HMG/CMG PRO to overheat ! in need of more information about the ED-value take contact to magnet's manufacturer.**

---



Picture 45: O.HEA on the Display

#### 5.6. AMBIENT TEMPERATURE

To avoid the power loss, it is not recommended to use the HMG/CMG PRO when the ambient temperature exceeds +40 °C. When the ambient temperature exceeds +40 °C power takeoff should be limited in accordance with the attached diagram in picture 46, e.g. for instance, at the ambient temperature of +50 °C the power takeoff should not be more that 80 % of the maximum.

If the ambient temperature achieves +40 °C, the HMG/CMG PRO's full output power can be maintained by adding an additional air ventilation.

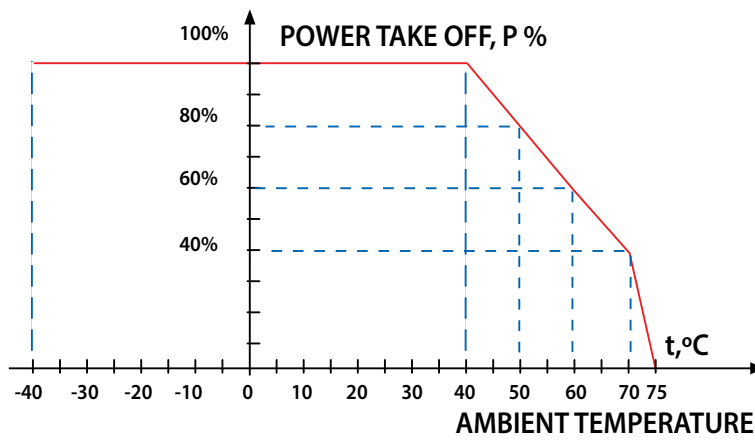

Picture 46: Power take off in higher temperatures



HYDRAULIC MAGNET GENERATORS  
OPERATION

## 6. MAINTENANCE

DYNASET HMG/CMG PRO hydraulic magnet generators are low-maintenance units. Only normally wearing parts such as sealings in hydraulics, brush collector and bearings are needed to be replaced when necessary.

### ATTENTION!

Before beginning any maintenance or repair, ensure that the system is stopped and depressurized. Make sure that the system can not start accidentally.

### 6.1. MAINTENANCE INTERVALS

All maintenance must be complied as they are scheduled in this manual. The following table provides maintenance schedule for the HMG/CMG PRO.

CHECK POINTS	NEW DEVICE AFTER INSTALLATION	AFTER DAILY USE
Perform the needed actions after each HMG/CMG PRO hydraulic magnet generator installation according to the chapter 4. Installation.	x	
Check if the HMG/CMG PRO hydraulic magnet generator need cleaning and clean it according to the chapter 6.3.		x

### 6.2. HYDRAULIC FLUIDS

Wide range of standard hydraulic fluids can be used with the DYNASET hydraulic equipment. Depending on the operating temperature, following mineral hydraulic oils are recommended:

MINERAL HYDRAULIC OIL	OPERATION TEMPERATURE UP TO
ISO VG 32S	60 °C
ISO VG 46S	70 °C
ISO VG 68S	80 °C

Synthetic and bio oils can also be used if their viscosity characteristics and lubricating efficiency are corresponding to the mineral oils.

Automatic transmission fluids and even engine oils can be used, provided that they are allowed to be used in the hydraulic system of your base machine.

Hydraulic fluid change interval is according to the base machine's maintenance instructions. To use special hydraulic fluid with DYNASET equipment, please contact nearest DYNASET representative for an advice.

### 6.3. CLEANING THE HMG/CMG PRO

**! ATTENTION!**

Maintain the generator accordingly and keep the vents open and clean. Check your equipment after every work shift.

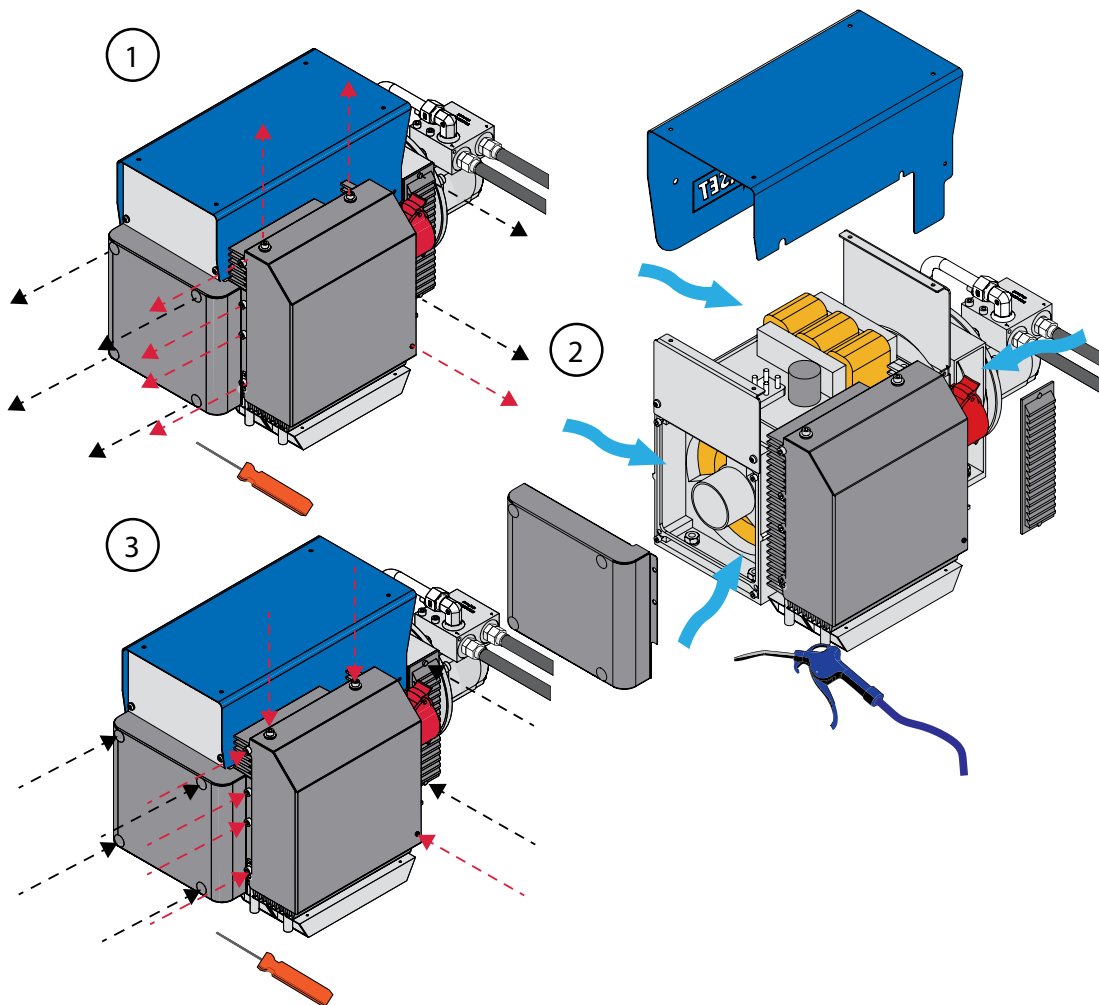

Picture 47: Cleaning the HMG/CMG PRO

Depending on the operational environment, clean the HMG/CMG PRO as frequently as necessary to maintain it in perfect working condition.

1. Remove the generator's cover, side screens and the air diffuser.
2. Clean fan, rotor, stator compartments and alternator's electric components by using compressed air. Ensure that the electric enclosures drain holes are dirt free.
3. After cleaning the generator, place the screens/covers back on and secure them with appropriate screws.

---

 **NOTE!**

Use compressed air to clean your equipment.

---

Remove all unnecessary grease and oil deposits from the HMG/CMG PRO. Accumulated grease and oil can cause overheating and a potential fire hazard.

---

 **ATTENTION!**

Do not leave anything inside the generator case or control box which does not belong to the assembly.

---

Check the lids and the covers as well as the screw joints on regular basis, at least once in a week, and tighten them if they are loose. If HMG/CMG PRO is exposed to a noticeable vibration, checking should be done more frequently.

---

 **NOTE!**

Ensure clean venting of the HMG/CMG PRO. Components wearing increases in dusty conditions.

---

#### 6.4. REPLACING CONTROL CARD

Replace the control card with the following instructions.

---

 **NOTE!**

When replacing control card to multiple card control unit, all replaced control cards must be the same alphabetical letter (e.g. EM-xxxf, e ...) type version to ensure HMG/CMG PRO stable and correct function.

---

1. Open the control box cover by unscrewing the screws.
2. Disconnect the wires and plugs from the faulty card. If needed mark the wires and the plugs for the installation to secure them back on to their correct places for the new card.
3. Unscrew all the control card's screws (5) and remove the faulty card.

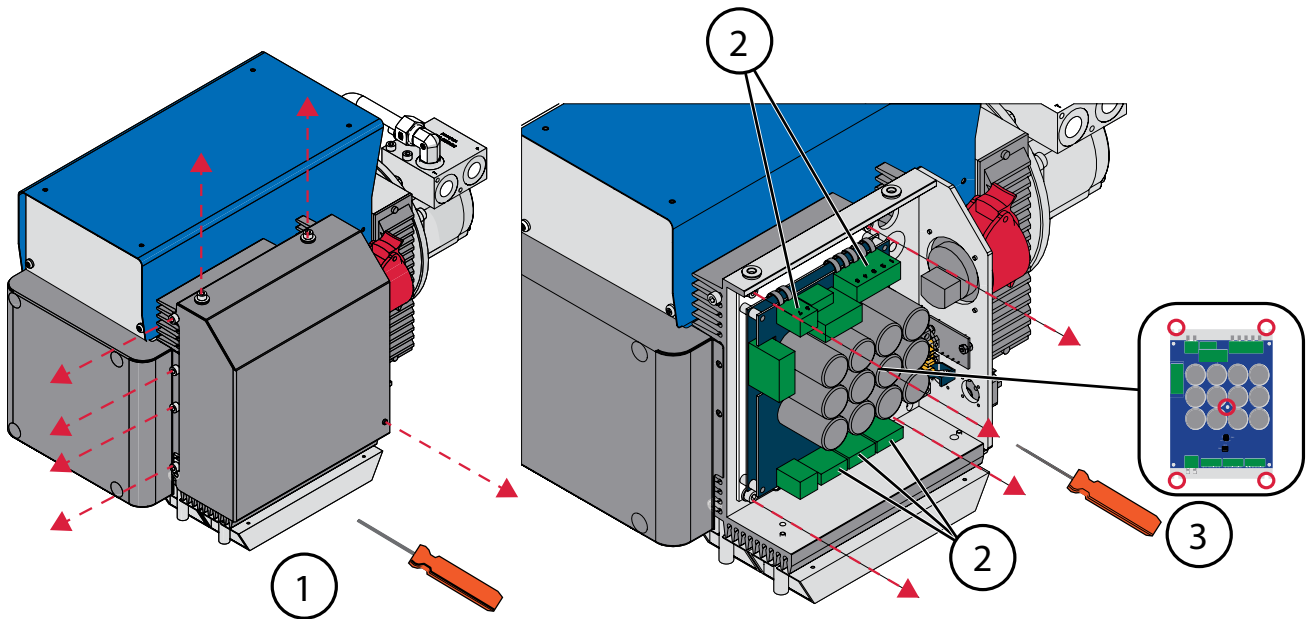

Picture 48: Removing control card

4. Apply the thermal paste provided with the card or quality thermal paste to the bottom of the new card

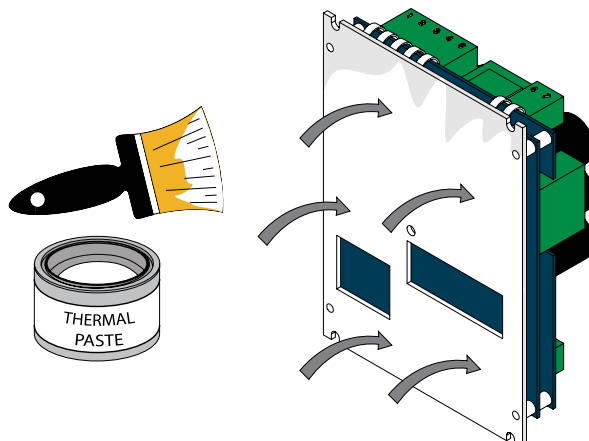

Picture 49: Apply the thermal paste

5. Install the new card to its place. Plug on all wires, plugs and screws(5). Tighten the screws into the 4Nm moment.

**NOTE!**

Remember to check that the dip switches on the new control card are in correct position. READ CHAPTER "4.5. HGM/CMG PRO control card settings" for more information.

6. Screw the control box cover back on

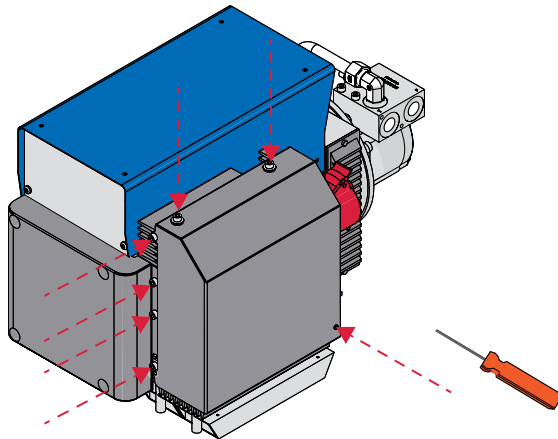

Picture 50: Installing the control box cover

After installing the new card HGM/CMG PRO is operational.

## 6.5. OUTPUT VOLTAGE ADJUSTING

### WHEN HGM/CMG PRO IS INSTALLED INTO THE HYDRAULIC SYSTEM WITH A DYNASET INSTALLATION VALVE

**ATTENTION!**

The HGM/CMG PROs are tested and adjusted at the factory. Do not adjust them without real need. Adjust first the base machine's hydraulic flow to demanded level.

**ATTENTION!**

When measuring the output frequency, act in compliance with the laws, regulations and recommendations issued by the local electricity, work safety authorities and universal multimeter manufacturer.

**⚠ ATTENTION!**

Do not adjust the generator when a magnet is connected to it.

**📌 NOTE!**

When doing adjustment, the hydraulic fluid should be at normal operation temperature! READ CHAPTER "6.2. Hydraulic fluids" for more information.

Turn the generator on and ensure that the hydraulic flow is at the minimal level. When the hydraulic flow is at the proper level, set the voltage by adjusting the RPM-cartridge with following instructions.

1. Loose the locknut A.
2. Adjust the adjusting screw B according of the voltage shown on the generator's display. Due to the response time make only a small adjustment at a time and wait for the generator to level its speed before turning the screw B more. **Do not make more than quarter revolution turns at the time!**
3. When the voltage has reached the required 220 VDC - tighten the locknut A to 10 Nm.

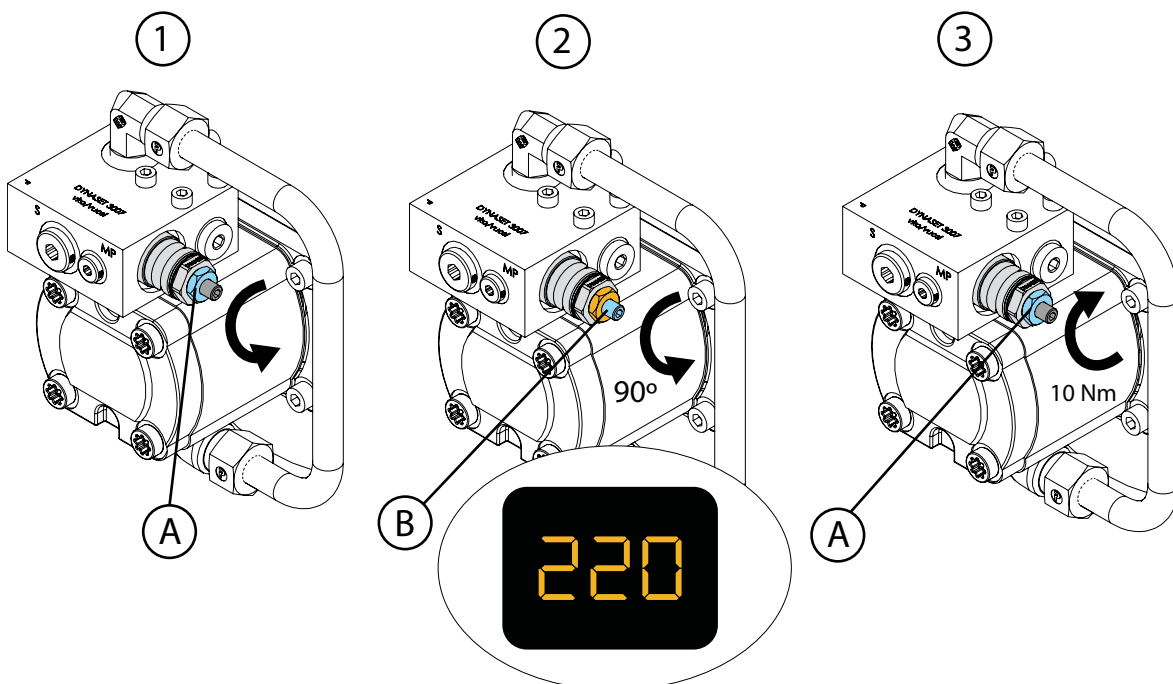

During the adjustment U.CUR will blink on the display. This is normal. Do not attach magnet on to the generator while measuring the voltage.

If voltage measurement option is not available, adjustments can be made by measuring the output frequency (50Hz).

**WHEN HMG/CMG PRO IS INSTALLED TO THE HYDRAULIC SYSTEM  
WITHOUT DYNASET INSTALLATION VALVE****⚠ ATTENTION!**

Adjust only with the following instructions when the HMG/CMG PRO is installed to the hydraulic system without a DYNASET installation valve. Otherwise you may damage your HMG/CMG PRO doing the procedure.

Primarily adjust the base machine's hydraulic flow to the required, nominal level before making any adjustment to the RPM-cartridge. If the voltage is still out of the range, adjust the RPM-cartridge with the following instructions.

1. Adjust the hydraulic flow until the output voltage will achieve the value of 220 VDC. Follow the readings of generator's display.

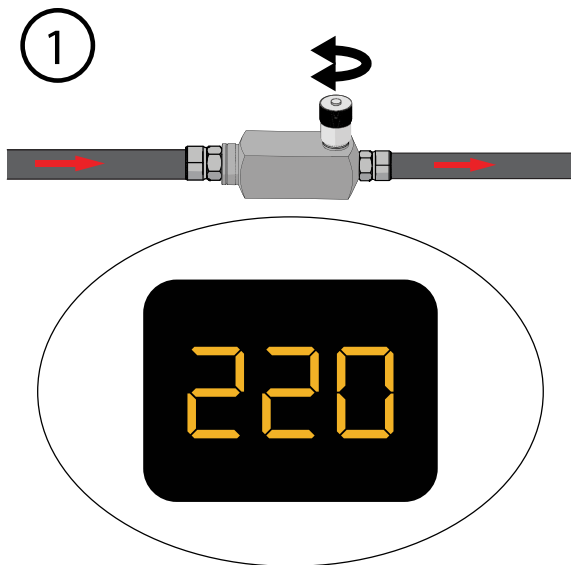

If the adjusting does not effect on the output voltage, there is a feed problem in the base machines hydraulic system that has be fixed before continuing the adjustments.

If the output voltage does change when the adjustments are made to the hydraulic flow, continue with the following instructions.

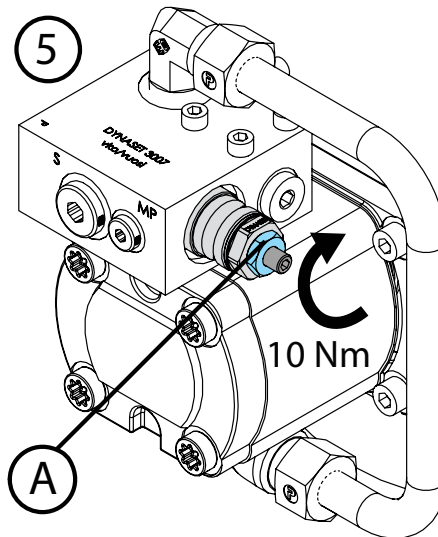
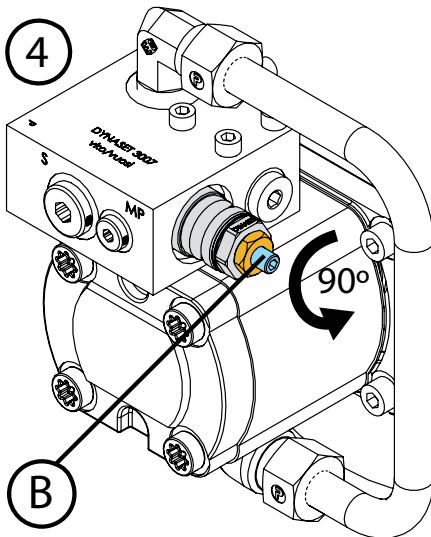
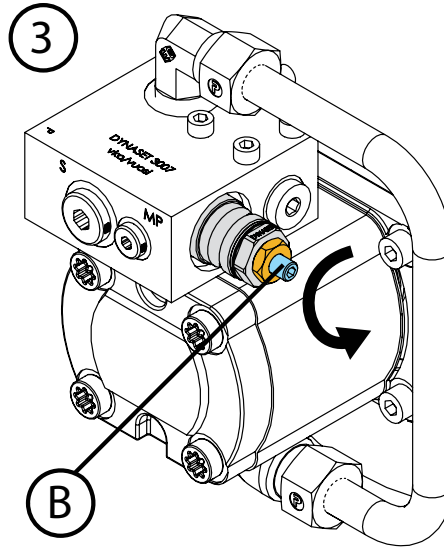
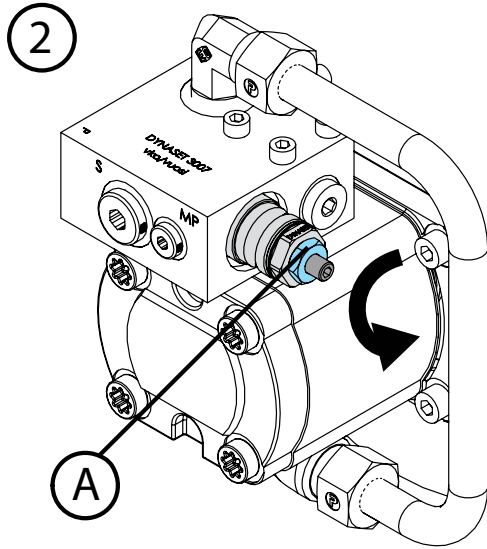

2. Loose the locknut A.
3. Turn the adjusting screw B counter-clockwise until it starts to control the flow.
4. Then turn the screw B counter-clockwise for a another quarter of revolution.
5. Lock the setting with locknut A tightening it to 10 Nm.



### 6.6. TROUBLESHOOTING

Performing these maintenance tasks requires a qualified hydraulic mechanic or/ and an electrician. Please, contact a DYNASET authorized workshop or a dealer in case of a need for more information.

MAG	FAILURE	REASON	CORRECTIVE ACTION
	<b>HMG/CMG PRO GENERATOR IS OILY.</b>	The pressure line is connected while the return line is disconnected and the pressure relief valve leaks the oil.	Check the connection and connect the hoses to their correct places.
<b>MAGNET DOES NOT WORK</b>    Readout is displayed when magnet current is under 2A.		Magnet unplugged or magnet cable is damaged.	Switch off the generator. Check the plug to the magnet. Change the cable if it is damaged.
		Magnet is damaged.	Check the coil's resistance and compare the result to the value indicated in the magnet's manual. Check also coil's inductance if possible.
		Generator won't produce 220 VDC.	Turn off the generator. Check whether there is a DC voltage between the control card's terminals 6 and 7.  If control unit is provided with multiple control cards check the connection between different cards. Check the connection between different card terminals 6 and 7 e.g check if there is a connection between card 1 terminal 6 and card 2 terminal 6 etc. If connection is lost it has to be set back up to clear the problem.  If the connection is in order the control card is broken. Defective card(s) should be replaced.

MAG	FAILURE	REASON	CORRECTIVE ACTION
 <p>O.CUR blinks in turn with time indication countdown from 30 sec to 0 sec.</p> <p><b>!WARNING!</b> O.CUR stops the magnet immediately from magnetization. Watch out the dropping collected metals.</p>  <p>O.HEA indicated on a digital display.</p>  <p>SNUB indicated on a digital display.</p>	<p><b>MAGNET MALFUNCTIONS</b></p>	<p>Magnet shuts down by itself after magnetization is started.</p> <p>Magnet's power demand exceeds HMG PROs output. Generator gets overloaded and stopped.</p> <p>Generator's output voltage is too high causing overloading.</p>	<p>In single card use: Choose magnet according to HMG PRO's power output.</p> <p>With multiple cards: Check first the connection between terminals 6 and 7 between different cards. e.g check if there is a connection between card 1 terminal 6 and card 2 terminal 6 etc. if connection is lost it has to be repaired.</p> <p>If the connection is in order the control card is broken. Defective card(s) should be replaced.</p>
	<p>Magnet's cable shortcircuits.</p> <p>Connections in control card short circuit.</p> <p>Problem outside the generator.</p>	<p>To test the cable shut down the generator, unplug the cable and turn on the generator.</p> <p>If the generator's display shows O.CUR, problem is in the control unit's connections.</p> <p>If the generator's display blinks U.CUR/220, the problem is outside the control unit. Then check the frequency (50Hz±5%). Frequency can be measured between terminal 1 and 3 in the control box. If the frequency is ok, then the generator's hydraulics are in order.</p> <p>After this measure the AC voltage between all the phases from terminals 1-2,2-3,1-3. If the Voltage is under 170 VAC the problem is in the voltage regulator system and it needs a repair.</p>	
	<p>The generator is overheating</p>	<p>Ensure proper ventilation and clean the generator. "6.3. Cleaning the HMG/CMG PRO". Check if the fans are working in the multiple card use.</p> <p>The generator will turn back on automatically after it has cooled enough.</p>	
	<p>Failure on the control unit or in the internal wirings.</p>	<p>Measure resistance between control card terminal 8 and 9.</p> <p>If it is 12 Ohms, the problem is in the control card and it needs to be replaced.</p> <p>If it is not 12 Ohms the problem is in the resistors. If it is 24 Ohms, one resistor is broken. If it is something else both resistors are broken and need replacing.</p>	



## HYDRAULIC MAGNET GENERATORS MAINTENANCE

MAG	FAILURE	REASON	CORRECTIVE ACTION
	MAGNET MALFUNCTIONS	Low magnet power.	<p>Check VDC-voltage on the display. If ok, check magnet's resistance.</p> <p>If VDC is not ok check the frequency and AC voltage (170VAC) between all phases to the control unit between terminals 1-3. If the frequency is out of range, the problem is in hydraulic system. If the frequency is ok and the AC voltage is not, the problem is in the generator (not in the control box).</p> <p>If the frequency is ok, the problem is in the control card.</p>
	DEMAGNETIZATION DOES NOT WORK	Control cable or push button malfunction.	Lay magnet down, switch off generator. Check control cable and push button.
GEN	FAILURE	REASON	CORRECTIVE ACTION
	LOW OUTPUT VOLTAGE AT NO LOAD	Poor contact in electric system.	Check all internal contacts and wirings of the generator. Check and clean brushes and slip ring.
	OUTPUT VOLTAGE < 20Vac	Excitation rectifiers failure.	Trace the failure and replace the rectifier (with compound or Capacitor voltage regulator).
		Voltage regulators failure.	Replace the capacitor.
			Check and adjust the air gap of the compound regulator. Replace if broken.
		Check and adjust or replace the electronic regulator (HMG/CMG PRO with AVR).	
		Insufficient residual magnetism.	Use external 12 V DC battery for 1 - 2 sec. to magnetize the rotor.
	LOW OUTPUT VOLTAGE AND FREQUENCY AT LOAD	The generator is being overloaded.	Reduce the load and check the current I (A) to ensure that the proper load is being applied.
	LOW FREQUENCY AT NO LOAD	Too low rotation speed	If frequency is out of range, hydraulic system failure is concerned.
			Check whether the hydraulic flow and pressure are sufficient. Adjust RPM-cartridge if necessary.
			Check the hydraulic motor for possible leakage. Replace motor if necessary.



# HYDRAULIC MAGNET GENERATORS MAINTENANCE

GEN	FAILURE	REASON	CORRECTIVE ACTION
	<b>HIGH FREQUENCY AT LOAD</b>	Too high rotation speed	If frequency is out of range, hydraulic system failure is concerned.
			Check whether the hydraulic flow and pressure are sufficient. Adjust RPM-cartridge if necessary.
	<b>OUTPUT VOLTAGE INSTABILITY</b>	Instable rotation speed of generator	Check generator's hydraulics, including automatic frequency control valve. Make an adjustment if necessary.
			Check that the hydraulic oil Flow is constant.
			Check whether the hydraulic fluid flow and pressure are not excessive. Adjust when necessary.
			Check the hydraulic motor for possible leakage. Replace motor if necessary.
	<b>LOW OUTPUT VOLTAGE AT LOAD</b>	The generator is being overloaded.	Reduce the load and check the current I (A) to ensure that the proper load is being applied.
	<b>GENERATOR CONSUMES ABNORMAL AMOUNT OF HYDRAULIC FLUID</b>	Failure of axial sealing in generator's hydraulic motor.	Axial sealing of hydraulic motor broken by reason of excessive pressure in return line (T). Rebuild the return line (T). Maximum allowed pressure in return line is 5 bar. Replace axial sealing of generator's motor.
		External indication: hydraulic oil outflow from ventilation grids.	
		Oil leakage from hydraulic motor.	Hydraulic motor worn out and should be replaced.
	<b>GENERATOR CONSUMES ABNORMAL HYDRAULIC PRESSURE AT NO LOAD</b>	Winding failure.	One ore more stator winding is in short circuit. Replace generator.
	<b>A MILD ELECTRIC SHOCK FROM HYDRAULIC GENERATOR</b>	Poor hydraulic generator grounding.	Ensure proper grounding cable installation. READ CAPTER "4.3.2 Grounding" for more information.
	<b>ABNORMAL NOISE FROM GENERATOR</b>	Bearing failure.	Replace broken/worn bearing.
		Broken fan.	Replace broken/worn fan.



## 7. MANUFACTURER'S LIMITED WARRANTY

### 1. Warranty coverage

All hydraulic accessories manufactured by DYNASET OY are subject to the terms and conditions of this limited warranty. Products are warranted to the original purchaser to be free from defects in materials or workmanship. Exclusions from warranty are explained in item Exclusions from warranty.

### 2. Beginning of warranty period

Warranty period begins from the delivery date of the product. Delivery is considered to be done on the date when installation has been accomplished or purchaser has taken the product in use. Product is considered as taken in use at the date when DYNASET OY has delivered the product to purchaser, unless separately agreed otherwise by written agreement.

### 3. Warranty period

Warranty period is twenty four (24) months based on maximum of 2000 hours usage during this time period. In cases where the system is provided complete with certain special components (e.g. drive unit), those components are considered as a subject to their manufacturer's warranty.

### 4. Warranty procedures

Immediately upon identifying a problem which purchaser believes to be a failure subject to the product's limited warranty, purchaser must contact primary to the seller of the product. Contact must be made as soon as possible, latest thirty (30) days after the problem was identified. Seller and/or manufacturer technical staff determines the nature of the problem primarily by phone or e-mail. Purchaser commits to give necessary information and to perform routine diagnostic procedures in order to determine the nature of the problem and necessary procedures.

### 5. Warranty repairs

If the product is found to be defective during the warranty period, DYNASET OY will, at its option, either repair the product, author it to be repaired at its authorized workshop or exchange the defective product. If the product must be repaired elsewhere than premises of DYNASET OY or authorized workshop, all costs excluded from this warranty (traveling and waiting hours, daily allowance, traveling expenses and uninstallation/reinstallation costs) will be charged from the purchaser.

If the problem is not covered by this limited warranty, DYNASET OY has the right to charge purchaser of troubleshooting and repairing.

### 6. Delivery terms of warranty repair

If the product is found possible to be defective under this limited warranty and it needs to be repaired, DYNASET OY gives Warranty Return Number (WRN). Items being returned must be shipped, at the purchaser's cost, adequately packed for shipment, to the DYNASET OY or to other location authored by DYNASET OY.

Shipment documents must contain:

- Purchaser's name and contact information
- Receipt of original purchase
- WRN code
- Problem description



### **7. Warranty of repaired product**

Warranty period of the product repaired under this limited warranty continues to the end of original warranty period.

### **8. Exclusions from warranty**

This warranty shall not apply to:

- Failures due to normal wear and tear, improper installation, misuse, abuse, negligence, purchaser selection of improper product to intended use, accident, improper filtration of hydraulic oil or intake water or lack of maintenance.
- Cost of maintenance, adjustments, installation or startup.
- Coating, hydraulic oil, quick couplings and interconnection hoses (internal or external to system assemblies).
- Products altered or modified in a manner not authorized by DYNASET OY in writing.
- Products which have been repaired during warranty period by others than DYNASET OY or its authorized workshop.
- Costs of any other damage or loss, whether direct, indirect, incidental, special or consequential, arising out of the use of, or the inability to use, the product.
- Telephone or other communications expense.
- Product that is used in exceptional conditions, considered to cause excessive wear and tear.
- Faults caused by nature phenomenon's like flood, thunder, etc.

© DYNASET OY, all rights reserved



## 8. PRODUCT DISPOSAL

Dispose and recycle all DYNASET products and their packaging environmentally responsible way.

Do not dispose used oils, electrical components, batteries or any other hazardous waste with normal waste. They are harmful to the environment and can be recycled for re-use.

Contact your local waste recycling facility for more information about recycling hazardous waste.

---

**!** NOTE!

**Always act according to the waste legislation, regulations and recommendations in waste disposal and waste recycling issued by your local authorities.**

---



HYDRAULIC MAGNET GENERATORS  
PRODUCT DISPOSAL

## 9. DECLARATION OF CONFORMITY

We hereby declare that the design and manufacture of the product stated below are in conformity with the provisions of the European Parliament and Councils on the harmonization of the laws of Member States on the safety of machines.

**Machine directive 2006/42/EC**

**LVD directive 2006/95/EC**

**EMC directive 2004/108/EC**

Applied conformity standards:

**CEN EN ISO 4413: EN ISO 4413:2010** Hydraulic fluid power - General rules and safety requirements for systems and their components.

**EN60204-1** Safety of machinery – Electrical equipment of machines.

Manufacturer: **DYNASET Oy**  
Menotie 3, FI-33470 Ylöjärvi, Finland

Product group: HYDRAULIC MAGNET GENERATORS

Product: HMG PRO hydraulic magnet generator  
CMG PRO hydraulic magnet generator

If the device has been modified by someone other than the manufacturer or without the manufacturer's permission, this declaration is not valid.



---

Timo Nieminen  
R&D Manager  
Ylöjärvi, Finland 01.12.2015



HYDRAULIC MAGNET GENERATORS  
DECLARATION OF CONFORMITY

## 10. TECHNICAL SPECIFICATIONS

STANDARD MODELS		HMG/CMG PRO 3kW 17	HMG/CMG PRO 6kW 33	HMG/CMG PRO 10kW 48	HMG/CMG PRO 12kW 57
<b>OUTPUT CHARACTERISTICS</b>					
Generator power max.	<b>kW</b>	3	6	10	12
Magnet coil power max.	<b>KW</b>	0,5 - 3	0,5 - 5,5	1,0 - 9,1	1,0 - 11
Operating voltage	<b>VDC</b>	220±5%			
Auxiliary electricity		Optional			
Operating control voltage	<b>VDC</b>	6 - 32*			
<b>HYDRAULIC CONNECTION</b>					
Pressure line P	<b>P</b>	BSP 1/2"			BSP 3/4"
Return line T	<b>T</b>	BSP 1/2"			BSP 1"
Drain line D	<b>D</b>	06L - (M12x1,5 Male)			BSP 1/4"
<b>HYDRAULIC POWER REQUIREMENTS</b>					
Flow min.	<b>l / min (gpm)</b>	17 (4.49)	35 (9.24)	50 (13.2)	59 (15.58)
Flow max.	<b>l / min (gpm)</b>	37 (9.77)	53 (13.99)	68 (17.95)	77 (20.33)
Pressure at nominal power output	<b>bar (psi)</b>	150 (2176)	180 (2611)	180 (2611)	180 (2611)
Pressure max.	<b>bar (psi)</b>	210 (3046)	210 (3046)	210 (3046)	210 (3046)
Pressure when unloaded	<b>bar (psi)</b>	50 (725)	50 (725)	50 (725)	40 (580)
<b>HYDRAULIC FLUID REQUIREMENTS</b>					
Viscosity	<b>cSt</b>	10-200 / optimum 25-35			
Temperature	<b>° C(°F)</b>	max. 70 (158)**			
Filter ratio, recommendation	<b>um</b>	25 ≥			
Cooling capacity requirements ***	<b>kW</b>	1,4	2,4	3,1	3,5
<b>OVERALL DIMENSIONS</b>					
Length	<b>mm (in)</b>	402 (15.8)	520 (20.5)	575 (22.6)	570 (22.4)
Width	<b>mm (in)</b>	340 (13.4)	326 (12.8)	325 (12.8)	460 (18.1)
Height	<b>mm (in)</b>	317 (12.5)	350 (13.8)	350 (13.8)	370 (14.6)
Weight	<b>kg (lb)</b>	43 (95)	43 (95)	68 (150)	100 (220)



# HYDRAULIC MAGNET GENERATORS

## TECHNICAL SPECIFICATIONS

STANDARD MODELS		HMG/ CMG PRO 15kW 65	HMG/ CMG PRO 20kW 86	HMG/ CMG PRO 30kW 120	HMG/ CMG PRO 40kW 165
<b>OUTPUT CHARACTERISTICS</b>					
Generator power max.	<b>kW</b>	15	20	30	40
Magnet coil power max.	<b>KW</b>	14,5	19,5	29,5	39,5
Operating voltage	<b>VDC</b>	220±5%			
Auxiliary electricity		Optional			
Operating control voltage	<b>VDC</b>	6 - 32*			
<b>HYDRAULIC CONNECTION</b>					
Pressure line P	<b>P</b>	BSP 3/4"	BSP 3/4"	BSP 3/4"	BSP 3/4"
Return line T	<b>T</b>	BSP 1"	BSP 1"	BSP 3/4"	BSP 3/4"
Drain line D	<b>D</b>	BSP 1/4"	BSP 1/4"	M22x1,5	M22x1,5
<b>HYDRAULIC POWER REQUIREMENTS</b>					
Flow min.	<b>l / min (gpm)</b>	68 (17.95)	94 (24.82)	122 (32.21)	167 (44.09)
Flow max.	<b>l / min (gpm)</b>	95 (25.08)	110 (29.04)	140 (36.96)	185 (48.84)
Pressure at nominal power output	<b>bar (psi)</b>	190 (2756)	190 (2756)	190 (2756)	190 (2756)
Pressure max.	<b>bar (psi)</b>	210 (3046)	210 (3046)	250 (3626)	250 (3626)
Pressure when unloaded	<b>bar (psi)</b>	40 (580)	30 (435)	40 (580)	30 (435)
<b>HYDRAULIC FLUID REQUIREMENTS</b>					
Viscosity	<b>cSt</b>	10-200 / optimum 25-35			
Temperature	<b>°C (°F)</b>	max. 70 (158) **			
Filter ratio, recommendation	<b>um</b>	25≥			
Cooling capacity requirements ***	<b>kW</b>	3,9	4,5	7,8	8,5
<b>OVERALL DIMENSIONS</b>					
Length	<b>mm (in)</b>	820 (32.3)	875 (34.4)	993 (39.1)	1003 (39.5)
Width	<b>mm (in)</b>	512 (20.2)	512 (20.2)	515 (20.3)	600 (23.6)
Height	<b>mm (in)</b>	415 (16.3)	415 (16.3)	450 (17.7)	600 (23.6)
Weight	<b>kg (lb)</b>	145 (320)	163 (359)	175 (386)	198 (437)

Gallons are U.S. liquid gallons.

\* Only with HMG PRO

\*\* Ref. to hydraulic fluids in chapter 6.2

\*\*\* Minimum cooling capacity for the HMG/CMG PRO on the base machine.





Menotie 3  
 FI-33470 Ylöjärvi, Finland  
 tel: +358 3 3488 200  
 info@dynaset.com



**ELECTRICITY**

HG Hydraulic Generator  
 HGV POWER BOX Variable Hydraulic Generator System  
 HGV Variable Hydraulic Generator System  
 HWG Hydraulic Welding Generator  
 HGG Hydraulic Ground Power Generator



**HIGH PRESSURE WATER**

HPW Hydraulic High Pressure Water Pump  
 HPW Hydraulic Power Washer  
 KPL High Pressure Street Washing Unit  
 HPW-DUST High Pressure Dust Suppression System  
 PPL High Pressure Pipe Cleaning Unit  
 HPW-FIRE High Pressure Firefighting System  
 FP Fire Fighting Piercing Kit  
 HDF Hydraulic Drilling Fluid Pump  
 JPL High Pressure Bin Washing System  
 HSP Hydraulic Submersible Pump



**COMPRESSED AIR**

HK Hydraulic Piston Compressor  
 HKL Hydraulic Rotary Vane Compressor  
 HKR Hydraulic Screw Compressor



**MAGNET POWER**

HMG PRO Hydraulic Magnet Generator  
 MAG Lift Magnet  
 HMAG PRO Hydraulic Magnet



**VIBRATION**

HVB Hydraulic Vibra  
 HVD Hydraulic Directional Vibra  
 HRC Hydraulic Reversal Cylinder



**POWER BOOSTING**

HPI Hydraulic Pressure Intensifier  
 HPI-C Hydraulic Pressure Intensifier for Cylinder



**KNOW-HOW**

Hydraulic Power Take-off (PTO)  
 Hydraulic Power Unit Technology  
 De-Icing Technology  
 Installation Valves  
 HHK Hydraulic Grinder  
 HV/HVY Hydraulic Winch / Winch Unit

Gensco Equipment | 1-800-268-6797 | www.genscoequip.com | info@genscoequip.com

