

GENSCO

HMG

15 KW

HYDRAULIC MAGNET GENERATORS

HMG-PCI-RANGE

GENERAL INSTRUCTIONS

□ GENSCO EQUIPMENT (1990) Inc.
53 Carlaw Avenue
Toronto, Canada
M4M 2R6
Phone: 416-465-7521
Fax: 416-465-4489

□ GENSCO AMERICA INC.
5307 Dividend Drive
Decatur, Georgia 30035

Phone: 770-808-8711
Fax: 770-808-8739

Across USA Call 1-800-268-6797
E Mail: info@genscoequip.com
Internet: www.genscoequip.com
Serving industry world wide since 1919



WARRANTY

ALL ORDERS FOR PRODUCT ARE SUBJECT TO THE FOLLOWING:

Gensco Equipment (1990) Inc. warrants each product to be free from defects in material and workmanship under normal use and service. Gensco Equipment's obligation under this warranty is limited to repairing or supplying, at our option, a part or parts to replace any defective part or parts which fail, within one (1) year from date of original sale. No product shall be returned without prior authorized approval, and if authorized, the transportation charges shall be prepaid to Gensco Equipment, Toronto, Canada, or Gensco America, Decatur, GA. Unauthorized returns will not be accepted.

The provisions of this warranty shall not apply to any part or parts which have been subject to misuse, negligence or accident, or which have been repaired or altered outside of Gensco Equipment's service department in any way, so, as in the judgment of Gensco Equipment to affect adversely its performance, stability or reliability.

Gensco Equipment neither assumes nor authorizes anyone to assume for it any other obligation or liability for any loss or damage, either direct, incidental or consequential, resulting from or arising out of, or in connection with, any of its defective part or parts.

THIS WARRANTY IS EXPRESSLY IN LIEU OF ANY AND ALL OTHER WARRANTIES, EXPRESSED OR IMPLIED, INCLUDING ANY IMPLIED WARRANTY OF MERCHANT ABILITY OR FITNESS FOR A PARTICULAR PURPOSE, AND OF ANY OTHER OBLIGATION OR LIABILITY ON THE PART OF GENSCO EQUIPMENT OF ANY NATURE WHATSOEVER.

RETURN POLICY

A Returned Goods Authorization must be obtained from Gensco Equipment prior to the return of any product. All shipments to us must be sent freight prepaid. Upon inspection, should the Quality Control Department determine the product to be defective, credit will be issued accordingly.

For product returned in an "as new" condition, the restocking charges are as follows:

RETURNED FROM DATE OF ORIGINAL SHIPMENT	STOCK ITEMS	SPECIAL ORDER ITEMS
120 Days	20%	50%

GENERAL NOTES

DYNASET hydraulic magnet generator of HMG-range, designed for an installation to material handling machines (hydraulic excavators, heavy trucks with hydraulic cranes), is compact and complete power source for ferrous metal handling magnet. The only power source is a hydraulic system to provide generator with required hydraulic fluid flow at demanded pressure.

DYNASET hydraulic magnet generator transforms hydraulic power into a high quality electricity, which is used for energising metal handling magnet. HMG-PCI units are provided with an external electric control.

An automatic demagnetisation ensures fast disengagement of a picked and moved metal off from a magnet. DYNASET HMG-generators operates with all 220 VDC metal handling magnets upon condition that magnet's coil inductance is 0 ... 20 H.

CONSTRUCTION

DYNASET hydraulic magnet generator is comprised of hydraulic synchronous generator and electric control unit which includes a rectifier block and operation control automatics. The power-to-weight ratio of DYNASET hydraulic magnet generator is excellent due to modern mono-bearing construction when the other end of rotor's shaft is supported by hydraulic motor. (Generators over 15 kVA are bi-bearing units).

The unit has an automatic rotation speed control valve with ports for pressure and return lines.

Unit's rotor, connected to the hydraulic motor's shaft, is provided with an excitation windings. Electric power is taken from stator windings. Auxiliary winding of voltage control system is located in generator's stator as well. Windings are isolated from unit's body and their insulation class is H.

Protection class of DYNASET hydraulic magnet generator in standard execution complies with specifications IP23, electric control unit meets requirements of IP44. Units with (higher ?) protection class IP 54 are available by request.

AC-auxiliary electricity is optional (standard in HMG 3,0 kW).

Automatic circuit breakers protect unit from overload.

DYNASET hydraulic generators are self-excited.

DYNASET hydraulic generator is assembled in lightweight aluminium alloy molded case with footing for fixing.

AUTOMATIC VOLTAGE CONTROL

Automatic voltage regulator adjusts rotor's excitation power, maintaining constant output voltage at discontinuous electric load.

Voltage control function depends on the rotor's rotation speed, so that the nominal voltage value is being set at the nominal frequency.

Subject to unit size, three types of voltage regulator are applied.

Voltage control of HMG 3 kW is effected with a capacitor circuit, connected to an auxiliary winding.

Voltage control keeps the voltage constant through the whole load range with accuracy of $\pm 6\%$.

Performance speed of voltage control is less than 0,1 sec.

All other HMG-units are equipped either with a compound or electronic voltage regulator.

Compound regulator is connected to the auxiliary winding and maintains the output voltage constant through the entire load range with accuracy of $\pm 5\%$. Compound regulator sets the excitation current according to electric load of each phase with its separate current windings individually. Each phase can be loaded up to maximum current deliberately.

Performance speed of a compound voltage controls is less than 0,1 sec.

Electronic voltage regulator is connected to the stator's and separate excitation generator's windings and achieves an accuracy of $\pm 3\%$.

Electronic voltage regulator constantly compares output voltage to the pre-adjusted reference value and sets the excitation current according the load.

Performance speed of an electronic voltage controls is less than 0,1 sec.

Automatic frequency control valve is to keep rotation speed and ($\pm 5\%$) when incoming hydraulic oil flow (Q) can vary from minimal up to value exceeding Q_{min} by 10 - 30 l/min depending on generator size.

Voltage regulator maintains the voltage constant at constant rotor's rotation speed.

$$Q_{min} = Q_{nom} + 1...5 \text{ l/min}$$

Q_{min} - minimal flow

Q_{nom} - nominal flow

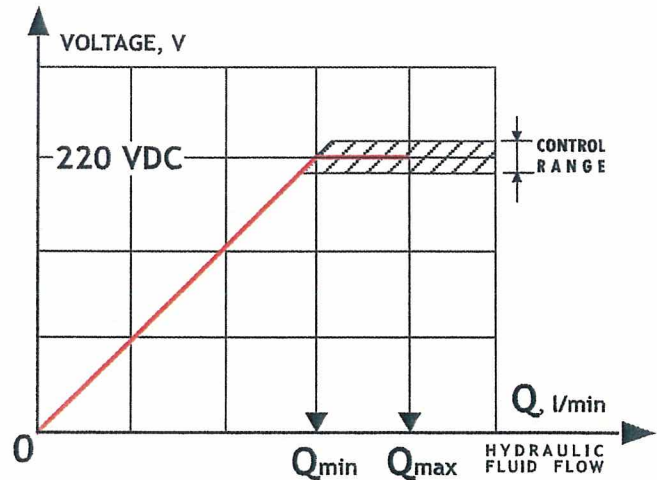

CLASSIFICATION

DYNASET hydraulic generators are manufactured in conformity with the 98/37, 73/23, 89/336 CEE directives and their amendments. They are also manufactured in compliance with the following regulations: CEI 2-3, EN 60034-1, IEC 34-1, VDE 0530, BS4999-5000, CAN/CSA-C22.2, NF 51.100 and N°14-95 - N°100-95. By request DYNASET hydraulic generators can be equipped with a radio interference protection to meet requirements of specifications MIL STD 461 A/B and VDE 0875 class N.

INSTALLATION

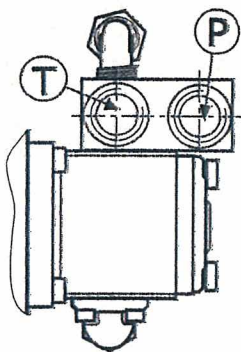

DYNASET hydraulic magnet generator works being integrated into an original hydraulic system of a material handling machine.

Unit can be placed deliberately ensuring an easy access to the unit. Generator should be positioned horizontally. Additionally, return line must be connected to a hydraulic oil tank in the shortest possible way in order to keep return oil pressure under 5 bar. Cooling capacity of hydraulic system, designed for continuous operation (an excavator), is generally sufficient under proper installation of HMG-generator. An additional oil cooler is required when HMG-unit is installed to a truck with and hydraulic hoist. Ensure that the filtration capacity of a hydraulic system is sufficient.

To enable putting DYNASET generator into operation only pressure- (P) and return (T) lines are to be connected to the hydraulic system.

Ensure that the hydraulic fluid flow is sufficient to run the unit, i.e. at least the minimal flow must be available. At the hydraulic flow less that demanded nominal rate the generator will not work properly at all. If the hydraulic flow is so excessive, that the automatic speed control valve is unable to handle it, the unit begins to hunt. In the latter case the hydraulic flow is to be reduced either by replacing an existing hydraulic pump with a suitable one or using flow limiter. **DYNASET PRIORITY VALVE is recommended.**

After having been connected to the hydraulic system, DYNASET hydraulic magnet generator is to be started by directing the hydraulic flow to the unit's pressure port by means of control valve - manual or solenoid. Even simple ball valve or three-way valve can be used.

To ensure DYNASET's proper operation, the hydraulic pressure must be set at least to the level, at which the nominal power output is achieved (ref. to PARAMETERS). Lower pressure reduces output power. Maximum hydraulic pressure is 250 bar (ref. to PARAMETERS). If the hydraulic system main pressure is higher, service pressure relief valve must be used.

Ensure also that your machine's hydraulic fluid cooling is working properly when DYNASET magnet generator is in operation.

DYNASET HYDRAULIC GENERATORS ARE DESIGNED FOR EASY INTEGRATION INTO HYDRAULIC SYSTEM OF ANY TYPE:

1. OPEN CENTRE HYDRAULIC SYSTEM WITH VARIABLE DISPLACEMENT PUMP

The demanded hydraulic flow is to be ensured and controlled with a DYNASET PRESSURE COMPENSATED PRIORITY VALVE.

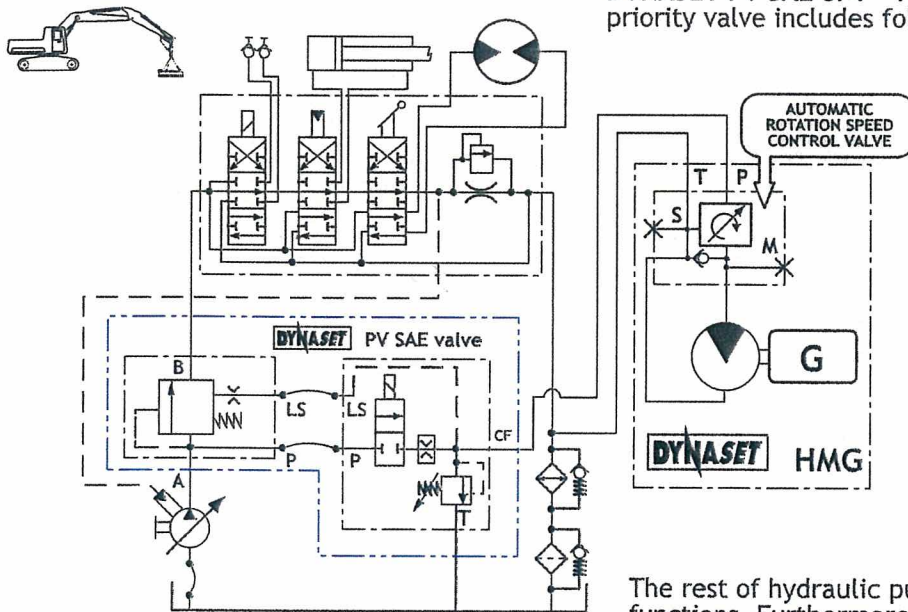

DYNASET PV SAE 3/4 - 1 1/4 -XX lpm - 12/24 V priority valve includes following components:

1. Sandwich-mounted pressure compensator with SAE-flange specification;
2. Solenoid valve 12/24V;
3. Flow limiter;
4. Pressure relief valve.

PV SAE priority valve is designed for the installation to main pressure line between SAE-flanges of main hydraulic pump. Pre-adjusted, independent from other functions and prioritised hydraulic flow for DYNASET-unit comes from the solenoid valve.

The rest of hydraulic pump's capacity is available for all other functions. Furthermore, pump's control works together with DYNASET PV SAE priority valve.

ALSO AVAILABLE for open centre hydraulic systems with variable displacement pump: PRIORITY VALVE PV C3C 3/4 - 1 1/4 - 12/24 V.

DYNASET PRIORITY VALVES enable to operate your DYNASET-unit simultaneously with other hydraulic executors.

2. CLOSED CENTRE HYDRAULIC SYSTEM WITH VARIABLE DISPLACEMENT PUMP

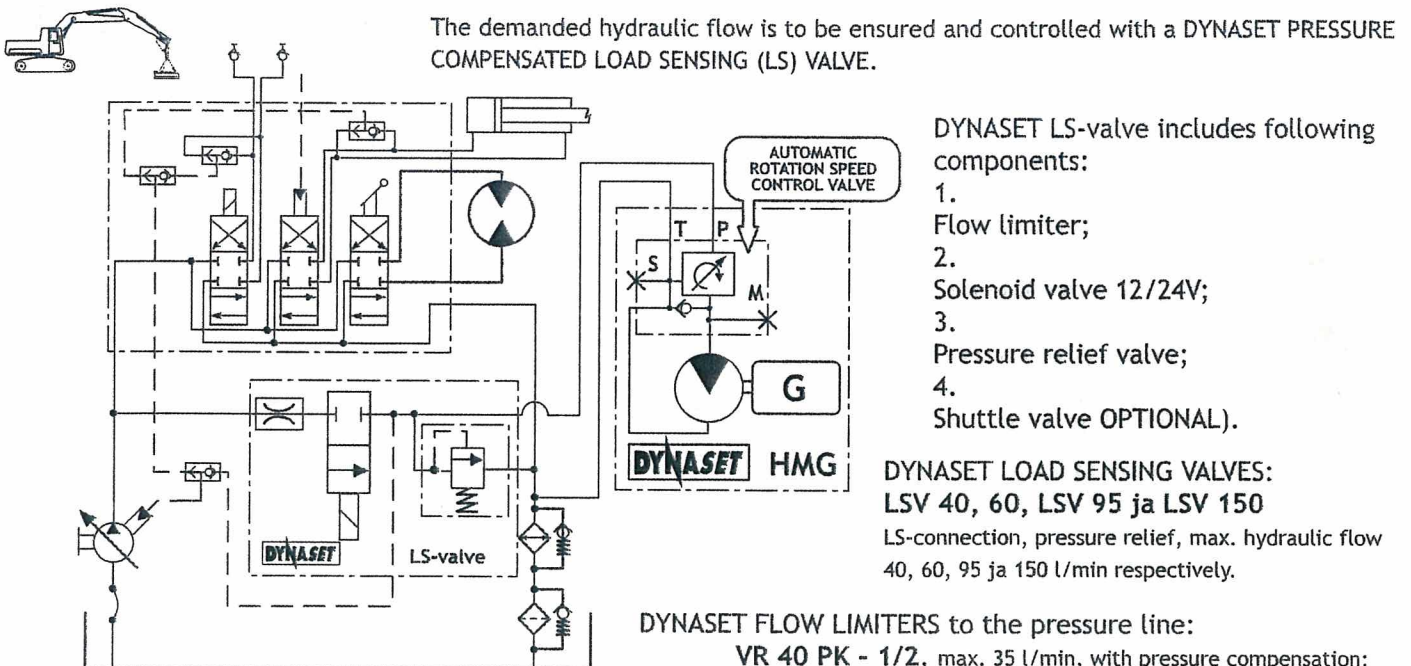

The demanded hydraulic flow is to be ensured and controlled with a DYNASET PRESSURE COMPENSATED LOAD SENSING (LS) VALVE.

DYNASET LS-valve includes following components:

1. Flow limiter;
2. Solenoid valve 12/24V;
3. Pressure relief valve;
4. Shuttle valve (OPTIONAL).

DYNASET LOAD SENSING VALVES:
LSV 40, 60, LSV 95 ja LSV 150

LS-connection, pressure relief, max. hydraulic flow 40, 60, 95 ja 150 l/min respectively.

DYNASET FLOW LIMITERS to the pressure line:

- VR 40 PK - 1/2, max. 35 l/min, with pressure compensation;
- VR 95 PK - 3/4, max. 95 l/min, with pressure compensation.

ALSO AVAILABLE for closed centre hydraulic systems with variable displacement pump:

DYNASET SOLENOID VALVE to the pressure line for remote starting.

SV 70 NC - 1/2 - 12 / 24 V

max 70 l/min with LS -connection;

SV 150 NC- 1 - 12 / 24 V

max 150 l/min with LS -connection.

1. HYDRAULIC SYSTEM WITH CONSTANT DISPLACEMENT PUMP

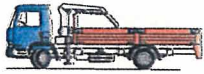

The demanded oil flow is to be ensured with proper hydraulic pump choice. In systems with redundant hydraulic flow an installation with DYNASET PRIORITY VALVE is recommended.

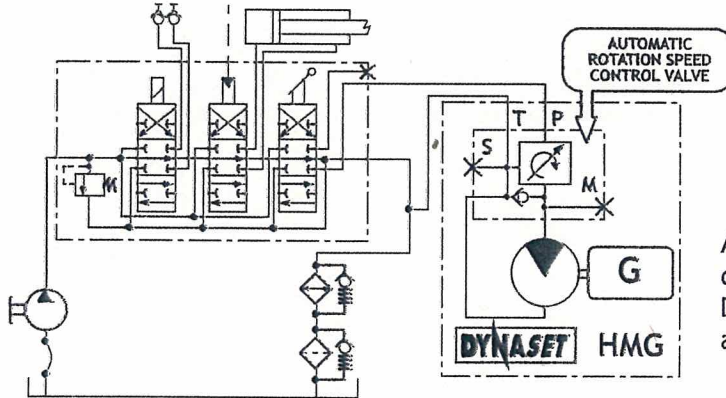

Installation with a standard pressure compensated 3-way valve should be avoided in order to close off potential waving in hydraulic system.

ALSO AVAILABLE for hydraulic systems with constant displacement pump:
DYNASET FREE-CIRCULATION VALVE with solenoid and pressure control, type VKV 90-3/4.

ELECTRIC INSTALLATION KITS TO HMG MAGNET GENERATORS

Having fitted mechanically a generator to your carrier, accomplish an electric connection. Along with DYNASET HMG-generator following wiring kits can be purchased:

1. MAGNET WIRING KIT
2. HMG CONTROL WIRING KIT

1. MAGNET WIRING KIT

1.1 Magnet's cable 5m with plug.

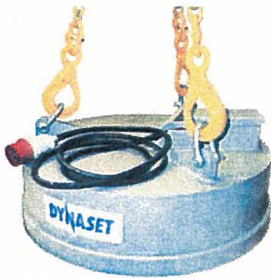

1.2 Socket with a protective cover, to be fitted to a stub boom.



1.3 Cable 20 m from beam's socket to a generator's socket, with plug.

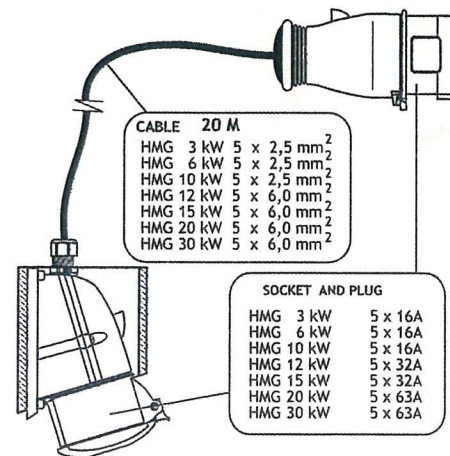
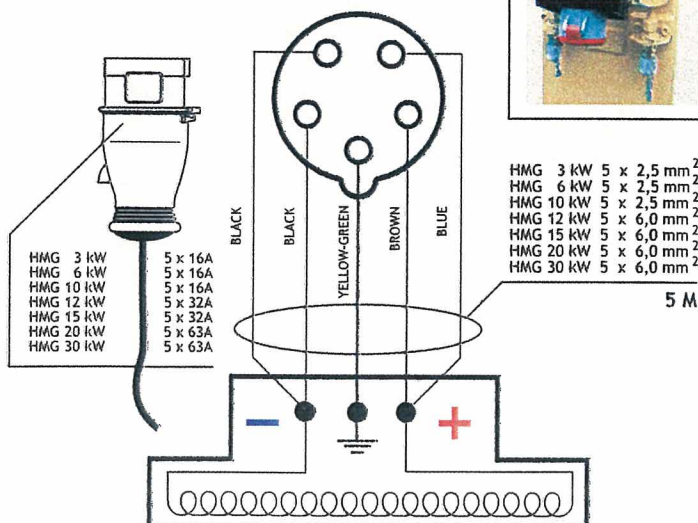
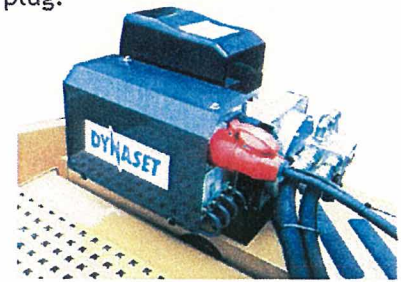

OPERATION

After ensuring the proper operation of the generator, plug magnet's cable to generator's socket.
Start machine's engine.

Direct the hydraulic flow to a generator by opening a solenoid valve, when the control voltage 12/24V, brought to the control unit, activates (ref. HMG CONTROL WIRING KIT on a previous page). Magnet is ready for use when hydraulic flow achieves a minimal demanded level.

Generator rotates constantly the pressure line being open.

Magnet's current is switched on by pressing magnet's control push-button once for app. 1 sec, when material is to be picked and moved. Magnetisation indicator light is ON.

Press the push-button sequently to cut-off magnet's current (magnetisation indicator light is OFF) and to turn on the reverse current, when a residual field discharges due to demagnetisation and all material being kept by a magnet drops down. During a demagnetisation an indication light flashes once. Duration of the second pressing affects the demagnetisation power. Keeping the push-button pressed down magnet's demagnetisation is being forced to ensure complete release of a material. Generally discharge time is 2 - 3 sec subject to magnet.

After release of a material, magnet is returned to an iron picking point and the job continues in above sequence.

Magnetisation and demagnetisation of a magnet is controlled by PCI-card, located in HMG's control unit. Control is effected according to push-button's impulses by means of contactors K1, K2 and K3, also located in control unit's enclosure. Contactor status is indicated with LEDs found on a PCI-card.

METAL HANDLING MAGNET'S CONTROL SEQUENCE

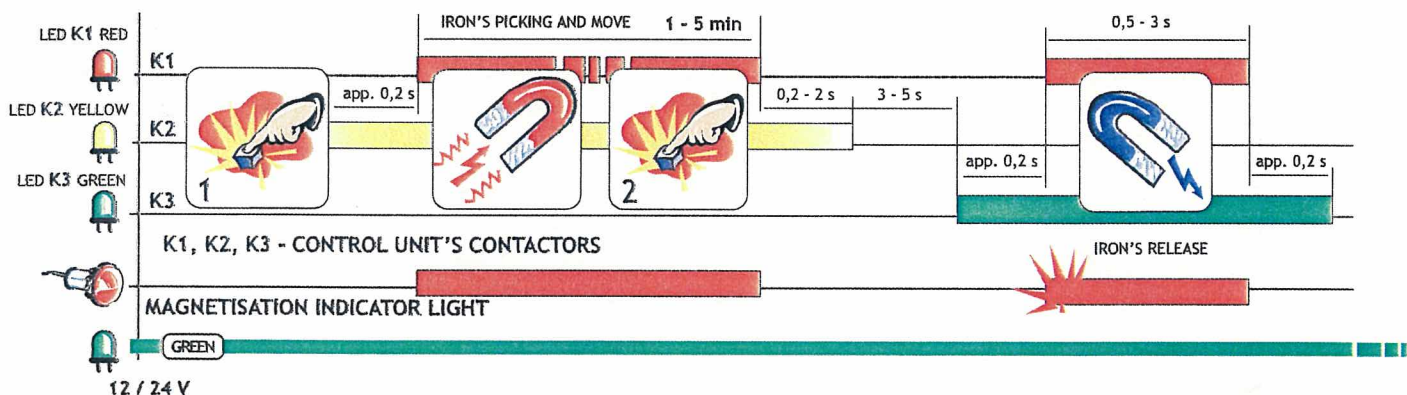

ATTN! LEDs K1, K2 AND K3 ARE LOCATED IN CONTROL UNIT'S ENCLOSURE.

- | | | | |
|---------------------|---------|-------------------------|------------------|
| PUSH-BUTTON IMPULSE | 0,2 sek | (app. 1 s when testing) | |
| CONTACTOR K1 | ← | ENGAGED | DELAY app. 0,2 s |
| CONTACTOR K2 | ← | ENGAGED | |

CONTACTORS K1 and K2 are kept engaged;

MAGNET IS ON...

- | | | | |
|---------------------|---------|-------------------------|------------------|
| PUSH-BUTTON IMPULSE | 0,2 sek | (app. 1 s when testing) | |
| CONTACTOR K1 | → | DISENGAGED | DELAY 0,2 - 2 s |
| CONTACTOR K2 | → | DISENGAGED | DELAY 1 - 5 s |
| CONTACTOR K3 | ← | ENGAGED | DELAY app. 0,2 s |
| CONTACTOR K1 | ← | ENGAGED | |

DEMAGNETISATION BEGINS...

- | | | | |
|--------------|---|-----------------|------------------|
| | | DELAY 0,5 - 3 s | |
| CONTACTOR K1 | → | DISENGAGED | DELAY app. 0,2 s |
| CONTACTOR K3 | → | DISENGAGED | |

Hydraulic pressure is being adjusted according to the magnet's power demand, when the hydraulic fluid flow is being kept constant.

DYNASET hydraulic magnet generator produces high quality electric power within pressure range from idle run pressure to the maximum allowed value. The nominal power output is achieved at pressure value, which is noticeably less than the maximum allowed operation pressure. Refer to the attached diagram and technical specifications.

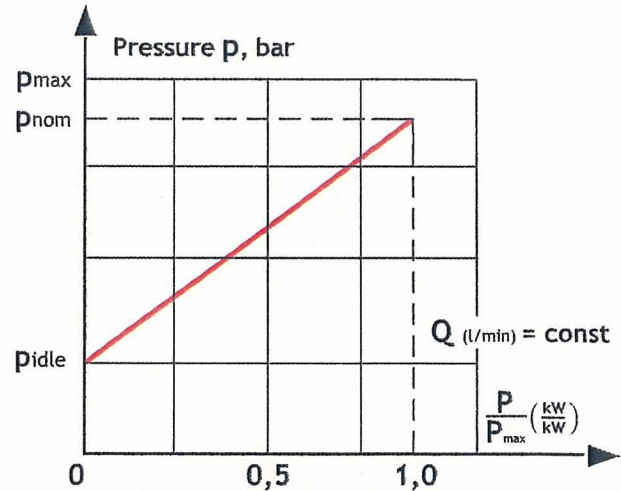

ATTN !

HMG generator is equipped with an overload circuit breaker as well as with a temperature switch. At overload the circuit breaker switches off magnet's current without demagnetisation. However, the iron comes off for a long while causing dangerous situation. **NEVER STEP TO THE AREA UNDER LOADED MAGNET !** Having rectified a problem, reset the circuit breaker with its pushbutton or switch.

Temperature switch cuts off magnet's current without demagnetisation when control unit's temperature exceeds maximum allowed value. Generator can be left running in order to cool it as fast as possible. The unit being cooled enough, temperature switch turns on the magnet's current automatically, when an operator can proceed with his job.

ATTN !

Magnet's load duty is 60%. Exceeding of ED-value causes magnet's overheating !

MAINTENANCE

DYNASET hydraulic generators are low-maintenance units. Only normally wearing parts such as sealings in hydraulics, brush collector and bearings should be replaced when necessary. Refer also to the TROUBLESHOOTING section.

ATTN. !

Capacitors in control unit keep the charge for a long time after stopping a generator.

Prior to commence any service:

- * stop both magnet generator and the carrier
- * wait at least 10 minutes
- * ensure with a gauge that capacitors have no charge.

ATTN. !

CLEANLINESS OF YOUR HMG-UNIT MUST BE MAINTAINED ON A REGULAR BASIS. CHECK YOUR EQUIPMENT AFTER EVERY WORKING SHIFT AND DEPENDING ON AN OPERATIONAL ENVIRONMENT CLEAN A GENERATOR AS FREQUENTLY AS NECESSARY TO KEEP IT IN PERFECT WORKING CONDITION.

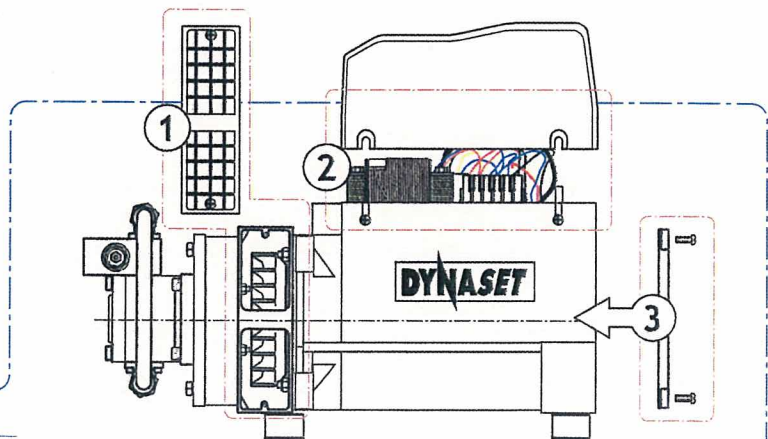

Use blow gun with a **REASONABLE DELIBERATION** to dust your equipment.

Remove side screens (1) and air diffuser (3) to clean fan compartment as well as rotor and stator. Remove cover (2) to dust alternator's electric components. Having dusted/cleaned the generator, replace screens/covers and secure them with appropriate screws. (Above picture for reference only - refer to the data pages of specific HMG-model).

Remove all oil deposits. Remove all unnecessary grease and oil from the unit. Accumulated grease and oil can cause overheating and subsequent generator damage and may present a potential fire hazard. Do not leave in the generator case or control box anything which does not belong to the assembly.

The tightness of lids and covers as well as of all screw joints must be inspected on a regular basis, for instance at least once a week or more frequently, if a generator is exposed to a noticeable vibration.

Having carried a maintenance or cleaning, NEVER LEAVE ALTERNATOR'S COVER AND/OR ELECTRIC BOX' COVER UNREPLACED AND UNSECURED ! Condition of any seal/gasket must be inspected and defective parts replaced.

HYDRAULIC FLUIDS

Wide range of standard hydraulic fluids can be used with the DYNASET hydraulic equipment.

Subject to the operating temperature, following mineral hydraulic oils are recommended:

ISO VG 32S for oil's operation temperature up to 70 °C;

ISO VG 46S for oil's operation temperature up to 80 °C;

ISO VG 68S for oil's operation temperature up to 90 °C.

Synthetic and bio-oils can be used as well if their viscosity characteristics and lubricating efficiency are corresponding to above mineral oils. Automatic transmission fluids and even engine oils can be used, provided that they are allowed to be used in hydraulic system of your carrier machine.

Prior to use special hydraulic fluids a with DYNASET equipment, please be kindly requested to contact nearest DYNASET representative for an advice.

SAFETY

The generator's output voltage is as high as 230/400 V. Operators and maintenance personnel must always comply with local safety regulations and precautions in order to close out the possibility of damages and accidents. Prior to detaching a magnet from a carrier, unplug it from a generator's socket ! Capacitors of control unit can discharge developing voltage over 200V even the equipment stands still.

The hydraulic system is usually pressurised up to 250 (420) bar. Follow all your local safety instructions related to the high pressure hydraulics.

TECHNICAL CONDITION OF YOUR MACHINERY AND EQUIPMENT MUST BE SUBJECTED TO CONSTANT SURVEILLANCE. Hydraulic system of a carrier machine should be maintained according to the service program. All couplings, valves and hoses of the system should be leak-proof and kept clean in order to follow their technical condition. Hydraulic leakages must be rectified immediately to avoid injuries caused by hot oil blowouts.

Prior to maintenance, detaching from a carrier or disassembling a DYNASET-unit, the hydraulic system of a machine should be stopped and DYNASET's hydraulic circuit depressurised.

When working with a DYNASET hydraulic equipment, appropriate protective clothing, safety goggles and gloves should be worn. Do not touch parts heated by hydraulic oil.

WHEN CARRYING OUT ANY SERVICE DISASSEMBLING OR REPAIR OF DYNASET HYDRAULIC UNIT (AND/OR HYDRAULIC SYSTEM OF A CARRIER MACHINE), ABSOLUTE CLEANLINESS MUST BE MAINTAINED TO ENSURE RELIABLE AND TROUBLE-FREE OPERATION OF YOUR EQUIPMENT.

All installation and service of both hydraulic and electric equipment must be performed by qualified and experienced personnel only.

WARRANTY

DYNASET products are warranted against defects in materials and workmanship for a period of 6 (six) months from the date of purchase. Exceptions are parts subject to normal wear and tear, such as seals and other parts that become worn through normal use of the unit.

Warranty covers detective parts solely. Expenditure incidental to shipping and replacement are not covered by present warranty.

The warranty is void if product has been modified, provided with parts other than original or misused.

TROUBLESHOOTING

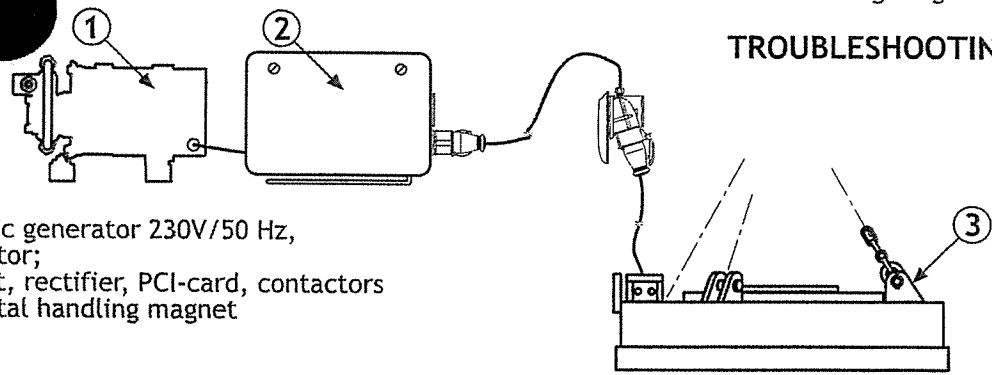

1. AC-hydraulic generator 230V/50 Hz, RPM-regulator;
2. Control unit, rectifier, PCI-card, contactors
3. Ferrous metal handling magnet

<p>1. MAGNET DOES NOT WORK</p>	<p>1.1 Magnet unplugged or magnet's cable damaged. Red failure indication LED on PCI-card is ON.</p> <p>1.2 220 VDC voltage does not come from the control unit to magnet's terminals.</p> <p>1.3 AC-voltage does not come from generator to the control unit.</p> <p>1.4 Malfunction in contactor' K1 and K2 control. The contactors must be engaged.</p> <p>1.5 Contactor's K2 breaker points are worn.</p> <p>1.6 Magnet's coil is damaged.</p>	<p>1.1 Replug the magnet; change the cable if damaged.</p> <p>1.2 Contactor's K1 breaker points are worn. Check their resistance when the contactor is engaged. Correct value is 0,2 Ohm.</p> <p>Rectifier's diode bridges (HMG3 kW) or diodes (HMG6 -...) short-circuited or blown. Check diode bridges / diodes. Proceed as follows (ref. to electric diagram) : + diodes: K1/L1 - K2/L1; K1/L2 - K2/L1; K1/L3 - K2/L1. - diodes: K1/L1 - K2/L3; K1/L2 - K2/L3; K1/L3 - K2/L3. ATTN ! When checking diodes, generator must be stopped. Measuring procedure does not require detaching diodes from a control unit. Replace damaged components.</p> <p>Magnet's cable damaged.</p> <p>1.3 Check whether there is a 3-phase voltage 150 - 180 VAC on terminals T1, T2 and T3 of contactor K1. Potential malfunction in hydraulic system. Potential failure in AC-generator's windings, brush gear, excitation rectifier or voltage regulator. Ref. to the attached troubleshooting for AC-generator.</p> <p>1.4 Check control wiring, especially magnet's push-button and generator's starting switch. Check the PCI-card, replace the fuse if blown. Test contactor' operation: press the magnet's control push-button and follow LEDs sequence (ref. to the item OPERATION). Replace the PCI-card if damaged. Ref. also to the attached instructions for PCI-card.</p> <p>1.5 Check resistance of breaker points when the contactor is engaged. Correct value is 0,2 Ohm.</p> <p>1.6 Check coil's resistance and compare the result to the value indicated in the table thereafter. Check also coil's inductance if possible.</p>
---------------------------------------	--	--

<p>2. IRON DOES NOT GET RELEASED FROM A MAGNET (DEMAGNETISATION DOES NOT WORK)</p>	<p>2.1 Contactor's K1 and K3 do not operate in correct sequence.</p> <p>2.2 Contactor's K3 breaker points are worn.</p>	<p>2.1 Test contactor' operation: press the magnet's control push-button and follow LEDs sequence (ref. to the item OPERATION). Replace the PCI-card if damaged. Ref. also to the attached instructions for PCI-card.</p> <p>2.2 Check resistance of breaker points when the contactor is engaged. Correct value is 0,2 Ohm.</p>
--	---	--

<p>3. MAGNET MALFUNCTIONS.</p>	<p>3.1 Magnet keeps working only a short time.</p> <p>3.2 Low magnet's power.</p> <p>3.3 Magnet's power consumption excessive, automatic circuit breaker stops the generator.</p>	<p>3.1.1 Magnet's power demand exceeds HMG's output. Generator gets overloaded and stopped by an automatic circuit breaker. Choose magnet according to HMG's power output.</p> <p>3.1.2 Magnet's cable's short-circuit. Automatic circuit breaker stops the generator. Unplug the magnet; if circuit breaker does not trip shortly after starting the generator, cable is damaged.</p> <p>3.1.3 Control unit overheated. Control unit's thermostat switch tripped by reason of L-resistor's failure. Insufficient cooling.</p> <p>3.2 Magnet's voltage too low: Does DC-voltage come to magnet's terminals ? Does AC-voltage comes to the control unit ? Check AC-generator according the attached instructions; Check actuating hydraulics.</p> <p>3.3 Generator's output voltage too high causing overloading. Check AC-generator according the attached instructions; Check actuating hydraulics. Adjust the output voltage to proper level. ATTN ! High voltage is hazardous to a generator. Rectify a malfunction immediately.</p>
--	---	---

MAGNET'S RESISTANCE		
	Ω (Ohm)	
	min	max
HMG 3 kW	15	50
HMG 6 kW	8,8	20
HMG 10,0 kW	5,4	15
HMG 12,0 kW	4,5	10
HMG 15,0 kW	3,6	8
HMG 20,0 kW	2,6	6
HMG 30,0 kW	1,7	5

PCI - CONTROL CARD

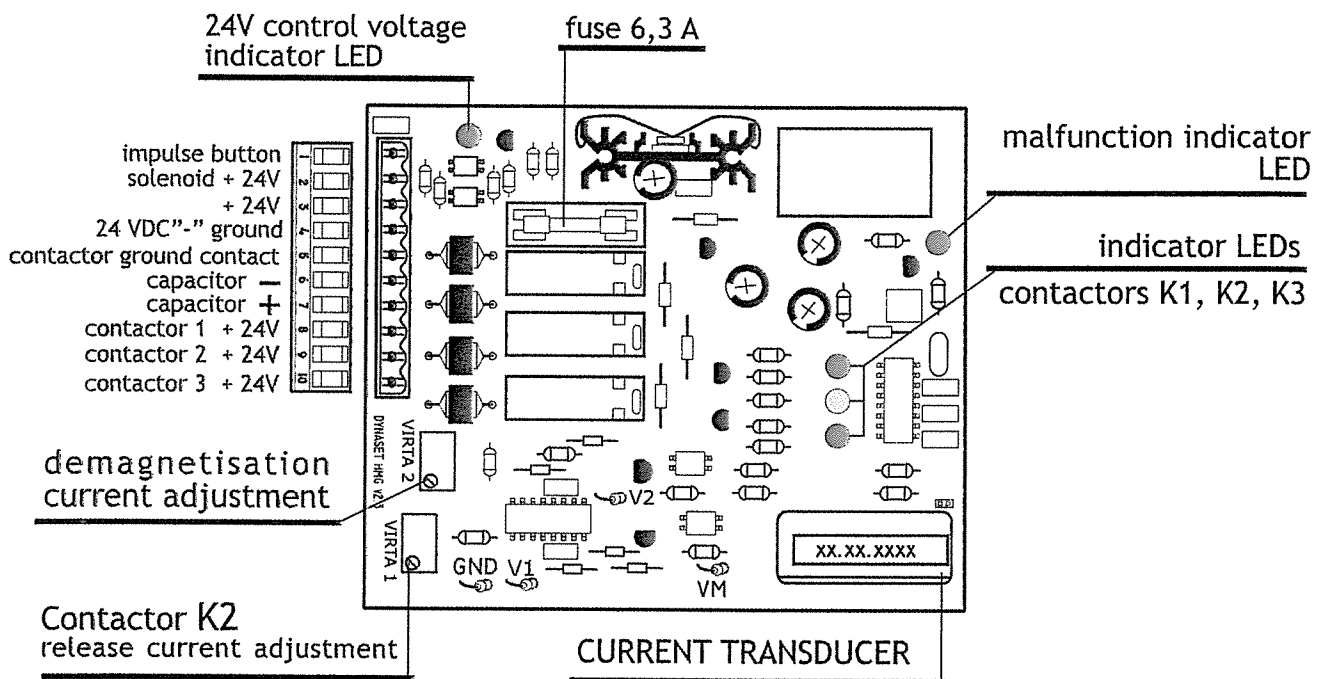

1. CONTROL VOLTAGE LED 24 V (GREEN) activates when the main switch is turned ON.

If the LED is off, either the control wire is damaged or the fuse (6,3 A) has blown.

2.

LED indicators for contactors K1, K2 and K3.

Contactor K1	Colour RED
Contactor K2	Colour YELLOW
Contactor K3	Colour GREEN

When contactor is engaged, the corresponding LED is ON.

If LED is ON, but the contactor still disengaged, whether contactor's coil or wire is damaged.

If LEDs are off constantly, the PCI-card does not work properly.

3.

MALFUNCTION INDICATOR LED Colour RED

The concerned LED indicates control voltage failure and malfunction of magnet current metering circuit.

If LED is continuously ON when working:

- 3.1 Magnet cable is disconnected or damaged.
- 3.2 Current metering circuit of PCI-card damaged or the PCI-card is not adjusted properly (check the set value of potentiometers VIRT A1 and VIRT A2).
- 3.3 If led keeps flashing after working cycle, the wire of 24V has poor contact.

The LED starts flashing when 24V voltage cuts off for longer time than 0,2 s.

SAFE MODE

PCI CONTROL CARD runs in safe mode when a failure occurs. MALFUNCTION INDICATOR LED is ON continuously, but the job can be continued without immediate tracing and rectifying the failure. In SAFE MODE fixed demagnetisation time is 6 sec, however magnet's considerable inductance may extend the above time with 1 - 3 seconds.

The PCI card runs in SAFE MODE when the HMG-generator is ON, but the magnet cable is disconnected.

**ADJUSTING THE INDUCTION CURRENT ON MAGNET TO DISENGAGE CONTACTOR K2
POTENTIOMETER VIRT A1**

PCI-card measures automatically the inductive current and disengages the contactor K2 at the right time without arcing, regardless of magnet inductance (0 - 20 H) and power.

Adjusted induction current value can be gauged with mV-meter (1 mV = 0,001 V) between measure points V1- and GND of the card, when the control voltage 24V is ON.

On condition that 1 A = 40 mV and factory default of 300 mV, current value makes 7,5 A.

To speed up the opening time of contactor K2, V1-value can be increased to 330 mV (= 8,3A) by setting the potentiometer VIRT A1 counter-clockwise (max. 1 rev. = 30 mV. DO NOT increase too much because that reduces the service life of contactor K2.

**ADJUSTING THE DEMAGNETISATION CURRENT
POTENTIOMETER VIRT A2**

Adjusted demagnetising current value can be gauged with mV-meter between measure points V2- and GND of the card, when the control voltage 24V is ON.

Factory default is -100 mV (= 2,5 A). Demagnetising can be increased upto -130 mV (=3,25 A) by setting the potentiometer VIRT A2 clockwise (1 round = 30 mA).

GAUGING THE MAGNET'S CURRENT

When the magnet is connected and energised, the current can be gauged between measure points VM- and GND of the card.

Factory default scale is 1A = 40 mV (i.e. magnet current of 10A is gauged as 400 mV).

AC-GENERATOR'S TROUBLESHOOTING

<p>1. LOW OUTPUT VOLTAGE AT NO LOAD</p>	<p>1.1 Too low rotation speed of generator.</p> <p>1.2 Excitation rectifier's failure.</p> <p>1.3 Poor contact in electric system.</p> <p>1.4 Voltage regulator's failure.</p> <p>1.5 Winding failure.</p>	<p>1.1.1 Check first the output frequency. If the frequency is out of range, hydraulic system failure is concerned.</p> <p>1.1.2 Check whether the hydraulic fluid flow and pressure are sufficient. Adjust when necessary.</p> <p>1.1.3 Check the hydraulic motor for possible leakage. Replace motor if necessary.</p> <p>1.2 Trace the failure and replace the rectifier.</p> <p>1.3 Check all internal contacts and wiring of the generator. Check and clean brushes and slip ring (HMG6 – HMG20 kW).</p> <p>1.4.1 Replace the capacitor (HMG 3 kW).</p> <p>1.4.2 Check the compound regulator. Replace if broken (HMG6 – HMG20 kW).</p> <p>1.4.3 Check and adjust or replace the electronic regulator (HMG30 kW).</p> <p>1.5 Check the condition of winding; verify winding's resistance with parameters shown in technical specification and replace if damaged. ATTN ! To avoid damaging the control unit set the overload protection switch to OFF-position prior to measuring winding's insulation resistance.</p>
<p>2. LOW OUTPUT VOLTAGE AT LOAD, WHILE NO-LOAD VOLTAGE IS CORRECT</p>	<p>2.1 The generator is being overloaded.</p> <p>2.2 Too low rotation speed of generator.</p> <p>2.3 Voltage regulator's failure.</p>	<p>2.1 Reduce the load and check the current I (A) to ensure that the proper load is being applied.</p> <p>2.2.1 Hydraulic pressure insufficient.</p> <p>2.2.2 Hydraulic system failure to be traced and cleared.</p> <p>2.2.3 Hydraulic motor worn out. Replace hydraulic motor.</p> <p>2.3.1 Replace the capacitor (HMG 3 kW).</p> <p>2.3.2 Check and adjust or replace the compound regulator. (HMG6 – HMG20 kW). Check resistors of rotor's current circuit (2 pcs).</p> <p>2.3.3 Check and adjust or replace the electronic regulator (HMG30 kW).</p>

AC-GENERATOR'S TROUBLESHOOTING

<p>3. EXCITATION FAILURE</p>	<p>3.1 Rectifier's failure.</p> <p>3.2 Voltage regulator's failure.</p> <p>3.3 Winding failure.</p> <p>3.4 Poor contact in electric system.</p> <p>3.5 Insufficient residual magnetism.</p>	<p>3.1 Trace the failure and replace the rectifier.</p> <p>3.2.1 Replace the capacitor (HMG3 kW).</p> <p>3.2.2 Check and adjust or replace the compound regulator (HMG6–HMG20 kW).</p> <p>3.2.3 Check and adjust or replace the electronic regulator (HMG30 kW).</p> <p>3.3 Verify the winding resistance with parameters shown in technical specification and replace if damaged.</p> <p>3.4 Check all internal contacts and wiring of the generator. Check and clean brushes and slip ring (HMG6 – HMG20 kW).</p> <p>3.5 Use external battery of 12 V for 1 - 2 sec to magnetise the rotor.</p>
--	---	---

<p>4. OUTPUT VOLTAGE INSTABILITY</p>	<p>4.1 Instable rotation speed of generator.</p> <p>4.2 Electronic voltage regulator's failure (HMG30 kW).</p> <p>4.3 Poor contact in electric system.</p>	<p>4.1.1 Check generator's hydraulics, including automatic frequency control valve. Make an adjustment, replace RPM-cartridge if necessary.</p> <p>4.1.2 Check whether the hydraulic fluid flow and pressure are excessive. Adjust when necessary.</p> <p>4.1.3 Check the hydraulic motor for possible leakage. Replace motor if necessary.</p> <p>4.2 Adjust stability of the regulator. Replace if broken.</p> <p>4.3 Check all internal contacts and wiring of the generator. Check and clean brushes and slip ring (HMG6 – HMG20 kW).</p>
--	--	---

PARAMETERS		PCI-MODELS						
		HMG 3 kW 20 VDC-17	HMG 6 kW 220 VDC-30	HMG 10 kW 220 VDC-44	HMG 12 kW 220 VDC-52	HMG 15 kW 220 VDC-65	HMG 20 kW 220 VDC-92	HMG 30 kW 220 VDC-120
POWER CHARACTERISTICS								
Generator power, max.	kW	3,0	6,0	10,0	12,0	15,0	20,0	30,0
Magnet coil power, max.	kW	3,0	5,5	9,5	11,5	14,5	19,5	29,5
Operation voltage	V±%	220±%5	220±%5	220±%5	220±%5	220±%5	220±%5	220±%5
AC-voltage regulator	AUTOMATIC	C/I-regulator			COMPOUND-REGULATOR			ELECTRONIC
AUXILIARY ELECTRICITY		STANDARD			OPTIONAL			
1~/230 VAC	kVA	3,5	(3,5)	(3,5)	(3,5)	(3,5)	(3,5)	(3,5)
3~/400 VAC	kVA	NO	(5,0)	(9,0)	(9,0)	(9,0)	(9,0)	(9,0)
CONTROL VOLTAGE	V DC	12/24 V	24 V	24 V	24 V	24 V	24 V	24 V
DEMAGNETISATION	AUTOMATIC	PCI-CONTACTOR CONTROL 24 V DC						
HYDRAULIC CONNECTIONS								
Pressure line	P	BSP 1/2"	BSP 1/2"	BSP 1/2"	BSP 1/2"	BSP 3/4"	BSP 3/4"	BSP 3/4"
Return line	T	BSP 1/2"	BSP 1/2"	BSP 1/2"	BSP 1/2"	BSP 1"	BSP 1"	BSP1"
Serial connection	S	BSP 3/8"	BSP 3/8"	BSP 3/8"	BSP 3/8"	NO	NO	NO
HYDRAULIC REQUIREMENTS								
Minimal flow	l/min	18	32	46	55	68	95	123
Maximum flow	l/min	30	62	66	65	95	115	150
Pressure at nominal power	bar	190	190	190	190	190	190	190
Maksimum pressure	bar	250	250	250	250	250	250	250
Idle run pressure	bar	50	50	50	40	40	30	30
HYDRAULIC FLUID REQUIREMENTS								
Viscosity	cSt	10 - 200 / optimum 25 - 35						
Temperature	°C	max. 70 **						
Filter ratio, recommendation	um	min. 25						
OUTLINE DIMENSIONS								
Length	mm	420	475	485	540	790	790	1070
Width	mm	290	365	390	390	430	430	550
Height	mm	250	310	360	360	450	450	600
WEIGHT	kg	28	49	63	76	110	160	210

AC-GENERATOR'S TROUBLESHOOTING

<p>5. ABNORMAL NOISE LEVEL</p>	<p>5.1 Bearing failure.</p> <p>5.2 Generator is being overloaded.</p> <p>5.3 Short circuit in powered unit.</p> <p>5.4 Foreign items in generator's casing.</p> <p>5.5 Extremely fluctuating load.</p>	<p>5.1 Replace broken bearing.</p> <p>5.2 Reduce the load to proper level.</p> <p>5.3 Check powered unit. Rectify a defect.</p> <p>5.4 Stop generator and hydraulic system. Remove foreign item from unit.</p> <p>5.5 Can it be fixed ?</p>
---	--	---

<p>6. OIL LEAKAGES</p>	<p>6.1 Failure of axial sealing of generator's hydraulic motor. External indication—hydraulic oil outflow from ventilation grids.</p> <p>6.2 Oil leakage from hydraulic motor.</p>	<p>6.1 Axial sealing of hydraulic motor broken by reason of EXCESSIVE PRESSURE IN RETURN LINE. Rebuild the return line. Maximum allowed pressure in return line is 5 bar. Replace axial sealing of generator's motor.</p> <p>6.2 Hydraulic motor worn out and should be replaced.</p>
-----------------------------------	--	---

OUTLINE DIMENSIONS

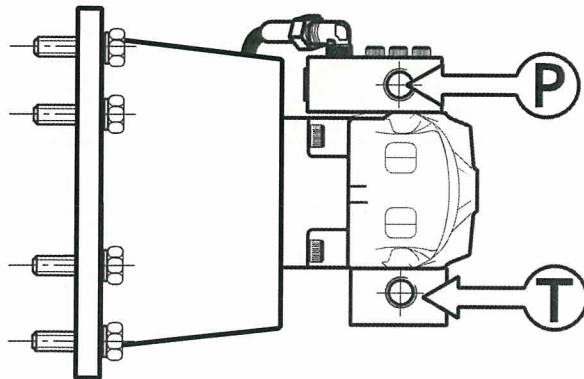
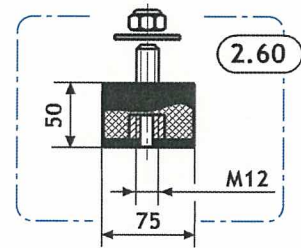
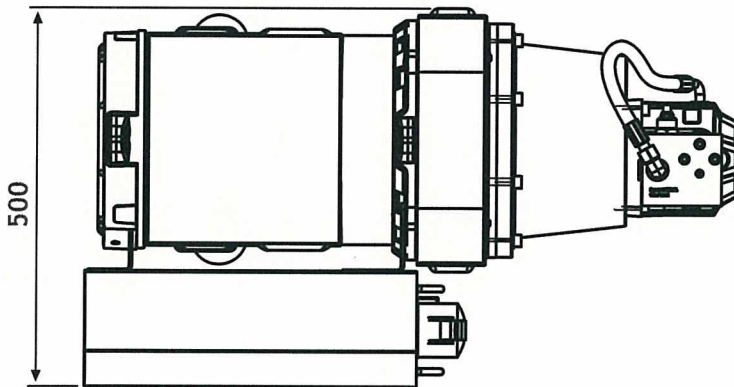
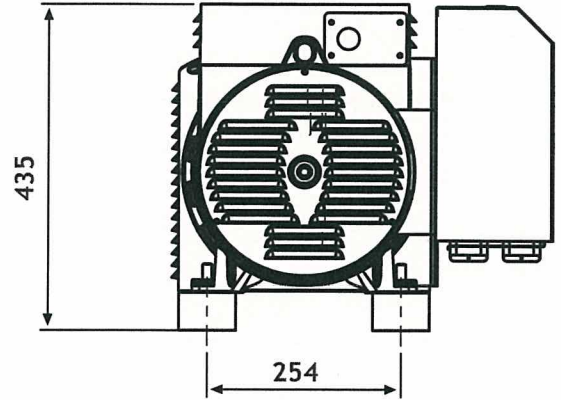
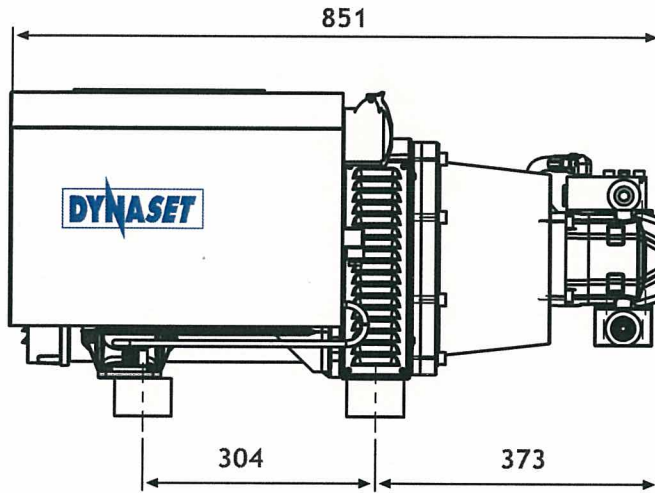

HYDRAULIC PORTS

PRESSURE
P

RETURN
T

BSP 3/4"

BSP 1"



SPARE PARTS

NOTE!
 WHEN ORDERING SPARE PARTS,
 UNITS TYPE, MODEL AND SERIAL
 NUMBER SHOULD BE INDICATED.

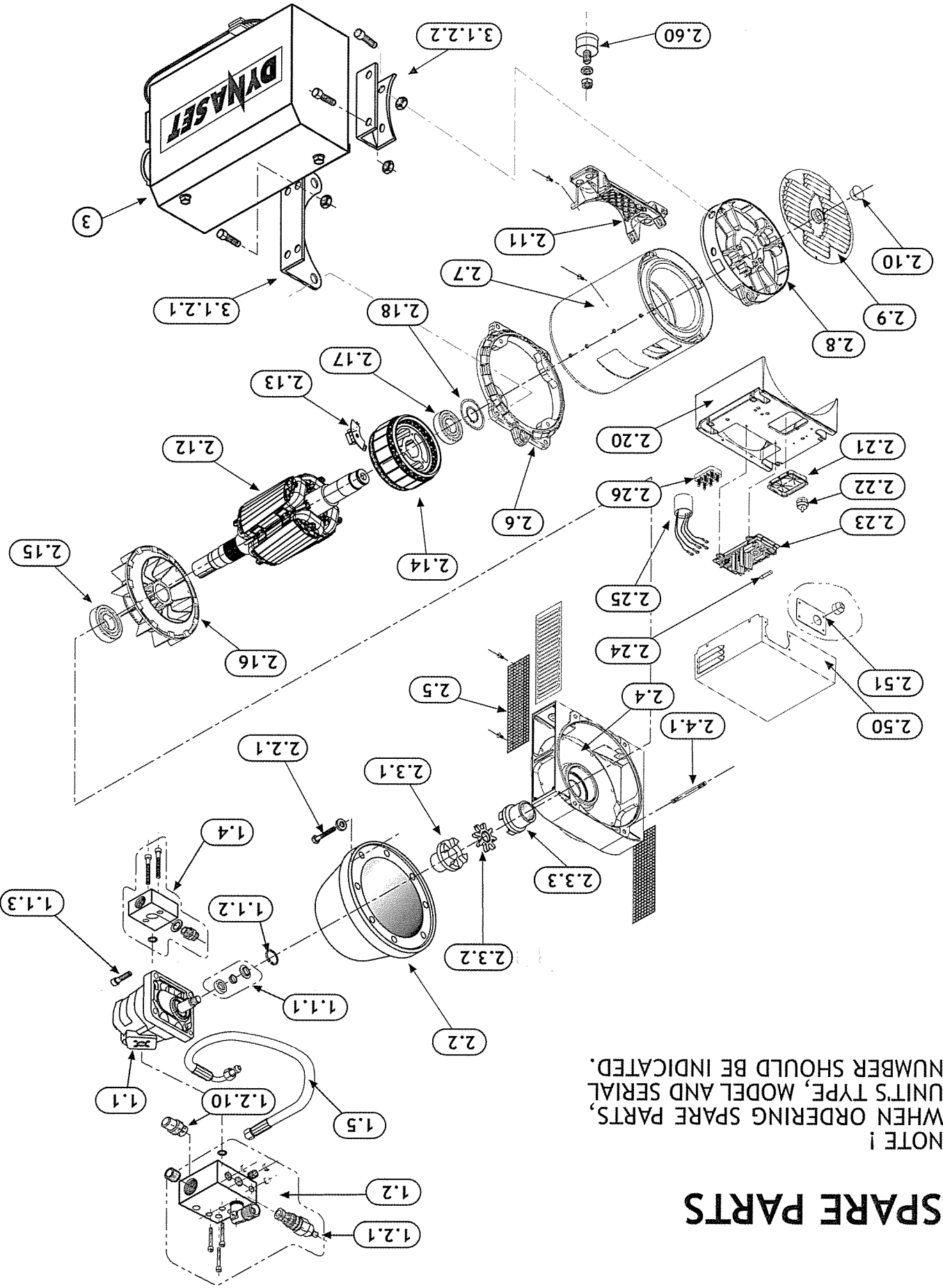

SPARE PARTS

No	PART NUMBER	DESIGNATION	DETAILS	QUANTITY
1		HYDRAULIC MOTOR ASSEMBLY		
1.1	007001519-43L	HYDRAULIC MOTOR	43	1
1.1.1	21048500	SHAFT SEAL, COMPLETE	24x40x7	1
1.1.2		LOCKING RING		1
1.1.3		ALLEN SCREW + WASHER	M10x35	4 + 4
1.2		RPM-VALVE BLOCK, COMPLETE		1
1.2.1		RPM-CARTRIDGE	0	1
1.2.2	07031799	VALVE BLOCK	10265L	1
		CHECK VALVE		1
1.2.3		FLOW SENSOR	5.7	1
1.4		RETURN LINE PORT, COMPLETE	1"	1
1.5	18034900	RETURN HOSE ASSEMBLY, COMPLETE		1
2	41048435	ALTERNATOR ASSEMBLY	HB4SBR	
2.2	9010095	MOTOR FLANGE	KP (3r-10,5)	1
2.2.1		ALLEN SCREW + WASHER	M10x40	8 + 8
2.3.1	81072170	HALF COUPLING, MOTOR SIDE	H110 / KP	1
2.3.2	81072260	RUBBER ELEMENT	H110x27	1
2.3.3	9010252	HALF COUPLING, ALTERNATOR SIDE	H110 / KP	1
	85006121	SET SCREW	M10x12	1
2.4	40610113-	FRONT MOUNT	H160	1
2.4.1	176009050	TIE ROD	M10 x50	4
		NUT NYLOCK + WASHER	M10	4 + 4
2.5	165002026	SIDE COVER	IP21 H160	2
		SIDE COVER	IP23	2
2.6	406101133	SPACER FLANGE	H 160	1
2.7	R577433--	STATOR ASSEMBLY	HB4CAR	1
2.8	406101213	REAR MOUNT	H160	1
2.9	165012008	AIR DIFFUSER	H160	1
2.10	266064018	CAP	DP 11	1
2.11	216008002	REAR SUPPORT	H160	1
2.12	537434---	ROTOR	HB4CAR	1
2.13	3008014	DIODE BRIDGE BOARD	HB4	1
2.14	507337045	EXCITER ROTOR		
2.15	1750016309	FRONT BEARING	6309-2RS1 C3	1
2.16	216002004	FAN		1
2.17	1750016308	REAR BEARING	6308-2RS1 C3	1
2.18	177003090	COMPENSATOR	D90	1
2.20	406108003	CHASSIS	H160	1
2.21	266060001	GLAND COLLAR		1
2.22	3057040006	INSULATOR TERMINAL	M6	1
2.23	3008013	ELECTRONIC VOLTAGE REGULATOR	AVR	1
2.24	30430202	FUSE	32x6.3 2A F	1
2.25	30010209	INTERFERENCE FILTER	/AVR	1
2.26	30600106	TERMINAL BOARD		1
2.50	165014019	COVER	H160 / -K	1
2.51	79180	PLATE WITH CABLE GLAND	K	1
	2690001021	CABLE GLAND	DG21 / -K	1
2.60	83075800	RUBBER CUSHION	70/50 M12	4
		NUT M12 + WASHER		4 + 4
2.60.1		GROUND WIRE	MAX. 30 CM	1 kit

AVR ELECTRIC CONNECTIONS

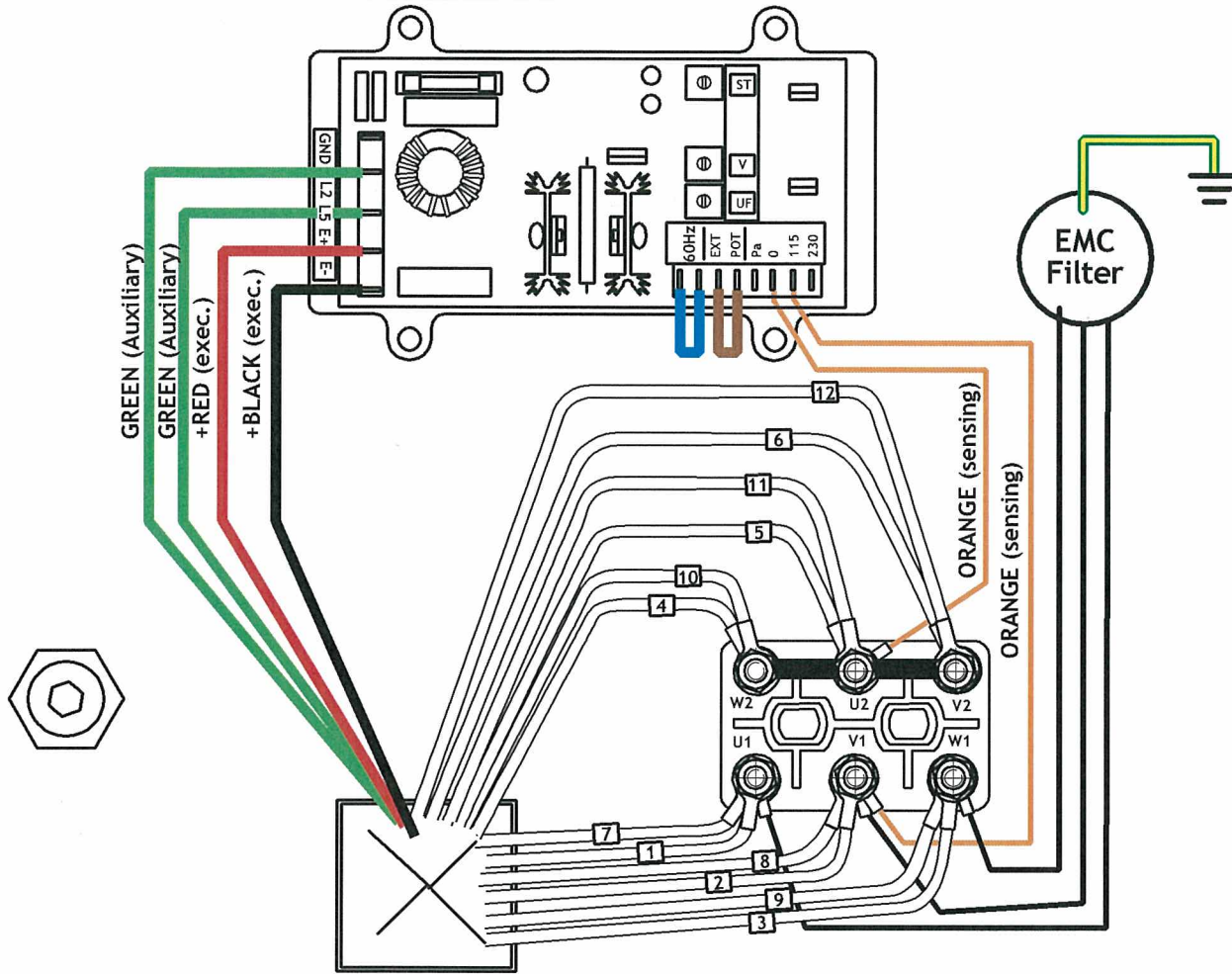

WIRING DIAGRAM

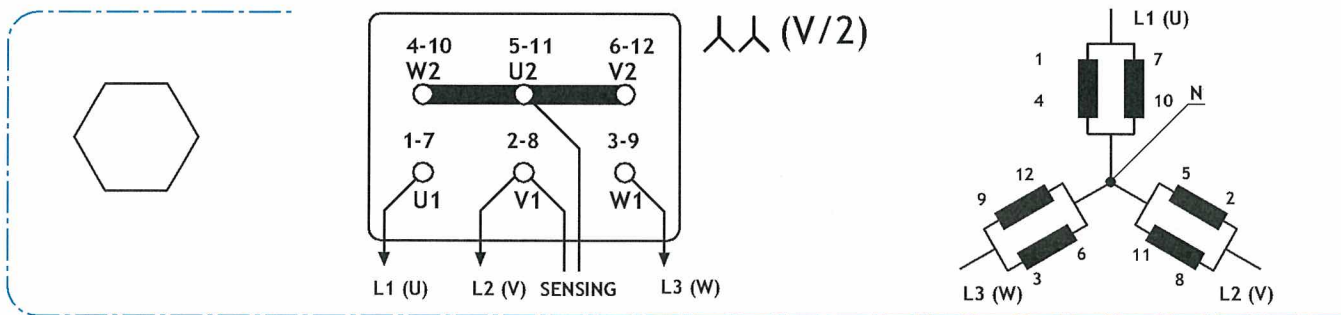

RESISTANCE CHARACTERISTICS				
STATOR	AUXILIARY	ROTOR	EXCITER STATOR	EXCITER ROTOR
Ω (ohm)				
0,50	5,30	15,70	13	4

CONTROL UNIT

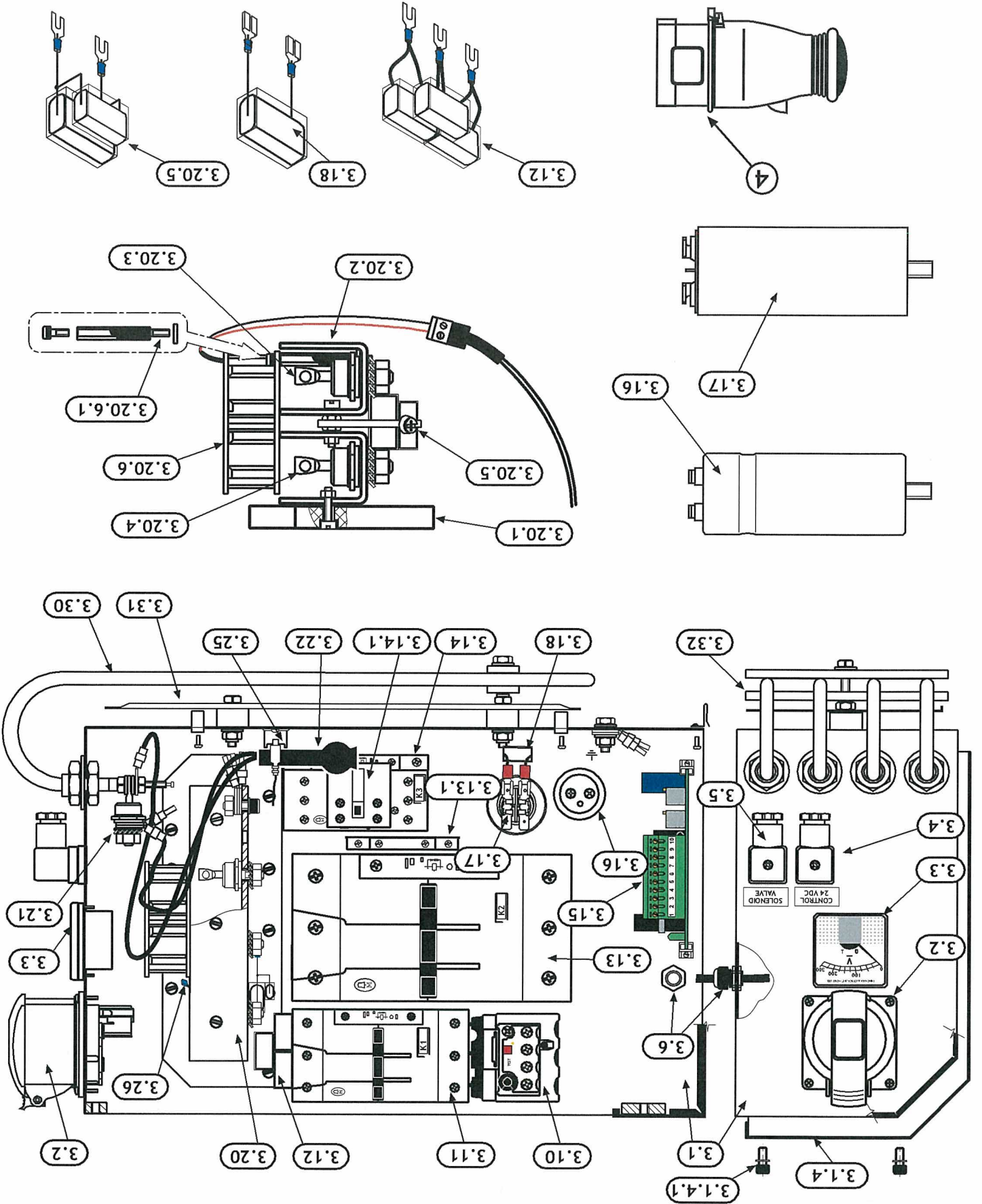

CONTROL UNIT

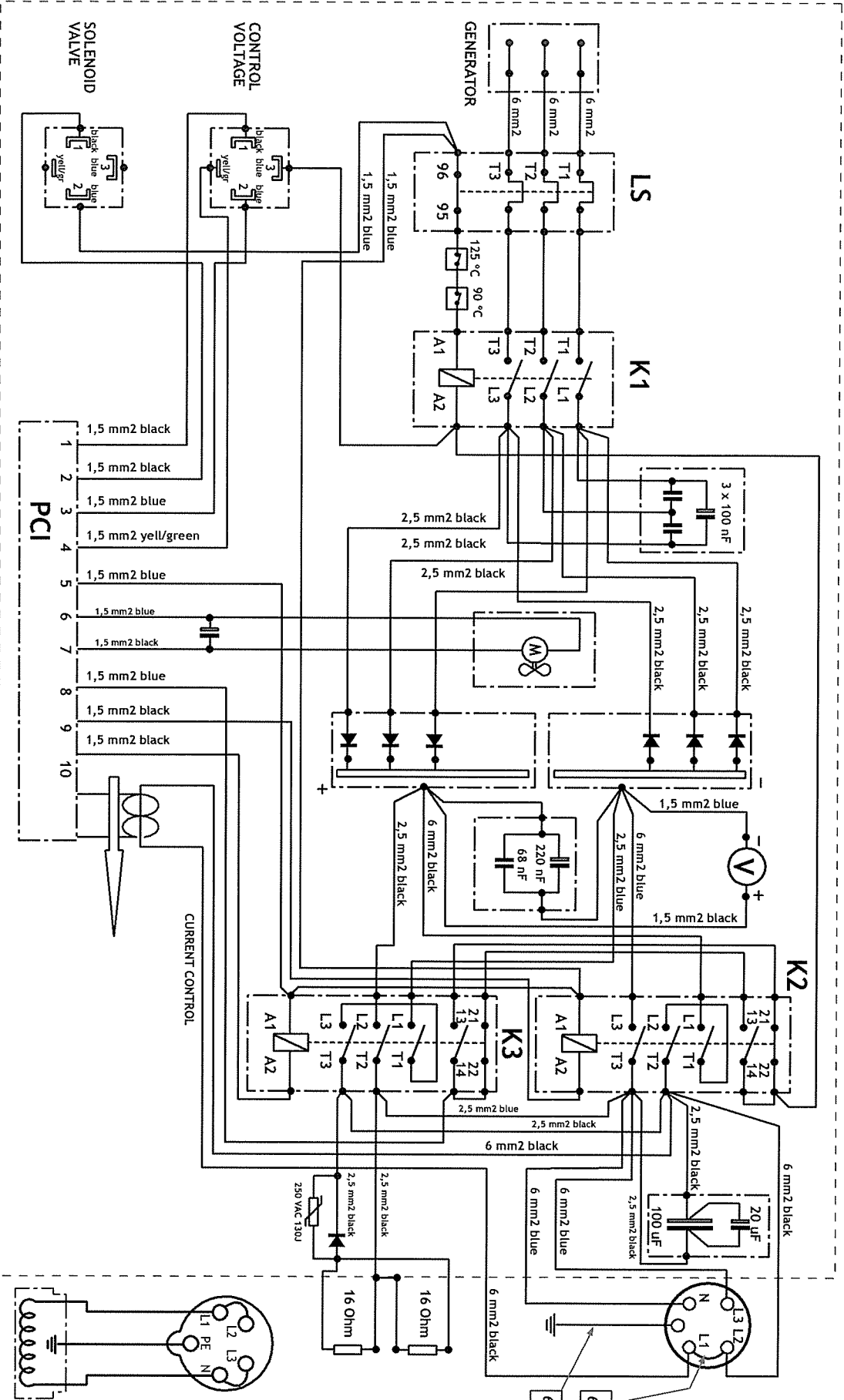

CONTROL UNIT

No	PART NUMBER	DESIGNATION	DETAILS	QUANTITY
3	9010310	CONTROL UNIT	15 kW	1
3.1		UNIT ENCLOSURE, COMPLETE	HMG 12-20	
3.1.1		COMPONENT CHASSIS, COMPLETE		1
3.1.2		GASKET		1
		ASSEMBLY KIT	HMG 15	1 kit
3.1.2.1	9010266	HOLDER, FORE	HMG 15-20	1
3.1.2.2	9010265	HOLDER, REAR	HMG 15-20	1
		FASTENERS		1 kit
3.1.4		COVER	HMG 12-20	1
3.1.4.1		ALLEN SCREW M6x10+WIDE WASHER + + GASKET		2+2+2
3.2	48058620	SOCKET 32A	3P+N+E	1
3.3	44051720	VOLTMETER	300 VDC	1
3.4	48059610	CONTROL VOLTAGE CONNECTOR, COMPLETE	Hirschmann	1
3.5	48059610	SOLENOID VALVE CONNECTOR, COMPLETE	Hirschmann	1
3.6		CABLE GROMMET		1
3.10	44051600	THERMAL OVERLOAD RELAY	Z1-57	1
3.11	4405143000	CONTACTOR	K1 (DIL M65)	1
3.12		CAPACITOR UNIT	100 nF x 3	1
3.13	4405146000	CONTACTOR	K2 (DIL M80)	1
3.13.1	44051490	AUXILIARY CONTACT	DIL NO/NC 10A	1
3.14	44051380	CONTACTOR	K3 (DIL M32)	1
3.14.1	44051490	AUXILIARY CONTACT	DIL NO/NC 10A	1
3.15	9010318	PCI-CONTROL CARD INSTALLATION KIT		1 1
3.16	4605803000	CAPACITOR	10000 uF 63 V	1
3.17	46057680	CAPACITOR	20 uF 450 V	1
3.18	46057580	CAPACITOR	100 nF	1
3.20		RECTIFIER UNIT		
3.20.1	03001414	CHASSIS PLATE	PE	1
3.20.2	03001079	RECTIFIER / COOLER BAR	AL	2
3.20.3	46056510	DIODE -70A UNF ¼	70 HFR 120	3
3.20.4	46056480	DIODE +70A UNF ¼	70 HF 120	3
3.20.5		CAPACITOR UNIT	220 nF + 68 nF	1
3.20.6	46058430	FAN	24 VDC	1
		FASTENERS		1 kit
3.21	46056600	DIODE + 85A UNF ¼	85 HF 120	1
3.22		DIODE PROTECTION VARISTOR	300 VAC (46056610)	1
3.25	44051620	TEMPERATURE SWITCH	90 °C	1
3.26	44051650	TEMPERATURE SWITCH	125 °C	1
3.30		HMG-RESISTOR R16	16 Ohm	2
3.31	03001880	HEAT REFLECTIVE SHIELD	HMG 12-20	1
3.32	03001317	RESISTOR HOLDER	HMG 6-20	2
		FASTENERS		1 kit
3.XX		WIRING KIT	NOT AVAILABLE	1 kit
4		PLUG 32A	3P+N+E	1